

## Table of Contents

<b>SAFETY</b> .....	<b>1</b>
1. SAFETY SIGN .....	1
1.1 Please confirm the reading and damage of the safety signs .....	1
1.2 Warning sign .....	1
1.3 Safety sign .....	2
1.4 Safety sign .....	3
2. PRECAUTIONS .....	9
2.1 About the Rules of the Operation .....	9
2.2 Appliances for ensuring safety .....	10
2.3 In case of abnormality and emergency .....	11
2.4 About operational hazards .....	11
2.5 Prevent fire .....	13
2.6 When getting on and off the machine .....	14
2.7 Prevent falling .....	14
2.8 Installation of fire extinguishers .....	15
2.9 Implementation of pre-operation check .....	15
3. ENSURE THE VIEW .....	16
3.1 Pay attention to the surrounding area .....	16
4. OPERATION PRECAUTIONS .....	17
4.1 Precautions during startup .....	17
4.2 Precautions when traveling .....	21
4.3 Precautions during the operation .....	22
4.4 Precautions when stopping the machine .....	27
5. ABOUT THE END OF THE OPERATION .....	29
6. PRECAUTIONS RELATED TO CHECK AND MAINTENANCE .....	29
6.1 Regular check .....	29
6.2 Before starting check and maintenance .....	30
6.3 Precautions when making checks and maintenance .....	30
6.4 Precautions for handling and use of grease and when painting .....	34
6.5 Precautions for welding .....	35
6.6 Precautions after completing check and maintenance .....	37
7. PRECAUTIONS RELATED TO THE BATTERY .....	37
7.1 Precautions when using batteries .....	37
8. USE OF ENERGY ACCUMULATORS WITH GAS SPRINGS .....	38
<b>RUNNING GEAR</b> .....	<b>39</b>
1. GENERAL ASSEMBLY DRAWING OF EXCAVATOR .....	39
2. GENERAL ASSEMBLY DRAWING OF CONTROL DEVICE AND INSTRUMENT .....	40
2.1 Overview of Electronic Monitor .....	41
2.2 Overview of Electronic Monitor .....	57
3. USE AT THE START AND END OF THE SEASON .....	79
3.1 Air conditioner operation and use .....	79
4. USE OF SEAT BELTS .....	81

4.1	How to fasten seat belts .....	81
4.2	How to unbuckle the seat belts .....	81
5.	USE OF DRIVER'S SEAT .....	81
5.1	Height adjustment .....	82
5.2	Seat back tilt adjustment .....	82
5.3	Seat fore and aft adjustment .....	82
5.4	Armrest adjustment .....	82
5.5	Headrest adjustment .....	82
6.	USE OF PARTS IN THE CAB .....	83
6.1	Unlocking and locking of cab's door .....	83
6.2	Driver's door lock .....	83
6.3	Opening the door from inside the cab .....	84
6.4	Opening and closing of the front window (upper) .....	84
6.5	Removal of front window (lower) .....	85
6.6	Interior lights .....	85
7.	EMERGENCY EXIT FROM THE CAB .....	86
8.	ADDITIONAL ACCESSORIES .....	87
8.1	Guard board, and side door (with lock) .....	87
9.	DESCRIPTION OF BLUETOOTH RADIO FUNCTION .....	88
9.1	Graphic panel .....	88
9.2	Introduction to panel button functions: .....	88
<b>OPERATION .....</b>		<b>91</b>
1.	DAILY MAINTENANCE CHECKS .....	91
1.1	Locking lever .....	91
2.	CHECK BEFORE STARTING THE ENGINE .....	92
2.1	Cooling water level check and refilling .....	92
2.2	Oil pan level check and refilling .....	92
2.3	Fuel level check and refilling .....	93
2.4	Fuel coarse filter drain .....	94
2.5	Checking the oil level in the working tank .....	94
2.6	Check of fan belt and air conditioner belt .....	95
2.7	Driver's seat adjustment .....	96
2.8	About the mirror adjustment .....	96
2.9	Display checking of multi-function displays .....	97
2.10	Confirmation of operation light illumination .....	97
2.11	Check the air filter intake .....	98
3.	ENGINE START .....	98
3.1	Start-up at room temperature .....	99
3.2	Cold start .....	99
3.3	Use the battery cable to start .....	100
4.	ENGINE WITH THE STOP .....	102
5.	ENGINE CHECK AFTER STARTUP .....	102
5.1	Lifting hydraulic locking lever .....	102
5.2	Action confirmation of engine and multi-function display .....	102

6.	WARM-UP .....	103
6.1	Engine warm-up .....	103
6.2	Warm-up of working oil .....	104
7.	AUTOMATIC IDLE STOP FUNCTION .....	104
7.1	Restart after automatic idle stop .....	105
8.	OPERATION MODE SELECTION .....	105
9.	SWITCHING OF WORKING DEVICE MODES .....	106
10.	OPERATION AND CONTROL OF THE MACHINE .....	106
10.1	Precautions for the operation and control of the machine .....	106
10.2	Traveling essentials .....	107
10.3	Switch for selecting between Speed 1 (low speed) and Speed 2 (high speed) .....	108
10.4	Driving in water and on soft ground .....	109
10.5	Essentials of getting off soft ground .....	109
10.6	Operation of rotatory and working devices .....	110
11.	ESSENTIALS FOR MACHINE OPERATION .....	112
11.1	Digging .....	112
11.2	Loading operation .....	113
12.	MACHINE PARKING .....	113
12.1	Park on a slope .....	114
13.	POST-OPERATION CHECKS AND CONFIRMATIONS .....	114
14.	USE UNDER SPECIAL CONDITIONS .....	114
14.1	Use in cold weather .....	114
14.2	Use in waterfront operations .....	115
14.3	Use in dusty sites .....	116
15.	PRECAUTIONS FOR LONG-TERM STORAGE .....	116
15.1	Wash the vehicle .....	116
15.2	Oil and grease filling .....	116
15.3	Battery .....	116
15.4	Cooling water .....	117
15.5	Dust and moisture resistant .....	117
15.6	Regular lubrication runs (in custody) .....	117
15.7	Use after long-term storage .....	117
	<b>CHECK AND MAINTENANCE .....</b>	<b>119</b>
1.	PERIODIC REPLACEMENT OF IMPORTANT SAFETY PARTS .....	119
2.	RECOMMENDED OIL VISCOSITY AND REPLACEMENT CAPACITY .....	120
5.	WEARABLE PARTS .....	121
6.	CHECK THE TIGHTENING TORQUE OF BOLT AND NUT .....	122
7.	TIGHTENING TORQUE FOR CONNECTORS AND HYDRAULIC HOSES .....	123
8.	CHECK AND MAINTENANCE CHECKLIST .....	126
9.	UNSCHEDULED MAINTENANCE .....	133
9.1	Check and replacement of wiper blades .....	133
9.2	Check of washer fluid .....	133
9.3	Replacement of bucket .....	134
9.4	Replacement of bucket teeth and side cutters .....	135

9.5	Check and adjustment of bucket wobble adjustment mechanism .....	137
9.6	Diesel system bleeding .....	138
10.	MAINTENANCE EVERY 8 HOURS (OR EVERY DAY) .....	139
10.1	Filling grease to the working device .....	139
10.2	Filling grease to the dozer blade .....	141
11.	MAINTENANCE EVERY 50 HOURS .....	141
11.1	Drainage of water and sediment from fuel tanks .....	141
11.2	Track tension adjustment .....	142
12.	EVERY 100 HOURS MAINTENANCE .....	144
12.1	Oil level check of traveling reducer .....	144
13	MAINTENANCE EVERY 250 HOURS (OR 3 MONTHS) .....	144
13.1	Adjustment of fan belt and air conditioner belt .....	144
13.2	Check of rubber hoses in the air intake system .....	146
13.3	Water tank hose crack and damage check .....	147
13.4	Check, cleaning and replacement of air filter elements .....	148
13.5	Water tank cap cleaning or replacement .....	150
13.6	Check and maintenance of batteries .....	151
13.7	Replacement of engine oil and engine oil filter .....	152
13.8	Oil-water separator replacement .....	154
13.9	Replacement of fuel filter .....	154
14	MAINTENANCE EVERY 500 HOURS (OR 6 MONTHS) .....	155
14.1	Replenish grease to the swivel bearing .....	155
14.2	Loose check of swivel bearing assembly bolts .....	156
14.3	Cleaning of fuel tank, protecting cover and filter mesh .....	157
14.4	Replenishment of grease in the push rod part of the operating lever .....	157
14.5	Check the amount of refrigerant of the air conditioner. ....	158
15.	MAINTENANCE EVERY 1000 HOURS (OR 12 MONTHS) .....	160
15.1	Ventilation valve filter element replacement .....	160
15.2	Replacement of rotary reducer oil .....	162
15.3	Replacement of oil of the traveling reducer .....	162
15.4	Filling grease to the rotary reducer .....	163
15.5	Inspection of rotary bearing lubrication grooves .....	163
15.6	Battery voltage check .....	164
16	MAINTENANCE EVERY 2,000 HOURS .....	165
16.1	Replace the oil return filter .....	165
16.2	Replacement of cooling water .....	167
16.3	Cleaning of pilot oil circuit filter .....	169
17	MAINTENANCE EVERY 5,000 HOURS .....	169
17.1	Replacement of working oil and washing of suction filter mesh .....	169
17.2	About maintenance of working machine in harsh environments .....	172
18	MAINTENANCE AND DESCRIPTION OF USE OF MACHINES WITH RUBBER TRACK PLATES ...	174
18.1	Description of rubber mat track plate and road liner .....	174
18.2	Warranty on rubber track plates and road liners .....	174
18.3	Use rubber track plates and road liners .....	174

<b>TRANSPORTATION .....</b>	<b>179</b>
1. TRANSPORTATION .....	179
1.1 Strictly adhere to road transportation laws .....	179
2. METHOD OF LOADING AND UNLOADING THE MACHINE .....	179
2.1 Loading .....	180
2.2 Fixing of the machine .....	182
2.3 Unloading .....	183
3. MAIN BODY LIFTING .....	184
3.1 Essentials for lifting .....	184
4. ASSEMBLY AND REMOVAL OF MIRRORS .....	185
5. TOWING .....	185
5.1 Method for towing this machine .....	185
<b>OPTIONAL PARTS .....</b>	<b>187</b>
1. ABOUT THE USE OF MACHINES EQUIPPED WITH BREAKER HAMMERS .....	187
1.1 Selection of breaker hammers .....	187
1.2 Installation of breaker hammers .....	187
1.3 Precautions during breaker hammer operation .....	187
2. REGULAR CHECK AND MAINTENANCE OF THE BREAKER HAMMER .....	190
2.1 List of regular check and maintenance of the breaker hammer .....	190
2.2 Strengthen of working device .....	190
3. ATTENTION POINTS PROPOSED BY BREAKER HAMMER MANUFACTURERS .....	190

# Safety

## 1. Safety sign

### A Warning Please read the instruction manual.

Please read the safety messages and indication in this instruction manual, and understand and follow them. Failure to follow this instruction manual and unintentional use of the machine may result in a serious injury, fatal accident, or severe damage to this machine.

### Safety messages

In order to inform operators of the dangers associated with "operation, check, and maintenance", safety signs are posted throughout the machine. This section records the contents related to the posting position of signs and hazards.

Please read the previous in instruction manual and all the signs posted on this machine and understand them!

### 1.1 Please confirm the reading and damage of the safety signs.

Please remove any dirt from the safety signs and replace them if any text is illegible or illustrations are not visible.

Use only a cloth, water, and soap to remove dirt from safety signs. Do not use solvents, gasoline, or other strong chemicals to remove dirt from safety signs. Solvents, gasoline, or other strong chemicals may weaken the adhesion of the safety sign and cause it to peel off.

- If the safety sign is damaged or lost, be sure to replace it with a new one. When the safety sign is installed on the part before replacement, please install the safety sign on the part after replacement. Sell new safety signs at our sales store of our company responsible for customers.
- Never remove any safety sign installed on this machine. Please deal with other labels in addition to the safety sign described on the following pages in the same way.

### 1.2 Warning sign

Please hang a warning sign in a conspicuous place such as the start button on the driver's seat to inform the outside world that the machine is in an operation prohibition state. Depending on the contents of the check and maintenance work, please hang a warning sign in places other than the driver's seat.



### 1.3 Safety sign

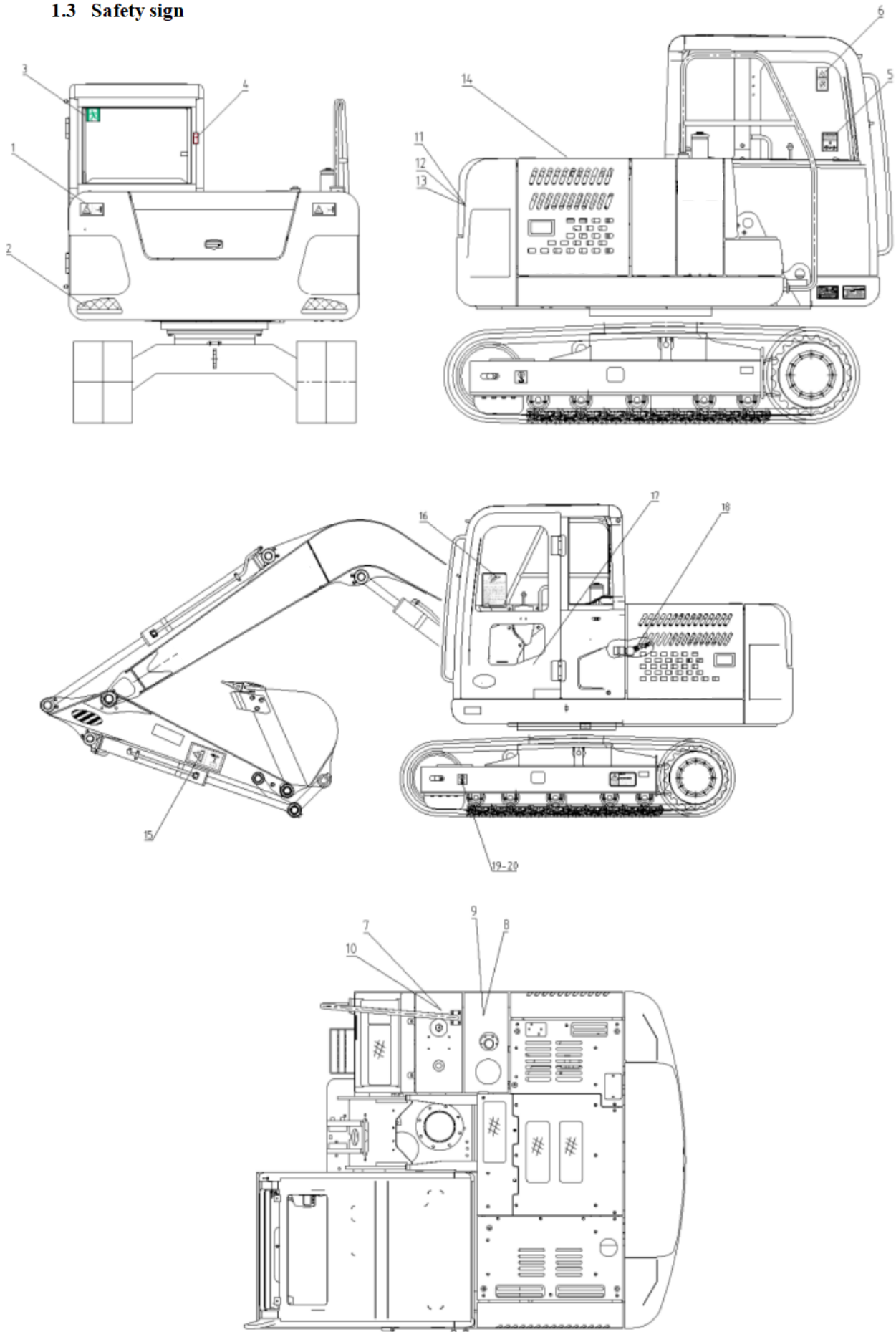

## 1.4 Safety sign

Pasting position: 1

Part number: 0790010011

- Keep away from rotation area of the machine. There is a risk of squeezing.



Pasting position: 2

Part number: 0790010003, 0790010004

- Counterweight warning sign



Pasting position: 3

Part number: 0790010013

- Safety exit



Pasting position: 4

Part number: 0790010020

- Fire extinguisher



Pasting position: 5

Part number: 0790010018A

- Operation sign



Pasting position: 6

Part number: 2290010007

- Warning on closing the front window



Pasting position: 7

Part number: 2290000009

- Fuel tank



Pasting position: 8

Part number: 0290010013

- Fuel tank



Pasting position: 9

Part number: 2290010032A

- Hydraulic oil tank

**HYD.OIL**

Pasting position: 10

Part number: 2290010031A

- Hydraulic oil tank

**DIESEL**

22-90-010031

Pasting position: 11

Part number: 2290010025

- Pay attention to the hot surface of the parts



This label indicates that the due attention shall be attached to the high temperature parts, preventing from the injury

Pasting position: 12

Part number: 2290010028

- Pay attention to parts fan which may hit your hands

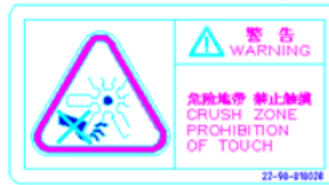

This label indicates that the due attention shall be paid to the fan that shall not be touched

Pasting position: 13

Part number: 2290010012

- Stop the rotation when testing and adjusting the machine



Pasting position: 14

Part number: 2290010014

- Beware of falling



Pasting position: 15

Part number: 2290010017

- 4 Pay attention to keep away from the machine in operation



Pasting position: 16

Part number: 2290010012

Reading precautions



Pasting position: 17

Part number: 2290010026

- Pay due attention to properly fastening the safety belts



This label reminds the driver of properly fastening the safety belt and safely operating the machine

Pasting position: 18  
Part number: 2290010025  
No touching the machine by hands



Pasting position: 19  
Part number: 2280000002  
Nameplate of the whole machine

Pasting position: 20  
Part number: 2290010013  
Lift the machine correctly



## 2. Precautions

### A **Warning Please read the instruction manual.**

Please read the safety messages and indication in this instruction manual, and understand and follow them. Failure to follow this instruction manual and unintentional use of the machine may result in a serious injury, fatal accident, or severe damage to this machine.

### 2.1 **About the Rules of the Operation**

#### **Follow basic safety rules**

Only people who have received training and have qualifications may run this machine.

When a license or other professional qualification is required to operate this machine in the country in which it is used, the driver must meet these conditions and hold a valid (which is not expired) license or other professional qualifications.

- During "operation, check, and maintenance" of this machine, please follow all safety-related precautions and steps described in this instruction manual.
- Please do not run when you are in poor health, taking medicine (drugs with hypnotic effects), having a smell of alcohol, or in an unstable state of mind.
- When the joint operation is made or there is a commander, fully negotiate about the operation contents and operate according to the specified gesture. The commander should give instructions from a place that is clearly visible to the driver.

#### **Ensure safety of the construction site**

Please understand your operation and the potential dangers.

- Please make risk assessment with the person in charge of the site prior to the operation and confirm that all necessary safety measures have been taken for the operation. Be sure to confirm with the person in charge of the site if there are any additional safety measures or safety rules for the operation.

Please learn about the working site. Before operating the machine, please make a visual inspection around the working site.

When operating the machine, please find the soil and other soft ground where the machine may sink or become unstable. Please place signs on soft road shoulders and foundations. There is a risk that the ground may be too soft when operating the machine on cliffs, ditches, or ground near the road shoulder. Rain, blasting operation, earthquakes, etc. may cause the loosening of the foundation. Please pay attention. Please assign the commander according to needs.

- Please select a place where there will be no landslide or falling rock or building debris will not fall onto the machine. · Please set the fence on the working site to prevent irrelevant people and/or machines from entering.
- During the operation on the side of the road, please assign a commander or place markers to notify vehicles and pedestrians of hazards and the possibility of falling objects.

#### **It is prohibited to access to the machine and working device in operation**

There is a risk of a fall accident. Do not make the following operations. During the operation, a person climbs onto the machine of the working device, upper rotating body, etc. • Do not stand on the lifted goods.

## 2.2 Appliances for ensuring safety

### Wearing of safety appliances

Please wear well-fitting clothes and safety appliances.

- Please wear clothes that will not expose your skin.
- Clothes with oil may catch fire, so change them.
- Fat clothes, decorations, long hair, etc. may hang on the operating lever or part of the machine, causing inadvertent movement of the machine or operating device.
- Wear helmets, safety shoes, safety glasses, protective masks, dust masks, safety vests, and other safety appliances suitable for the operation. Confirm appropriate safety appliances with the commander of the operation.
- Wear soundproof appliances when operating the machine in a place with noise.

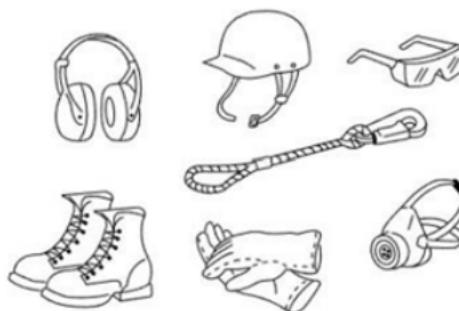

Prolonged exposure to noise can damage hearing or lead to hearing loss.

- Before using safety appliances, check whether there is any damage. If it is damaged or the service life has expired, please replace it.
- The commander and other related persons working in the vicinity of the machine shall wear safety appliances suitable for the operation. Confirm appropriate safety appliances with the commander of the operation.

### Prepare emergency supplies

In case of an emergency, please confirm the location of fire extinguishers (type: ABC, ABE) and first aid kits.

- Please learn how to use a fire extinguisher. Please follow the regulations to maintain the fire extinguishers.
- Please provide the means of reporting the emergency number, copy telephone numbers in advance, etc.
- Please check the first aid kit regularly and replenish the contents according to needs.



### 2.3 In case of abnormality and emergency

#### When an abnormality is detected

Stop the operation when abnormal sound, vibration, odor, instrument malfunction, smoke, oil leakage and alarm display on the alarm device or multiple displays of the machine are detected during the operation or check and maintenance.

- Please move the machine to a firm and level place, ground the working device, place the upper and lower cutoff locking levers in the locked position, stop the engine, and remove the key.
- Please contact with the person in charge of the operation.
- Please entrust the repair to the sales store of our company.

#### Emergency exit from the cab

An escape hammer is provided for emergency escape from the cab. In the event of an emergency, please stop the engine, remove the escape hammer to break the glass of the cab, and escape from the cab.



#### In case of fire or other emergency

- Please stop the engine.
- Please exit the machine through the armrest and steps.

#### In the event of a thunderstorm

- Ground the working device. If possible, allow the working device on the front end to sink into the earth.
- Before a thunderstorm occurs, please get out of the cab and leave the machine. Or stop the machine, turn off the radio, and stay in the closed cab until the thunderstorm passes.

### 2.4 About operational hazards

#### Pay attention to falling objects and flyovers

Prior to operation, please confirm that a cab guard board that complies with the working site is installed. For the cab guard board, please contact with the sales store of our company.

- During dismantling operation of buildings where there may be falling objects and flyovers or operation on the construction site (including mines or quarries), Be sure to use the front guard board (lower and upper) and top guard board.
- During hydraulic crushing, dismantling, or cutting operations, install a front guard board even if there will be no falling object or flyover above the cab.
- During the operation in which there may be falling



objects or flyovers, evacuate people other than the operator out of the reach of falling objects and flyovers.

- During the operation, be sure to close the front window and door before running.

### Ensure the safe foundation

During the operation on road shoulders and at the edge of cliffs, the machine tends to lose its balance, which is very dangerous. For easy reversing, keep the tracks vertical to the road shoulder and place the traveling motor (1) at the rear. In particular, for platforms made of earth and rocks, the road shoulders tend to collapse when the rain has just stopped. Please confirm the condition under your feet. In addition, do not dig the surrounding area of the machine excessively.

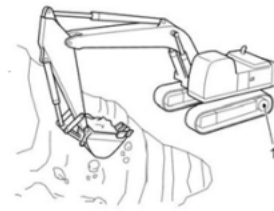

### Mind the wires

- Do not get close to high voltage wires. Electric shock can lead to serious personal injury and death.
- Please confirm the voltage of the wires on the construction site with the power company in advance.
- To prevent an electric shock accident, please assign a commander and ask him/her to make gestures to prevent the machine from getting close to the wires.
- The operator shall not leave the driver's seat while the machine is in contact with an electric wire.

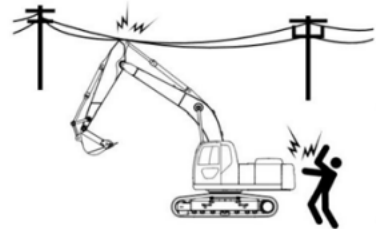

### Safe distance from the high voltage wire (standard)

Voltage	Target value for isolation distance of the electric power company
100V.200V or lower	2m or higher
6.600V or lower	2m or higher
22,000V or lower	3m or higher
66,000V or lower	4m or higher
154,000V or lower	5m or higher
275,000 V or lower	7m or higher
500,000V or lower	11m or higher

### Use of working lights

- During the operation in a dark place, please turn on the working lights and set lighting facilities according to needs to provide sufficient brightness in the surrounding area.
- Discontinue operation if your vision is deteriorated by fog, rain, or especially thunder or snow.

### **Operation on the soft ground**

During the operation on soft foundation or wet ground, the machine may get stuck in the mud and it is difficult for it to get out. Please lay columns, wood, etc. horizontally to prevent the machine from sinking. In addition, frozen foundations will gradually soften as the temperature rises.

### **Pay attention to loose foundations**

Foundations may be loose near cliffs, road shoulders, and deep ditches. Before running or operation, please confirm that they are not loose. The machine may tip over or fall due to the weight of the machine and vibration that causes the collapse of the foundation. Please note that foundations collapse easily, especially when the rain has just stopped, after blasting, and after an earthquake.

## **2.5 Prevent fire**

### **Fires caused by kindling**

Fuel, engine oil, battery liquid, window washer fluid, etc. may catch fire when they are near a combustion source. Please strictly follow the following matters:

- Please remove when combustible materials such as withered leaves, saw dust, and scraps of paper accumulated in or attached to the engine's exhaust manifold, muffler, battery accessories, and lower cover plate.
- Please do not smoke or use fire in the vicinity.
- Stop the engine before replenishing fuel.
- Do not leave the machine when replenishing fuel and engine oil.
- Do not spill fuel on overheated surfaces and electrical system parts. Please wipe spilled fuel and grease immediately.
- After filling oil, please tighten the caps for fuel and engine oil.
- Please keep the fuel and engine oil in the specified place and avoid the approach of irrelevant personnel.
- During grinding or welding operation of the machine, please move the kindling to a safe place.
- Do not weld iron or hard pipes containing flammable solutions or cut them by gas cutting.
- Please use flame retardant oil as cleaning oil for parts, etc. Do not use diesel fuel, gasoline, or other items that may ignite a fire.

### **Fire of electrical circuit**

A short circuit in the electrical system can lead to a fire accident.

- Keep all electrical circuit junctions clean and securely fix.
- Check whether wiring is loose or damaged, retighten loose connectors and wiring clamps, and repair or replace damaged wiring.

### **Fire of wiring**

Please confirm that hose and hard pipe clamps, guard boards, and buffer devices are securely fastened. If they are loose, during the operation, they will rub with other parts because of vibration, hose and others may be damaged, and high pressure oil may spray, which may cause fire and fatal

accident.

Please check. If there is any abnormality, retighten, repair or replace quickly. Do not use bent or damaged piping or hoses.

### **Explosions caused by lighting appliances**

Use explosion-proof lighting appliances for inspection and maintenance. Explosion-proof lighting appliances must have specifications that do not cause fires or explosions even in places where flammable gases and dusts are concentrated.

## **2.6 When getting on and off the machine**

### **Precautions when getting on and off the machine**

There is a danger of falling. Please note the following:

- When grease, dirt, ice, garbage, or other things that tend to slip are attached to the treads and armrests, remove them.
- Please check the appearance and assembly part of the treads and armrests, replace damaged parts, and retighten loose bolts and nuts.
- When getting on and off the machine, be sure to use the treads and armrests.
- Please face the machine and use the 3 parts of the armrests and treads to keep your body balanced.
- Do not grab the operating lever and lifting hydraulic locking lever to get on or off the machine. · Do not get on or off the machine with parts, tools, etc. in your hands.
- Do not jump down from the machine or get on or off the running machine.

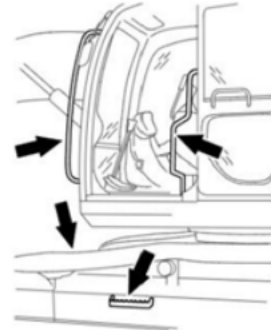

## **2.7 Prevent falling**

### **Beware of falling**

- Use appropriate appliances and protective appliances for fall prevention. During the operation that involves a risk of falling, use appropriate appliances that can respond to the potential risk.
- Use an aerial working platform, scaffolding and ladders. When necessary, use an auxiliary crane.
- During the operation off the ground and without aids, drivers and assemblers must wear certified fall prevention appliances.
- All fall prevention appliances must comply with the rules of the country, region and territory where the machinery is installed.
- Do not use personal protective appliances that are poor or damaged. Before starting work, assign some protective appliances for replacement.
- When grease, working oil, ice, garbage, or other substances that tend to slip are attached to the treads, armrests, tracks, ladders, and scaffolding, remove them.
- Make spot check of the appearance and installation part of treads, armrests, ladders, and



scaffolding. Replace damaged parts, and tighten bolts and nuts that have become loose.

- Wear safety belts and other protective appliances according to the operation content.
- There is a risk of falling when operating at heights. Watch your step.
- Use treads, armrests, tracks, ladders, and scaffolding when moving at heights.
- When getting on or off the machine, please face the machine and use the armrests and treads to keep your body balanced.
- Do not grab the upper and lower cutoff locking lever or operating lever to get on or off the machine.
- Do not get on or off the machine with parts, tools, etc. in your hands.
- Do not jump down from the machine or get on or off the running machine.
- After the operation, wipe the spilled grease and return tool items to the place for keeping items.

## 2.8 Installation of fire extinguishers

Fire extinguishers shall be installed to respond to emergencies or fires.

Please make sure that the fire extinguisher is properly installed on the fire extinguisher bracket (1) on the left side in the cab.

In the vicinity of the fire extinguisher bracket (1), a sign indicating the location where the fire extinguisher is installed (2) is affixed.

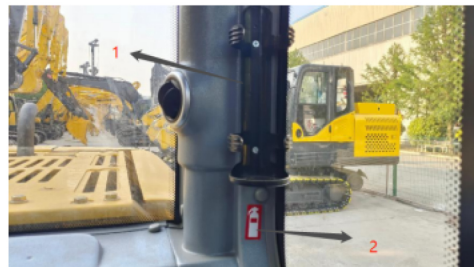

## 2.9 Implementation of pre-operation check

You must make the pre-operation check. If any abnormality is found, it should be repaired before operation.

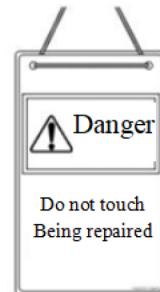

### Warning sign display

Non-related personnel should not start the engine or touch the operating lever during check and maintenance.

Before check and maintenance, be sure to ground the working device, place the upper and lower cutoff locking lever in the locked position, stop the engine, and remove the key.

Please hang a warning sign in a conspicuous place such as the start button on the driver's seat to inform the outside world that the machine is in an operation prohibition state. Depending on the contents of the check and maintenance work, please hang a warning sign in places other than the driver's seat.

### Confirmation of the maintenance log

Read the maintenance log to ensure that regular maintenance and necessary repairs have been completed.

### **Please always keep the machine clean**

Spilled oil, lubricating oil or scattered debris all have a hazard. Please always keep the machine clean and tidy.

If water enters the electrical system, it may cause poor operation or short circuit, thus leading to failure and fire. Do not wash various sensors, connectors or inside of the cab with water or steam.

In addition, do not wash the ventilation holes of cover, protective cover, and others with a high pressure.



### **Precautions in the cab**

- Remove dirt and oil from the soles of your shoes before entering the cab. Operation of the treads with dirt or oil on them may cause slipping and result in an accident.
- Do not leave parts or tools around the cab. To prevent fires, please pay attention to the following points.
- It is strictly prohibited to bring dangerous goods such as flammable and explosive substances into the cab.
- Do not leave lighters in the cab. It may cause an explosion when the room temperature rises.
- Always extinguish your cigarette after smoking.
- Do not leave plastic bottles in the cab or attach suction cups to the window glass. Plastic bottles and suction cups may act as lenses, thus resulting in a fire.

### **Seat belt check**

Before fastening the seat belt, please confirm whether the belt is worn and the metal parts used for connection are damaged. If there is a problem with the seat belt or metal parts, replace them before using the machine.

Please replace the seat belt every 3 years. If it is broken, please replace it at any time.

## **3 Ensure the view**

### **Warning Please read the instruction manual.**

Please read the safety messages and indication in this instruction manual, and understand and follow them. Failure to follow this instruction manual and unintentional use of the machine may result in a serious injury, fatal accident, or severe damage to this machine.

#### **3.1 Pay attention to the surrounding area**

If you are driving or operating in a place with poor view, you will not be able to confirm the condition of operators and obstacles in the vicinity of the machine, which may lead to serious fatal accidents or damage to the machine, so please strictly follow the following points.

- Please wipe the windows clean.
- Please replace the cracked glass.
- Be sure to adjust the mirror to ensure a good view around the machine before operation. In addition, please remove any dirt from the mirror.
- For machines equipped with rearview and side cameras, ensure that the lenses are free of dirt to maintain clear images in the rear and on the side on the display.

- When the working device covers the view on the right side while driving, remove the working device to ensure the view.
- Mirrors and cameras have dead corners. Before driving, make the safety inspection around the machine.
- When visibility cannot be adequately ensured, configure the commander according to requirements. Please have only one commander signal.
- During the operation in a dark place, please turn on the working lights and set lighting facilities according to needs to provide sufficient brightness in the surrounding area before the operation.
- Discontinue operation if your vision is deteriorated by fog, rain, or especially thunder or snow.
- Please do not install mirrors and others on armrests. Inadvertent installation can reduce the strength of the fixing part of the armrest due to excessive vibration and there is a risk of damage or falling off.
- Do not operate in the state of the display without displaying the rearview and side cameras.
- Do not disassemble and decompose rearview and side cameras.

The camera system is installed on the machine body according to ISO16001:2017. Since decomposition and disassembly may make the warranty invalid, please contact with sales store of our company when disassembly and decomposition are required.

#### **Lens and camera position**

Please use only Pure Mirrors and rearview and side camera systems.

## **4. Operation precautions**

### **A Warning Please read the instruction manual.**

Please read the safety messages and indication in this instruction manual, and understand and follow them. Failure to follow this instruction manual and unintentional use of the machine may result in a serious injury, fatal accident, or severe damage to this machine.

#### **4.1 Precautions during startup**

##### **Confirm warning signs**

Before starting the engine, please confirm whether there is the identification of the warning sign. Do not start the engine when the warning sign is put up.

Warning signs are used to release the notice that the machine is in a no-operation state.

Please report the condition to the manager of the machine. Do not use the engine to start until the warning sign is removed.



### **People other than the driver are prohibited from riding the vehicle**

The operation of the driver's seat must be implemented by one person. Not person can enter the cab or climb up onto the machine.

### Confirm the safety of the surrounding area before operation

Please note the following matters when starting the engine and before operating the machine:

- There is no one around, above or below the machine.
- There is no other machine or obstacle around the machine.
- Please set the fence on the working site to prevent irrelevant people and/or machines from entering.

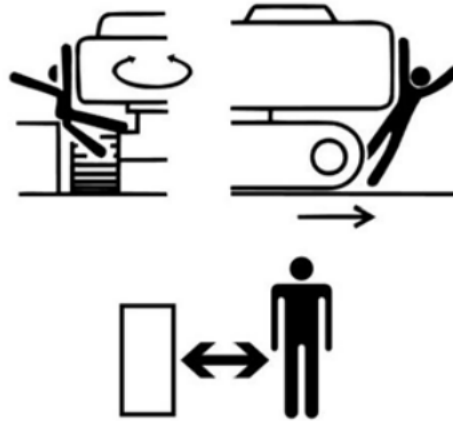

### Confirm the safety before operation

Please confirm the following matters before operation:

- Please close the doors and window, and lock.
- Please close the check window and doors, and then lock.
- The mirror should be located in a place where you can see the surrounding area from the driver's seat.

### Fasten the seat belt

- To prevent fatal accident or death, be sure to fasten the seat belt during the operation.
- Please sit in the driver's seat and adjust the seat position so that you can operate the operating levers, treads and switches properly.



### Precautions before starting the engine

- Place the lifting locking lever (1) in the "locked position".

If it is not placed in the "locked position", the machine may move against the driver's intention if the operating lever is touched by accident.

- Please place all levers in the neutral position.
- Before starting the engine, please sound the horn to give a warning.

A: Locked position B: Release position

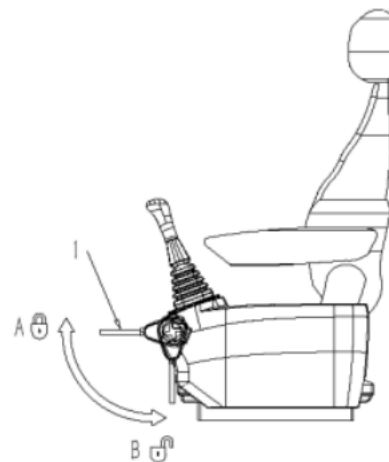

Do not connect the battery directly to the starter for starting. The machine may move by accident, causing fatal accidents or damage to the electrical system.

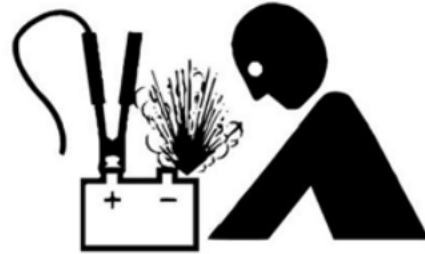

### **Perform warm-up operation**

If the working device is started without sufficient warm-up, the working device will react slowly to the operating lever and may sometimes move beyond the driver's intention, which may cause an accident. Be sure to perform the warm-up operation. Especially when the weather is cold, please perform sufficient warm-up operation.

### **Pay attention to the mode switching of the working device**

Please confirm that the working device used and the working device mode are consistent. If the wrong working device mode is selected, it cannot move properly, and it may also lead to a fatal accident or damage to the machine.

### **Confirm the operating mode**

Be sure to confirm the movement of the operating lever and the tread before operation.

If the operation mode on the selected identification nameplate is not consistent with the machine's movement, please stop the operation and disconnect the machine's power supply. The movement of the machine must be consistent with the operating mode.

If the movement of the machine is different from the nameplate identified in the cab, please replace with the nameplate with consistent operation mode. If there is any abnormality, do not run the machine until the abnormality is removed. Please contact the sales store of our company for more information.

### **Confirm the warning device**

If it is equipped with a horn, driving warning, rotating flashing lights and other warning devices, please confirm that they are working properly.

### **Pay attention to bucket interference**

Depending on the combination of the type of working device and the specifications of the optional parts on the side of the body, the working device may interfere with the cab and other parts of the machine during the operation.

Please confirm whether there is no interference before operation.



### Precautions when rotating and traveling

- Be sure to sound the horn to warn people around the machine before starting the engine, before making the machine travel, or before rotating the upper rotating body.
- Be sure to ensure a safe distance from other machines or obstacles in the vicinity, and then run.
- In the area with poor view, please assign a commander.



## 4.2 Precautions when traveling

### Pay attention to the direction of the machine

Before starting the machine, please confirm the position of the front guide wheel (1). The position of running forward is the state in which the front guide wheel (1) is in front and the chain wheel (2) is at the rear.

If the lower running body (track) becomes reversed, it moves in the same direction as the operation of the operating lever. Please operate the traveling lever slowly and walk at a low speed.

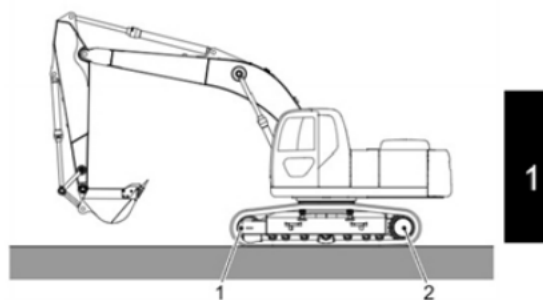

### Please operate the traveling operating lever slowly.

- Do not perform the violent handle operation such as an emergency start.
- Do not operate the lever violently when switching from forward to reverse (or switching from reverse to forward).
- Do not turn or reverse violently in place.
- Do not perform violent handle operations (let-go operation) such as switching from maximum velocity to emergency stop.

### Precautions when traveling

Please choose a flat and firm foundation to travel on if possible.

- Please move the working device according to needs to confirm the view on the right side of the machine while running.
- When traveling on unlevelled ground surface, please travel at a low speed.
- Do not cross obstacles. When you have to cross, keep the working device in a position close to the ground and run at a low speed. Otherwise, it may tip over.

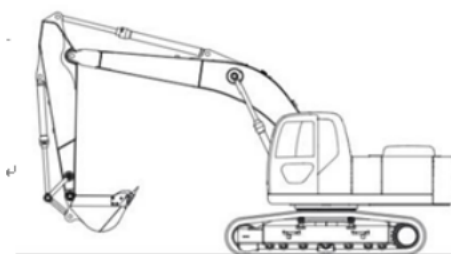

### About running when climbing and going down a slope

Do not drive on a slope of 30° and above. Otherwise, it may result in tipping.

- Please climb and go down a slope at a low speed.
- When climbing a slope, please extend

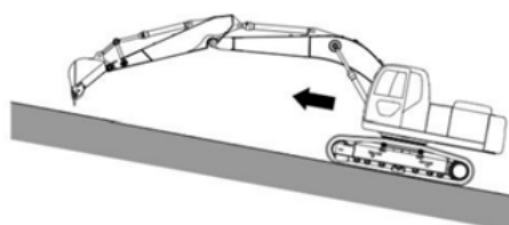

the front working device forward during running to avoid backward tipping.

- When going down a slope, make sure that you can immediately lower the bucket and stop while running.
- The machine may slip easily on grass, fallen leaves, ice, iron plates, etc. when running. Please be careful.

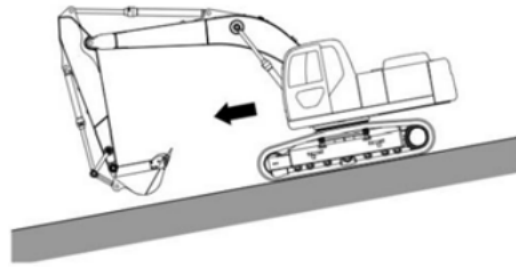

#### **Precautions for traveling on the slope**

When traveling on the slope, watch out for tipping and side-slipping.

Be sure to keep away from the slope, run along flat places, and enter the slope at the destination. Do not cross the slope.

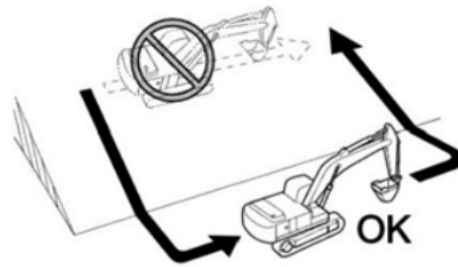

#### **Precautions for running on frozen ground and snow**

Be very careful when operating the machine on frozen ground and snow.

- The floor is very slippery and the machine may slip.
- Emergency start, emergency stop, and emergency rotation may cause instability and tipping over of the machine.
- If you cannot see the road shoulder or snow drift due to snow, please be very careful during the operation.
- You may not be able to see the setup when it is buried in snow. Please be very careful during the operation. The foundations that are in a frozen state will become soft as the temperature rises. Please pay attention.

#### **4.3 Precautions during the operation**

Be sure to follow the steps in this instruction manual for machine operation. Abuse and misuse may result in injuries, fatal accidents, damage to items, and shortened durability of the machine. Do not have the following behaviors regardless of the situation.

#### **It is prohibited to use the rotation force for operation**

Do not use the rotation force for moving away rocks, crushing sidewalls, and other operations.

Excessive force applied to the machine when operating with rotation force will cause damage to the working device and shorten the service life of the rotation device.



**It is prohibited to use the traveling force for operation**

Do not place the bucket against the ground and use the traveling force directly for digging or flattening operations.

Excessive force applied to the machine when operating with traveling force may cause damage to the working device and machine.

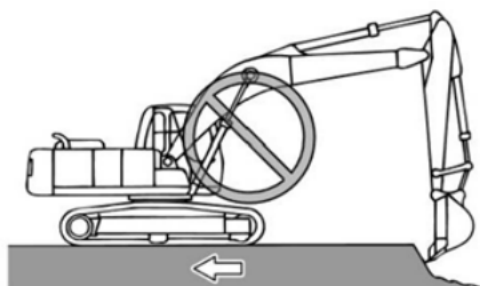

**It is prohibited to use the bucket's falling force for operation**

Do not use the bucket as a picking and digging tool or use the bucket for pile driving. Otherwise, excessive loads will be applied to all parts of the machine.



**It is prohibited to use the falling force of the body for operation**

Do not use the machine's falling force for digging. Significant damage may be caused to the machine and parts.

If you use other methods to dig after cutting hard rocks into small pieces, it will not damage the machine and it is economical.

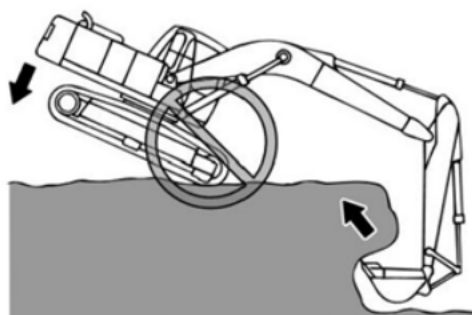

**Precautions during the operation on the slope**

Operation on the slope can make the machine unbalanced and may result in tipping. When you have to operate on a slope, please be careful of the following points.

- Please keep the tracks parallel to the slope.
- When the bucket is loaded with gravel, rotate it to the bottom of the trench at a low speed.
- On the slope, even if the rotation operation is stopped, it sometimes rotates under the action of its own weight. Please pay due attention during the operation.
- If stopping on a slope, the bucket shall touch the downhill side before digging into the ground.

**Confirmation before the digging operation**

- During operation in places where there may be gas, tap water, telephone, electricity, and other piping, consult with the competent authority or public service company about these places before operation.
- Always note whether there is any buried object and contact with the competent

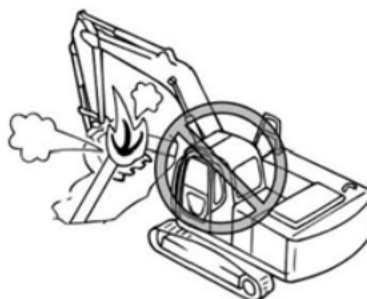

authority or a unit other than the public service company as required.

#### **Avoid colliding with this machine**

During operation below tunnels, overpasses, or power lines, inside buildings, and in other places where height is limited, pay sufficient attention so as not to collide with the working device. If the machine or working device contacts with an obstacle, it may result in a fatal accident or damage to the machine.

To prevent fatal accident and damage to the machine, keep the machine body and working device at a safe distance from obstacles.

Please assign a commander to ensure that their instructions can be followed.



#### **Operation below cliffs or extended positions**

Digging holes below cliffs is dangerous. Do not do it. Otherwise, it may result in falling rock.

The cab guard board protects the driver to a limited extent. It cannot prevent serious injury or fatal accidents in all cases.

The cab guard board is designed according to ISO 10262 and must ensure that no falling objects that would penetrate the cab can pass through.



#### **Precautions for deep digging operation**

Please note the following matters to prevent operating the machine while digging deeply or diagonally.

- Prevent small arm or hydraulic piping from contacting with slots and holes.
- Please note that it may interfere with the tracks when lowering the boom to its lowest position due to oblique digging.

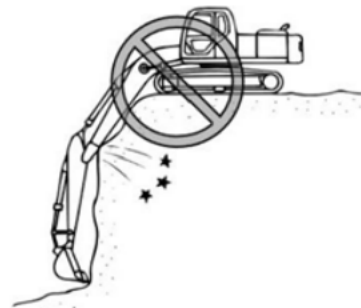

#### **Pay attention to bulldozing plate interference**

When placing the bulldozing plate in the front for operation, the boom cylinder and bucket may interfere with the bulldozing plate. Please pay full attention.



**Pay attention to contraction of the front part**

Contract the front part while traveling or transporting. Not let the bucket collide with the bulldozing plate.



**Pay attention to bulldozing plate collisions**

Do not allow the bulldozing plate to collide with rocks, causing early damage to the bulldozing plate and oil cylinder.



**Pay attention to unbalance loading of bulldozing plate**

When supporting the vehicle body with the bulldozing plate, the bottom of the bulldozing plate shall contact with the ground in a balanced manner to avoid concentrated loads or partial loads on the bulldozing plate.

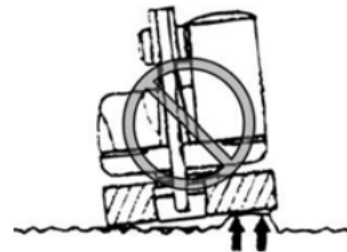

**Lifting and moving of personnel are prohibited**

Never use the working device for operations of lifting or moving of personnel. Otherwise, the personnel may fall, resulting in a major accident.



**It is prohibited to use the end of the small arm cylinder stroke to lift the vehicle body**

Lifting the vehicle body with the end of the small arm cylinder stroke may even cause damage to the working device, oil cylinder, etc. Do not do it.

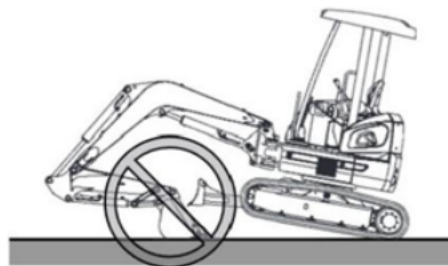

**Personnel shall not be underneath the bucket**

Do not allow the bucket or working device to pass over a person's head.

When the bucket and working device pass over the operator's head or over the driver's seat of the dump truck, contact of falling gravel with the bucket may cause fatal accidents and damage to the machine.



**Pay attention to soil dropping of the bucket**

Do not drop soil through hitting by holding the bucket, as this may cause damage to the work equipment and oil cylinder.

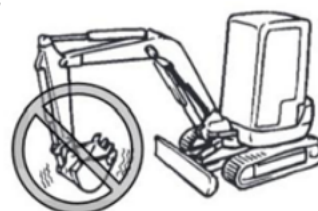

**Lifting operation**

This machine is designed for digging, loading and leveling operations with a bucket.

In addition, depending on the machine, the operation of installing a hydraulic hammer or a crusher is considered in the design.

When lifting items with this machine, please follow the regulations of your country or region.

Do not lift items such as the teeth of a bucket, hydraulic hammer or crusher, even if the lifting operation can be performed according to the regulations of your country or region.

Falling off of slings and other item falling can lead to major disasters or fatalities.



**It is prohibited to operate with the end of the oil cylinder stroke**

Keep some margin (A) at the end of the cylinder stroke during the operation. If it is used at the end of the stroke, there will be excessive load, which will damage the oil cylinder, pin, boom, small arm, etc.

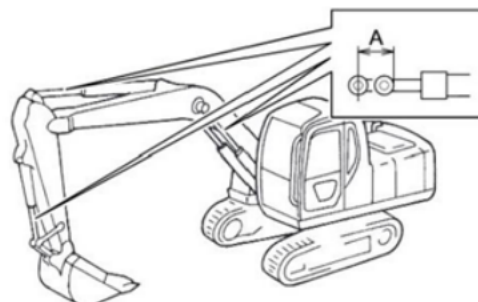

**It is prohibited to operate in confined spaces**

Do not use the machine in a confined place or a place where proper ventilation is not possible.

**Pay attention to potentially explosive environments**

When it is used in environments where there is a potential for explosion, follow national and local regulations.

**Precautions when leaving the driver's seat**

Do not leave the machine directly with the engine running.

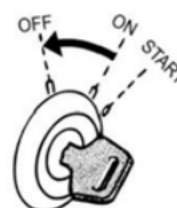

**4.4 Precautions when stopping the machine**

If the machine is not stopped properly, it may have unexpected movement due to sliding or the next time it is started. Please follow the correct parking procedure when stopping the machine.

**Machine Parking**

1. Move the machine to a level and firm place.

2. Please let the bucket touch the ground.

If a dozer blade is installed, allow the dozer blade to touch the ground.

3. Be sure to set the automatic throttle switch to "OFF".



4. Be sure to place the lifting locking lever (1) in the "locked position (A)".

If it is not placed in the locked position, the machine may move against the driver's intent when the lever is touched, which is very dangerous.

5. Please turn the throttle adjustment knob to the low idle position.

6. Please place the start switch in the OFF position, turn off the engine, and remove the key.

When leaving the machine, please close the windows, driver's door, all doors and cover plates, and then lock them.

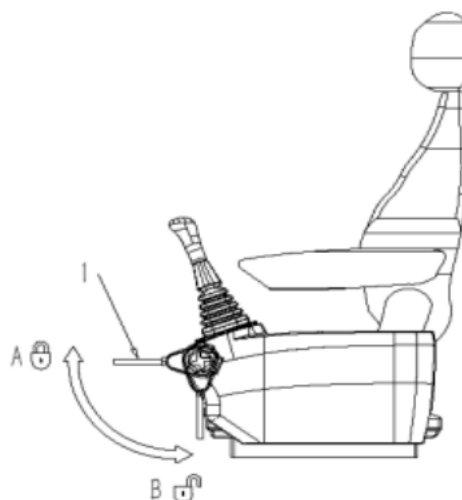

### Park on a slope

When you have to stop on a slope, follow the following steps.

1. Please ensure that the front of the machine body faces the downhill side.

2. Please hold the bucket against the ground.

If a dozer blade is installed, allow the dozer blade to touch the ground.

3. Be sure to set the automatic throttle switch to "OFF".

4. Be sure to place the lifting locking lever (1) in the "locked position (A)".

If it is not placed in the locked position, the machine may move against the driver's intent when the lever is touched, which is very dangerous.

5. Please turn the throttle adjustment knob to the low idle position.

6. Please place the start switch in the OFF position, turn off the engine, and remove the key.

When leaving the machine, please close the windows, driver's door, all doors and cover plates, and lock them.

7. To prevent the machine from moving, block the tracks with a blocking object.

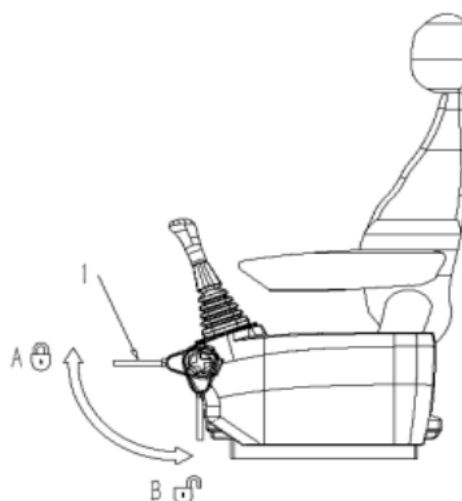
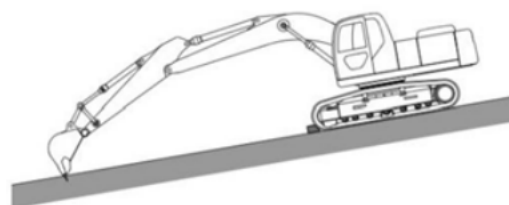

## 5. About the end of the operation

### A Warning Please read the instruction manual.

Please read the safety messages and indication in this instruction manual, and understand and follow them. Failure to follow this instruction manual and unintentional use of the machine may result in a serious injury, fatal accident, or severe damage to this machine.

To use this machine immediately on the following working sites, please prepare in advance.

1. Move the machine to a level and firm place.
2. Please let the bucket touch the ground.

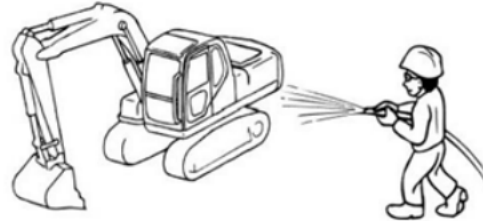

3. Be sure to place the lifting locking lever (1) in the "Locked Position (A)" to confirm that all operating levers and treads return to the neutral position.

4. Please close the windows to prevent water and moisture from damaging the electronic parts of the machine.

5. Please close the windows, cab's door, all doors and cover plates, and lock them.

6. Please fill the fuel tank.

It can reduce air and water droplets, and alleviate problems such as frozen fuel tank and moisture-induced rusting.

7. Please sweep the machine for check. When a problem is detected, perform appropriate disposal such as oil filling, repair, or replacement before restarting the machine. And please contact the sales store of our company as needed.

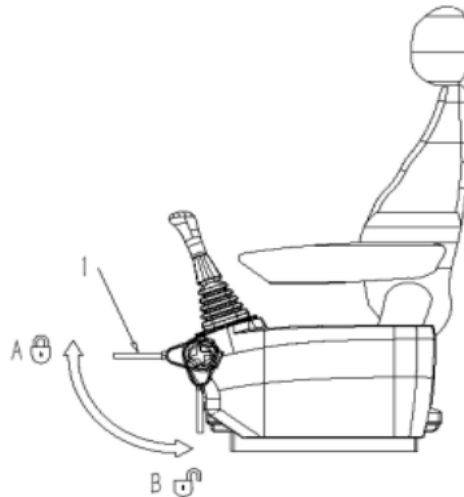

8. When the machine is stored in a cold area, please remove the battery from the machine and store it in a warm and well-ventilated place. This can prevent early aging of the battery.

## 6. Precautions related to check and maintenance

### A Warning Please read the instruction manual.

Please read the safety messages and indication in this instruction manual, and understand and follow them. Failure to follow this instruction manual and unintentional use of the machine may result in a serious injury, fatal accident, or severe damage to this machine.

#### 6.1 Regular check

Please make regular independent checks once a year. Please consult with sales store of our

company for independent check as needed.

Please make regular independent checks once a month.

When making these checks, please keep records according to applicable statutes, ordinances and regulations.

## **6.2 Before starting check and maintenance**

### **Read the operation and maintenance methods carefully**

Before check and maintenance, please read the instruction manual thoroughly, understand the maintenance methods (preparation for safe operation, tools, qualifications, important parts, decisions of the operation commander, wearing of protective appliances, etc.), and pay attention to safety during check and maintenance. Incorrect maintenance not only leads to damage to the machine, but also may lead to fatal accident in maintenance.

### **Negotiate about contents of the operation**

In order to prevent accidents caused by a lack of understanding of the contents and steps of the operation, please negotiate about the contents of the operation thoroughly in advance.

#### **Assignment of commander**

Please assign the commander according to needs. Drivers should always follow the hand signals of the commander.

### **Organizing, tidying up and sweeping of the construction site**

Please remove any obstacles on the construction site. Remove grease, engine oil, paint and debris types. Organize, tidy up and sweep for safe operations. When making checks and maintenance, if the construction site is messy, it may tip over or cause injuries due to debris.

### **Warning sign**

- Prevent irrelevant personnel from starting the engine or touching the operating lever during check and maintenance.
- Before maintenance, be sure to allow the working device to touch the ground, place the lifting cutoff locking lever in the locked position, stop the engine, and remove the starting key.
- To give notice that the machine is in a no-operation state, hang a warning sign in an easily recognizable place such as the start key of the driver's seat. Please hang a warning sign outside the driver's seat according to the check and maintenance operations.
- When you have to make a check with the engine running, a person shall sit in the driver's seat, be prepared to stop the engine at any time, and cooperate with each other in the operation.



If a problem is found, be sure to contact the sales store of our company before restarting the machine.

### **Use of appropriate tools**

Please use the right tools managed properly. The use of damaged tools or tools that are not suitable for the purpose for which they are used may result in a fatal accident.

## **6.3 Precautions when making checks and maintenance**

### **Check and maintenance are made after the engine is stopped**

Before check and maintenance, stop the engine and cool the engine and other parts. Do not

touch engine parts while the engine is rotating or just after the engine has stopped. Rotating parts, high voltages, high-pressure liquid, high temperatures, and other risk factors can lead to major disasters.

### Pay attention to high-temperature liquid

Otherwise, skin scald may occur.

- To prevent burn caused by spraying of hot water or steam, please confirm that the tank lid is cool enough to touch with hands when checking or draining the cooling water. Please slowly loosen the protecting cover to release the pressure inside the water tank, and then remove the protecting cover.
- To prevent hot engine oil (hydraulic oil, oil) from spraying out and coming into contact with hot parts and causing burn, please confirm that the protecting cover and plug are cool enough to be touched with hands when checking and draining the engine oil. Please slowly loosen the protecting cover and plug to release the internal pressure, and then remove the protecting cover and plug.



### Pay attention to high-pressure oil

There is always internal pressure in the hydraulic circuit. Do not fill or drain oil or make check or maintenance during the application of internal pressure.

- Even after a long time after the engine stops, sometimes there is still residual pressure in the hydraulic circuit. Before replenishing and draining the working oil, and checking and maintaining the machine, be sure to press the venting valve on the working tank and release the pressure in the hydraulic piping by slowly loosening the connection between corresponding hose and connector.

High-pressure oil leaking from a very small hole can be dangerous when it is exposed to the skin and eyes.

- Be sure to wear a protective mask, safety glasses, and gloves when checking the leakage.
- Please block the leakage area with thick paper or board, and then check it.

In the event of contact with high-pressure oil or if high-pressure oil penetrates skin of human body, receive immediate diagnosis from a professional doctor.



### Use of high-pressure hoses and piping

If engine oil or fuel leaks from piping, it may cause fire and malfunction of the machine.

If you find that a piping assembly is loose, or engine oil or fuel is leaking from the assembly part, stop operation and retighten it with the specified torque. In addition, if you find damage or deformation of hoses or piping, consult the sales store of our company. The hose needs to be replaced when the following conditions are found.

- Hose damage and head deformation
- Scratches or breaking of the covered part, and exposed wire reinforcement layer
- Localized swelling of the covered part
- Some hoses may have signs of kinking and flattening

### Pay attention to the electric shock

Only skilled electrical-related personnel or trained operators shall check and maintain electrical equipment under the supervision of the electrical technician according to the electrical code.

When checking or maintaining an energized machine, be sure to assign other operators next to the emergency stop or main switch and the over-voltage protection device. If you need any assistance, please contact the sales store of our company.

### Pay attention to the rotating part

Keep away from rotating and movable parts.

- Getting caught in a rotating part such as a fan and belt may result in serious injury. Do not run the machine without the guard board installed in the specified place.
- Do not drop or insert objects or tools into the fan, belt, etc. Otherwise, items and tools will fly out, or fans or belts will be broken.
- When you have to make a check with the engine running, a person shall sit in the driver's seat, be prepared to stop the engine at any time, and cooperate with each other in the operation.



### Pay attention to the ventilation

Check and maintenance indoor or in poorly ventilated premises may result in gas poisoning. When handling engine exhaust, fuel oil, cleaning oil, or paint, especially make sure that the ventilation is adequate.

When maintaining and operating indoors, proper ventilation is required. Please set ventilation fans as needed.



### Precautions when disassembling and storing working devices

For possible tipping and falling, please note the following matters:

- Disassemble the working device according to the operation commander's instructions and steps in this instruction manual.
- When storing the removed working device,



store it in a stable state to prevent it from collapsing.

### **Precautions when operating below the machine and working device**

If you have to go below the lifted machine or working device for check or maintenance operation, support the machine or working device properly.

- Before maintenance or repair below the machine, please stop the machine in a level and firm place so that the working device touches the ground. Lift the lifting cutoff locking lever and remove the key.
- Please use support blocks to effectively block the tracks.
- If you need to operate under the lifted machine, be sure to use a square bar,

jacking seat, or other firm and stable members to support the machine. Never go below a machine or working device when it is not effectively supported.

In particular, during maintenance on the oil cylinder, implement it.



### **Locking of access door**

When the machine is maintained, be sure to secure the support bar at the spot check window with the door open. Otherwise, it may cause injuries due to shaking of the spot check windows and doors.

### **Do not drop tools and parts**

Dropped objects may cause breaking and malfunction of the machine, which may lead to accidents.

- Retrieve the tool immediately when you drop it.
- Secure the parts properly and store the tools properly after maintenance.

### **Precautions when adjusting track tension**

The grease cylinder is under the high pressure. If the grease fitting is loosened sharply, the grease fitting may fly out.

- Please wear appropriate protective appliances.
- Keep your face, hands, feet, etc. away from the direction of the assembly of the grease fitting. When grease adheres to the skin, it may cause inflammation. Therefore, wash well with water and soap.



- When releasing the grease fitting, release it slowly for 1 round or less. If no grease flows out even after the grease fitting is released for 1 round, consult the sales store of our company.
- Refer to "Track Plate Tension Adjustment" for details on adjusting the track plate tension after releasing the grease pressure.

**It is prohibited to disassemble the kick spring of the track adjuster**

Never disassemble the kick spring assembly.

The kick spring assembly contains a powerful spring. Therefore, if inadvertent disassembly is performed, the spring may fly out and cause a major fatal accident. If you need to disassemble it, please entrust it to the sales store of our company.

Precautions during knocking operation

During the knocking operation, pins flying out and metal pieces flying apart may result in serious fatal accidents. Please strictly follow the following matters:

- When striking firm metal parts such as pins, bucket teeth and bearings, flying debris may cause major fatal accidents. Please wear protective appliances such as goggles, gloves, helmets and safety shoes.
- When striking pins, bucket teeth, etc., fragments and other things may fly off and injure those around them. Please confirm that there no one is nearby before operation.
- When striking out pins, bucket teeth, bearings, etc., use a liner to avoid direct striking.

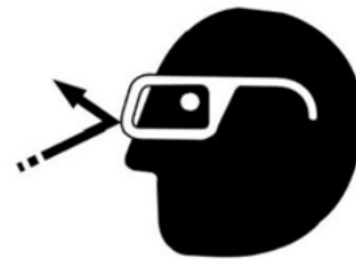

**Pay attention to the refrigerant in the air conditioner**

- If liquid from the air conditioner refrigerant splashes in your eyes or comes into contact with your hands, it may cause blindness or frostbite. Therefore, do not release the parts of the refrigerant circuit.
- Inhaling refrigerant gas from air conditioner can be fatal to the human body.
- Never place a source of ignition near the refrigerant gas of the air conditioner.

When disposing of hazardous materials such as refrigerants, follow applicable statutes, ordinances and regulations.

Please contact the sales store of our company if you need more help with suitable disposal method of refrigerant.

The refrigerant gas compressed by the compressor has a high temperature. Do not touch the compressor, hoses, or condenser directly with your hands until the refrigerant gas temperature drops.

**6.4 Precautions for handling and use of grease and when painting**

**Handling and use of grease**

- Discharging hot grease and other liquid may pose a risk of burns. Discharge grease until the machine has cooled down.
- Be sure to wear goggles, face masks, long sleeves, and gloves to prevent skin exposure,

which can cause serious illnesses including burns and inflammation.

- Do not drink grease. It can cause diarrhea-vomiting or severe illness and even death.
- Please label containers for grease and dispose of them according to state regulations.
- Please store grease out of the reach of children.
- If grease, butter, and other substances enter the eyes, please flush with water and have them examined by a doctor quickly.

#### **Precautions when painting**

- Vapors from paint are inflammable and may explode. Keep all items that can be a source of ignition away from paints and other materials that have ignition properties.
- When painting, please ventilate the construction area frequently. Reduce the possibility of exposure of the exhaust system during painting operation and when drying after painting. If the ventilation is not sufficient, install other ventilation devices such as fans and exhaust extension tubes as necessary.
- When using paint, your skin shall not be exposed to the paint. Use personal protective appliances such as masks with air filters or air-supply masks, goggles, protective gloves, bandanas, long sleeves, pants, and shoes with closed toes from beginning to end.
- If paint enters your eyes, please wash with plenty of water and consult a doctor quickly.
- If nausea is caused by inhaling vapors or toxic gases, rest in a place with clean air and get medical attention if necessary.
- Use a carbon dioxide fire extinguisher or foam fire extinguisher in case of fire.
- Please wash the paint with soap if it gets on your skin. Be examined by a doctor if you have symptoms of pain or inflammation.
- Please spread wood chips or absorbent around the spilled paint to prevent it from spreading. Remove the paint by sucking it up with a rag.

Wipes used to remove spilled paint can spontaneously combust and catch fire if they are not disposed of properly. Wipes used to soak up and remove paint shall be immediately placed in an airtight metal container filled with water.

- Wash your hands and face after painting operations, and rinse your mouth before having a meal.
- Store paint in airtight containers out of the reach of children.
- Paints, solvents shall be disposed of as industrial waste according to the corresponding rules.

#### **6.5 Precautions for welding**

**Never use objects with high temperatures in the vicinity of hydraulic machines, pipelines, or hoses.**

Do not heat pipes and hoses containing high-pressure oil during welding or soldering operation or when using a welding gun. Otherwise, flammable vapors and spray may be generated, which may catch fire.



Be sure to protect hydraulic machine, piping, hoses and other combustibles with fireproof blankets.

Please make sure that a suitable fire extinguisher is readily available.

**Do not heat piping containing flammable oil.**

- Do not weld iron or hard pipes containing flammable oil or cut them by gas cutting.
- During welding and gas cutting, rinse off flammable oil with a non-flammable solvent.



**It is prohibited to modify the machine**

- When modifying the machine, please consult the sales store of our company in advance.
- Damage or malfunction of the machine caused by modification without consent of our company is not covered by the warranty.

**Precautions during repairing welding**

Before welding operation on the machine, please contact our company as soon as possible. Otherwise, wires, electronic processors, hoses, and rubber tubes may be damaged due to welding operation. Only the manufacturing company or sales store of our company can weld the components (lower traveling body, upper frame, device parts, etc.) . If anyone else welds, the customer's warranty on the machine will be void.

Do not weld tank or piping containing flammable liquid or substance. Empty the piping and tank and remove the contents. Flush piping and tank with non-flammable solvent before welding or gas cutting.

To prevent serious injury or fire, during welding operation, please use equipment suitable for the operation with a welding device and it must be performed by qualified welding operation personnel.

**Basic precautions during welding and grinding operations**

- Please pack combustibles and prepare a fire extinguisher as a precaution.
- Please operate in a well-ventilated place.
- Be sure to wear protective appliances suitable for welding.
- Please stop the engine and remove the key.
- Please remove the negative (-) terminal of the battery and disconnect the power supply. If it is equipped with a battery power disconnect switch, set the switch to "OFF".
- Please protect the container in the surrounding area.
- Connect a ground wire on the same base material near the welded part (within 1 m).

Connecting a ground wire near electronic components and connectors can cause failure of electronic equipment.

- Do not allow seals, bearings, etc. to enter the space between the welded part and the ground wire.
- Do not ground the periphery of the pin or oil cylinder of the working device. Otherwise, damage to the plating of the pin and oil cylinder may be caused.
- To prevent the generation of gas, please peel off the paint from the welded part.
- After welding or grinding operations, please confirm that there is no smoke or dust in the surrounding area.

## **6.6 Precautions after completing check and maintenance**

### **Precautions after maintenance**

Before operating the machine, please confirm that the operating device is functioning properly.

- After maintenance, please run the engine at low idle speed to confirm that there is no oil or water leakage in the maintenance area.
- Slowly operate each operating lever to confirm the movement.
- Then, please increase the engine speed and operate each operating lever to confirm that there is no oil or water leakage or other abnormalities.
- Please close the guard board, engine hood, doors, etc.

### **Disposal of waste liquid, etc.**

- Use a container without leakage for the used waste liquid.
- Never let it drip on the ground, or be discharged into sewers, rivers, pools, or the ocean.

To protect the environment, please entrust the waste to a professional manufacturer for disposal.

- When disposing of fuel oil, oil, cooling water, urea water, brake fluid, solvents, filters, batteries, or other hazardous materials, please comply with applicable statutes and regulations.



## **7. Precautions related to the battery**

### **Please read the instruction manual.**

Please read the safety messages and indication in this instruction manual, and understand and follow them. Failure to follow this instruction manual and unintentional use of the machine may result in a serious injury, fatal accident, or severe damage to this machine.

### **7.1 Precautions when using batteries**

#### **Prevent burns caused by battery liquid**

Wear goggles, long-sleeved clothes, and rubber gloves when using the battery.

The battery liquid contains dilute sulfuric acid. If the battery liquid adheres to the eyes and skin, it will potentially cause blindness and burns. If it adheres, rinse immediately with plenty of water and seek immediate medical attention.



### Prevent battery explosions

- Hydrogen is generated inside the battery and there is a danger of explosion. Please keep away from combustion source, cigarettes, etc.
- Please tighten the battery cap.



### Disposal of batteries

Do not dispose of the battery alone. Please entrust a specialized manufacturer for recycling and disposal.

## 8 Use of energy accumulators with gas springs

### A Warning Please read the instruction manual.

Please read the safety messages and indication in this instruction manual, and understand and follow them. Failure to follow this instruction manual and unintentional use of the machine may result in a serious injury, fatal accident, or severe damage to this machine.

High-pressure nitrogen is sealed in energy accumulators and gas springs, and rupture can cause serious fatal accidents if it is used incorrectly. Please strictly follow the following matters.

- Don't decompose them.
- Do not open holes, weld or fuse.
- Do not place the energy accumulator or gas spring near a combustion source.
- Do not throw them into the fire.
- When they are disposed of, the gas that is sealed shall be discharged. Please entrust it to the sales store of our company.



# Running gear

## 1. General Assembly Drawing of Excavator

The directions mentioned in this section are the directions shown by the arrows in the figure below.

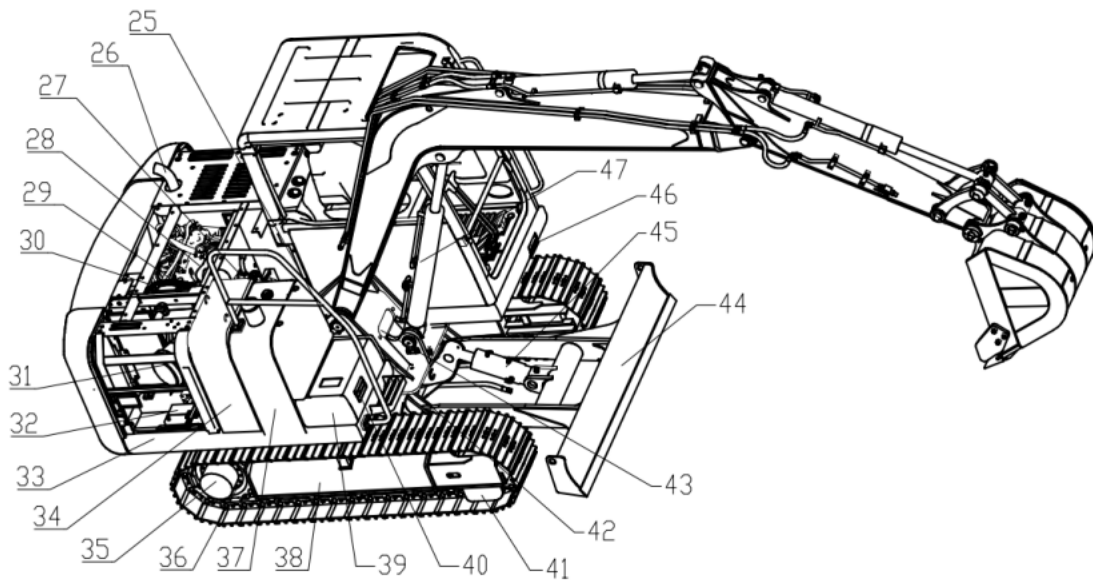
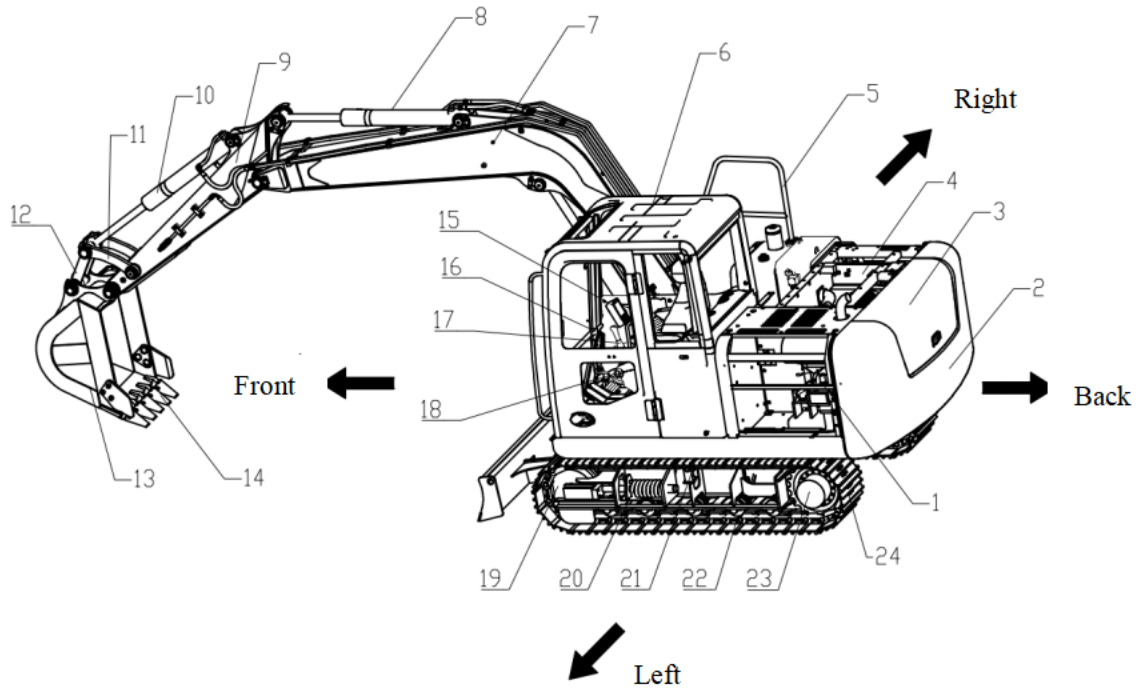

Symbol	Name	Symbol	Name	Symbol	Name
1	Main pump	17	Hand pilot valve	33	Upper swivel platform
2	Counterweight	18	Lifting hydraulic locking lever	34	Hydraulic oil tank
3	Rear hood	19	Guide wheel	35	Traveling motor (right)
4	Radiator	20	Tensioning device	36	Sprocket (driving wheel)
5	Handrails	21	Support roller	37	Fuel tank
6	Cab	22	Track roller	38	Lower structure
7	Boom	23	Traveling motor (left)	39	Storage box
8	Arm cylinder	24	Track assembly	40	Swivel platform working light
9	Arm	25	Rotary motor	41	Guard board
10	Bucket cylinder	26	Silencer	42	Pivoting support
11	Connecting rod	27	Master valve	43	Central rotary connector
12	Rocker	28	Engines	44	Dozer blade assembly
13	Bucket	29	Fuel filter	45	Dozer blade cylinder
14	Bucket teeth	30	Oil filter	46	Working light
15	Display	31	Air filter	47	Boom cylinder
16	Dozer blade operating handle	32	Battery		

## 2. General Assembly Drawing of Control Device and Instrument

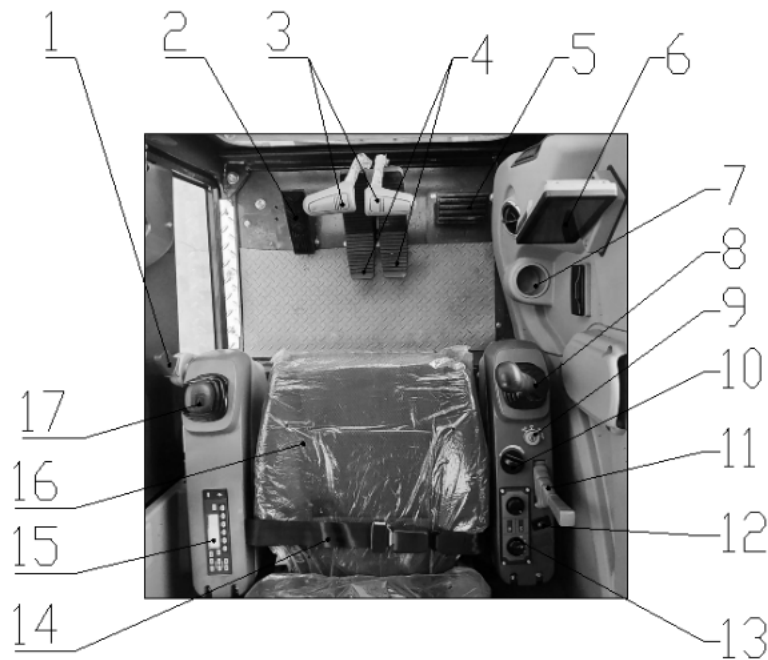

Symbol	Name	Symbol	Name
1	Lifting cutoff locking lever	11	※Dozer blade lift handle
2	Auxiliary line tread	12	※Rocker switches for lighting, etc.
3	Left and right travel lever	13	AC control panel
4	Left and right traveling treads	14	Seat belt
5	Footrest	15	※Radio
6	※Display	16	※Seat assembly
7	Sundries box	17	※Left pilot handle (with horn button)
8	Right pilot handle		
9	Start switch		
10	Throttle knob		

Note: If the ※ serial numbers are marked in front, the assembled accessories may vary due to the difference of model or spares.

## 2.1 Overview of Electronic Monitor

### Home Page Description

The home page display is as shown in Fig. 1. The home page mainly displays parameters such as work time, engine speed, system voltage, fuel level, water temperature, oil temperature, alarm, clock, and air pressure.

As shown on the first line of the home page, the contents such as the system voltage, working time, gear and time will be displayed respectively; Subsequently, the water temperature and fuel level dial will be displayed; The Icons near the dial are various alarm icons and working status; The key indicator icon is displayed at the bottom. Press F4 to enter the camera function, and press F1 to enter the menu page. See Appendix 1 for the functions corresponding to the key icons, and Appendix 2 for the description corresponding to the alarm icons.



### Menu Selection Page Description

The menu display page is as shown in Fig. 2. This page displays 6 functional menus corresponding to machine state, fault inquiry, maintenance log, user setting, advance setting, and machine information. The user can enter different function pages through this page to view or modify the relevant parameters setting of the instrument.

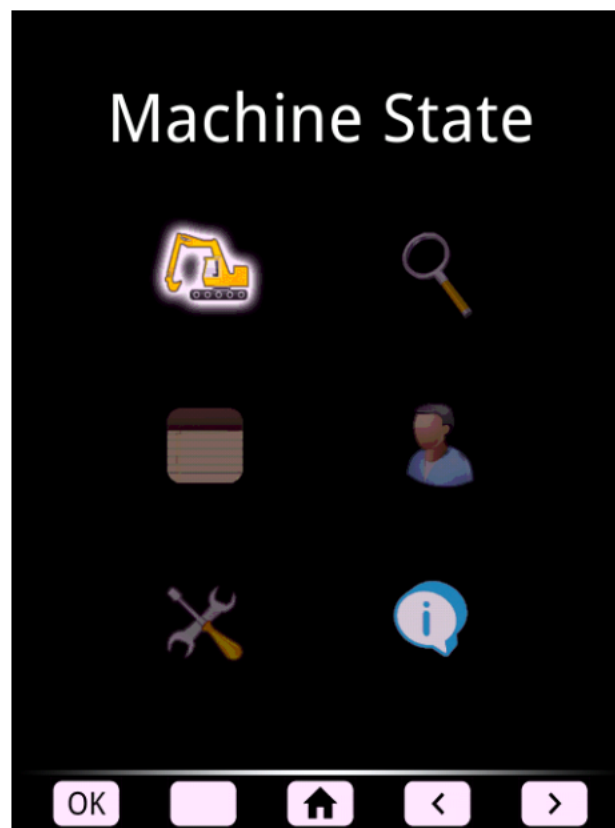

Fig. 2 Menu Display Page

On this page, press F4/F5 to switch the menu index, press F1 to enter the selected menu page, and press F3 to return to the home page.

### Machine State Description

On the menu selection page, select the machine state menu index and press F1 to enter the machine state page. The machine state page is divided into three sub-pages, namely, engine status, work status and port status. Switch among the three subpages by pressing F4/F5.

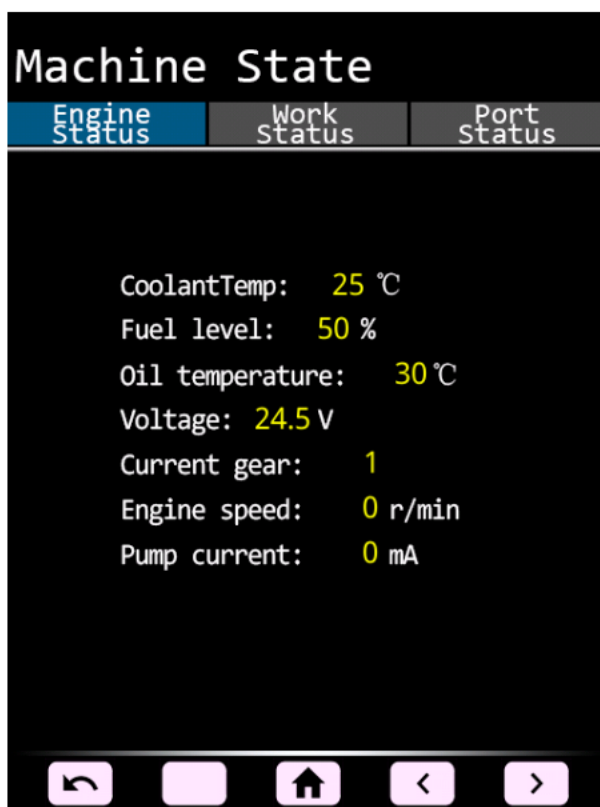

Fig. 3-1 Engine Status Page

The engine status page is shown in Fig. 3-1, which mainly displays some related data of the engine and data collected by the instrument sensor.

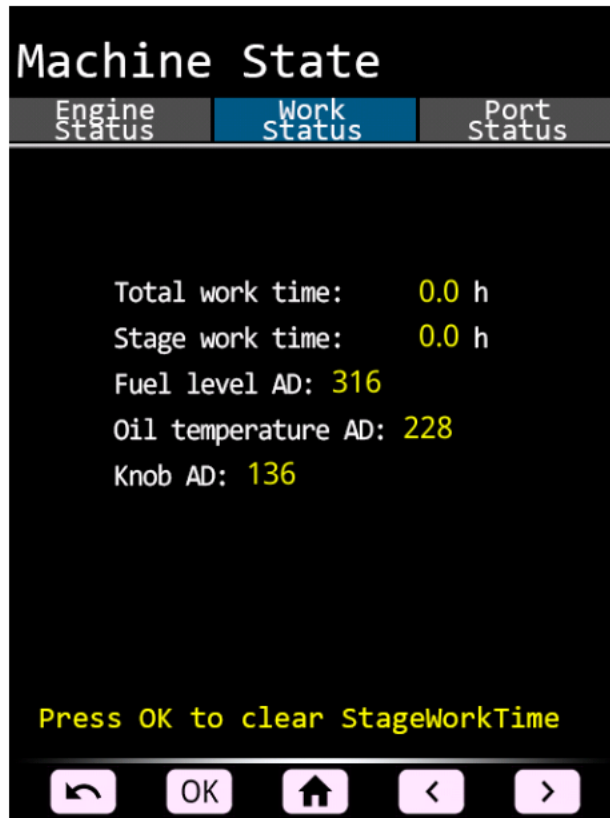

Fig. 3-2 Work Status Page

The work status page is shown in Fig. 3-2, which mainly displays the work time of the instrument and the data collected by the sensor.

The port status page is shown in Fig. 3-3, which mainly displays the input and output status of the instrument.

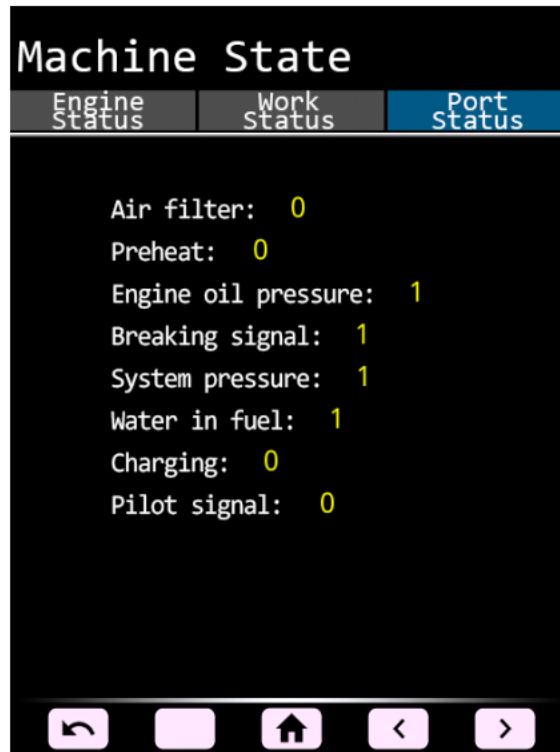

Fig. 3-3 Port Status Page

## Fault Inquiry Description

On the menu selection page, select the fault inquiry menu index and press F1 to enter the fault inquiry page. The fault inquiry page is divided into three sub-menus, namely, current fault, history fault and engine fault.

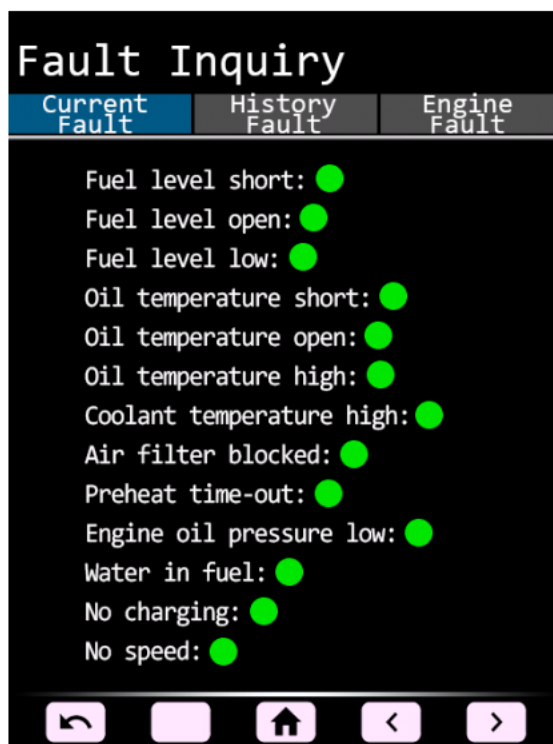

Fig. 4-1 Current Fault

The current fault indicates a fault that is occurring on a sensor at present, as shown in Fig. 4-1. A red dot is displayed when a fault occurs, and a green dot is displayed when no fault occurs.

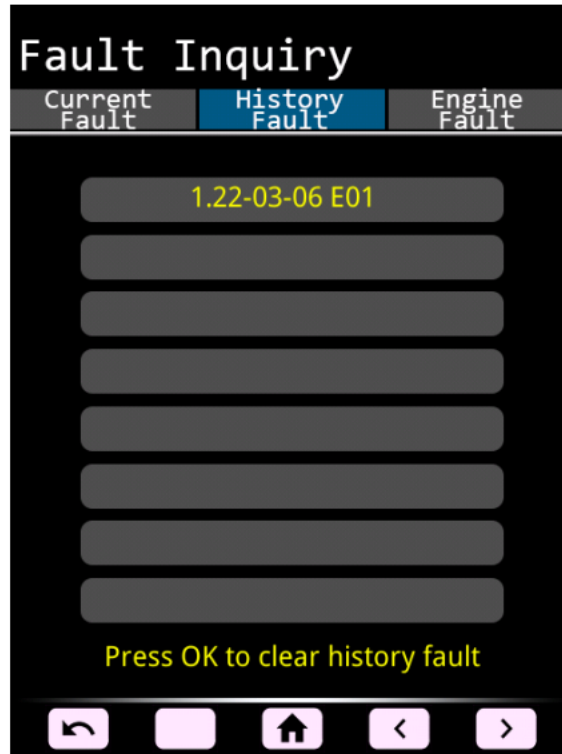

Fig. 4-2History Fault

The history fault records the time when the fault is sent, fault code, and fault description. Eight history faults can be stored at maximum. If the number of history faults exceeds eight, the earliest faults will be overwritten. As shown in Fig. 4-2, after the password is entered in the advance setting, press the key F2 on this page to clear the history faults stored.



Fig. 4-3 Engine Fault

As shown in Fig. 4-3, the engine fault page shows the current engine fault codes in SPN-FMI format. Eight current engine faults are displayed at maximum. When there is no engine fault, no engine fault is displayed on this page.

## Maintenance Log Page

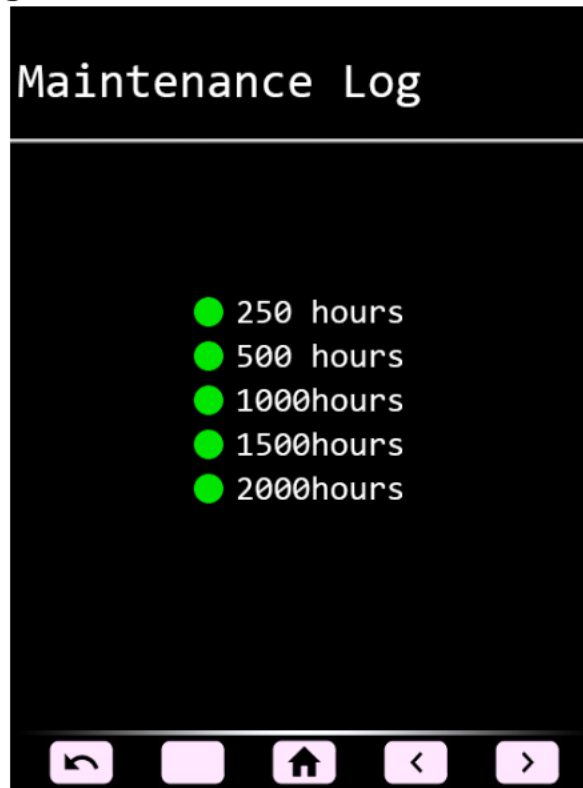

Fig. 5 Maintenance Log Page

On the menu selection page, select the maintenance log menu index and press F1 to enter the maintenance log page. The maintenance log page is used to remind the maintenance time. When the work time exceeds the maintenance log time, the corresponding time icon turns red, indicating the need for maintenance.

## User Setting

On the menu selection page, select the user setting menu index and press F1 to enter the user setting page. The fault inquiry page is divided into two sub-menus, namely, system time setting and language.

As shown in Fig. 6-1. The user setting page is used to set the date and time. On the page shown in Fig. 6-1, press F2 to open the page parameter editing function. Press F4/F5 to switch the cursor position, and F2/F3 to change the value of the parameter where the cursor is located. After the modification, press F1 to save and exit the editing function.

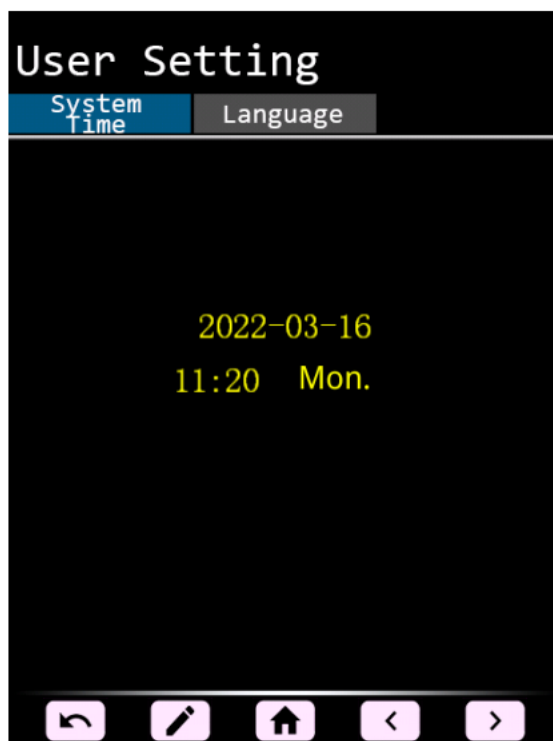

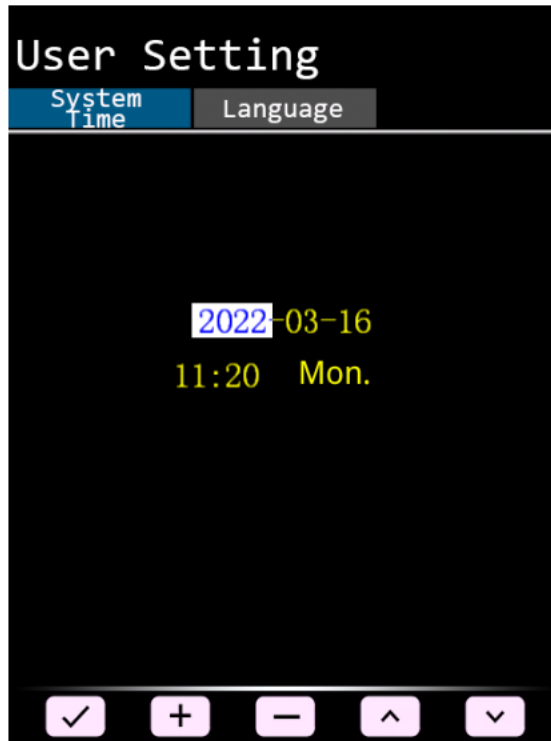

Fig. 6-1 User Setting

Fig. 6-2 User Setting Editing Page

As shown in Fig. 6-3. The language is used to switch between English and Chinese. On the page shown in Fig.6-3, press the key F2/F3 to switch between languages.

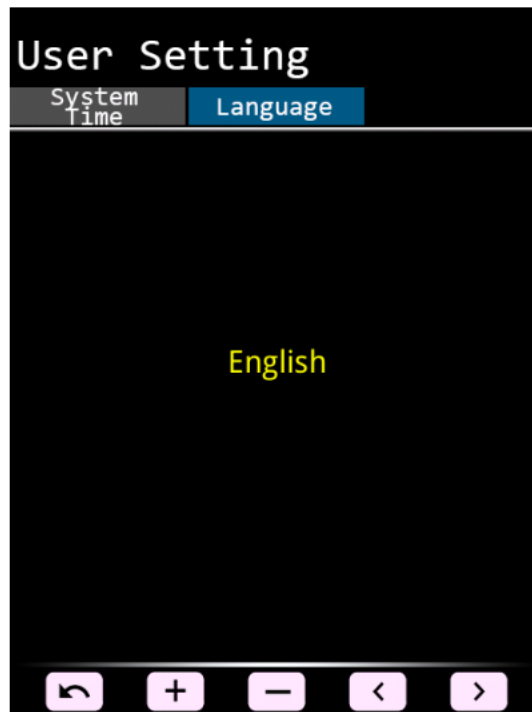

Fig. 6-3 Language

## Advance Setting

The advance setting page cannot be entered, until the password is entered. After the password is entered, the user may enter the advance setting page without entry of password, if the instrument is not restarted.

On the menu selection page, select the advance setting menu index and press F1 to enter the password entry page, as shown in Fig. 7-1.

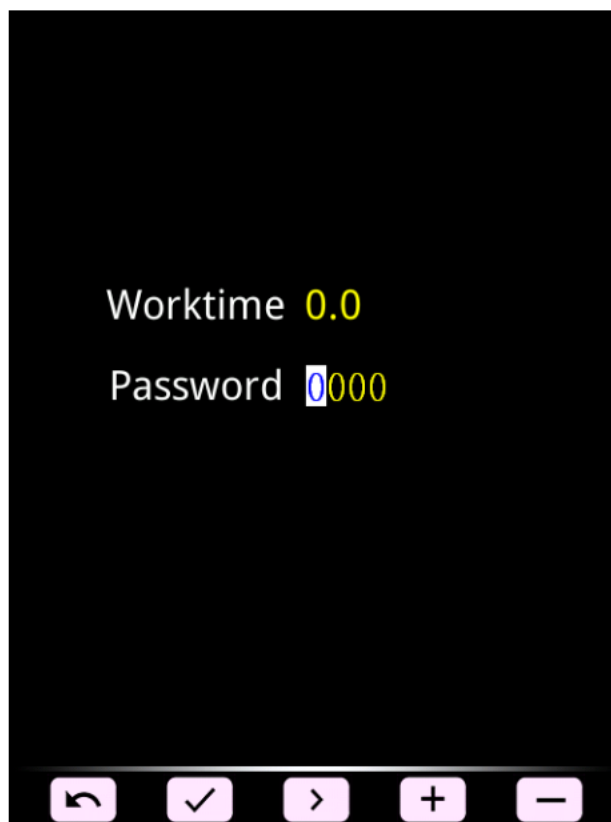

Fig. 7-1 Password Entry Page

On this page, press F3 to switch the cursor position, press F4/F5 to change the cursor position parameters, and press F2 to verify the password after its entry. If the password is correct, the basic parameters page as shown in Fig. 7-2 is displayed. **(Note: When pressing the F2 key, ensure that the cursor is at the last position. Otherwise, the password is incorrect)**

On the advance setting page, it is divided into two sub-menus, namely, basic parameters and functional parameters. Switch between two sub-menus by pressing the key F4/F5.

The basic parameters page is mainly used to modify the parameters related to the

vehicle and sensor, including model, number, work time, run time, oil temperature type, fuel level type, and logo set.

Gear, speed and current, knob gear correction, and hydraulic pump type are mainly set for the functional parameters.

On the page shown in Fig. 7-2, press F2 to open the basic parameters editing function. Then, enter the display page shown in Fig. 7-3. On this page, the user can modify relevant parameters such as the model and number, instrument work time, sensor type and engine control. The fuel level type and oil temperature type are 0 by default, and no modification is required in general.

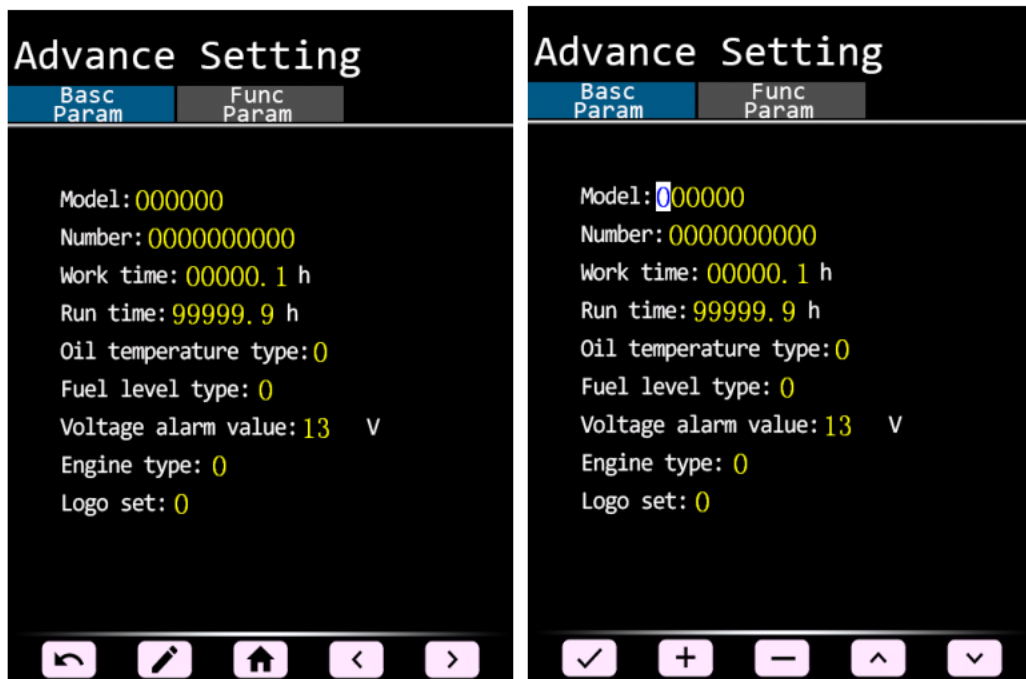

Fig. 7-2 Basic Parameters

Fig. 7-3 Basic Parameters Editing Page

The functional parameters pages are shown in Fig. 7-4 and Fig. 7-5.

On the page shown in Fig. 7-4, press F2 to open the basic parameters editing function. Then, enter the page shown in Fig. 7-5, where you can modify parameters such as gear, speed and current.

### Advance Setting

Basc Param		Func Param		
Gear	Speed	Current	KnobAD	100
01	1000	0	127	
02	1200	0	210	
03	1300	100	290	
04	1400	150	370	
05	1550	200	450	
06	1650	350	520	
07	1750	400	590	
08	1850	450	660	
09	1950	500	710	
10	2050	550	770	0

Navigation icons: Back, Edit, Home, Left, Right

Fig. 7-4 Power Setting

### Advance Setting

Basc Param		Func Param		
Gear	Speed	Current	KnobAD	100
01	1000	0	127	
02	1200	0	210	
03	1300	100	290	
04	1400	150	370	
05	1550	200	450	
06	1650	350	520	
07	1750	400	590	
08	1850	450	660	
09	1950	500	710	
10	2050	550	770	0

Navigation icons: Confirm, Plus, Minus, Up, Down

Fig.7-5 Power Setting Editing Page

## Machine Information

The information related to machine number and program version is displayed as shown in Fig. 8.

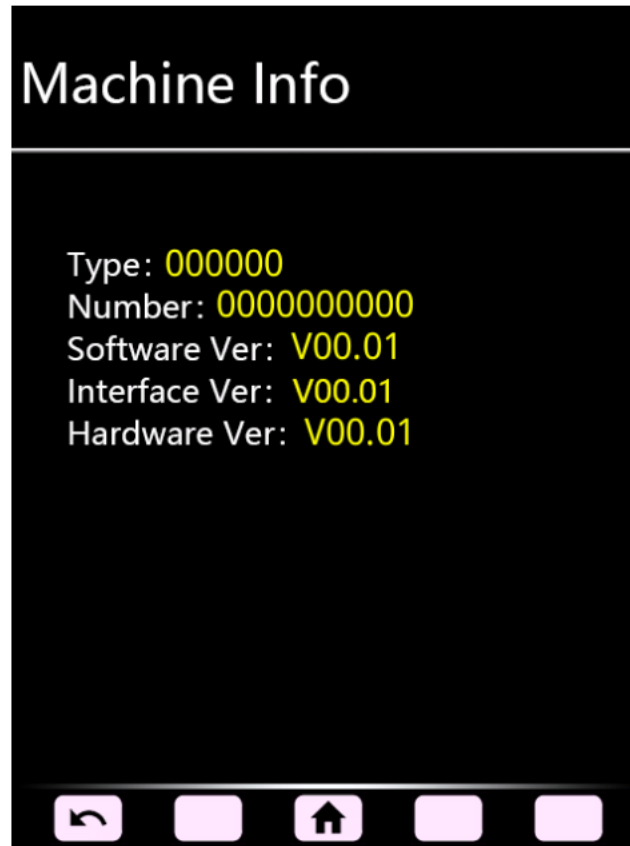

Fig. 8 Machine Information

## 2.2 Overview of Electronic Monitor

### 1 Main purpose and scope of application

JK5100HS 7" touch display control terminal (hereinafter referred to as "7" touch display control terminal") is a high-performance programmable 7" touch display control terminal developed by our company. It is mainly used to monitor and record various states of automatic control equipment, and set the enable and given values of each control.

### 2 Working environment conditions

Ambient temperature:  $-20^{\circ}\text{C}\sim+70^{\circ}\text{C}$

Storage temperature:  $-30^{\circ}\text{C}\sim+80^{\circ}\text{C}$

Relative humidity: 45%~75%RH

Atmospheric pressure: 86~106 KPa

Rated voltage of voltage grade: DC12V

Power supply fluctuation range: DC9~32V

Operation method: Adopt the touch screen

### 3 Main characteristics

The 7" touch display control terminal uses high-speed embedded STM32 microcontroller as the central processor, and FPGA as the coprocessor, and the circuit board is made of six-layer PCB board. It has the characteristics of high integration, high reliability, compact design, flexible configuration, powerful function, and economic benefits, and is an ideal solution for various monitoring applications.

### 4 Structure characteristics and working principle

The product mainly consists of circuits such as CAN communication circuit and

power input circuit.

#### 4.1 CAN communication port

The CAN communication port is a standard CAN communication port that CAN communicate with other devices with standard CAN communication ports.

#### 4.2 Power input circuit

The input power supply adopts ultra-wide voltage input technology. When the input voltage changes in a wide range of DC9V ~ 32V, the power supply can accurately output the normal 5V voltage, which ensures the reliable operation of the 7" touch display control terminal.

### 5 Product performance and specification

Item \ Specification	JK5100HS
Processor	32-bit microprocessor + FPGA, with the main frequency of 120 MHz
Type of screen	7" TFT
Display brightness	400 cd/m <sup>2</sup>
Resolution	800(H)×480(V)
Display color	Color 65536
Touch screen	7" single-point touch screen
Built-in buzzer	Yes
Calendar clock	Yes
Memory space	256KB RAM + 8KB EEPROM + 16MB SDRAM
Power input	DC9V~32V
Communication interface	1-circuit CAN
Protection class	Front IP65
Dimension	112(V)×179(H)×41(D)mm

### 6 Manual version information

#### Version information

Document name	JK5100HS 7" Touch Display Control Terminal Manual	
Current version	V1.0	
Completion date	May 28, 2024	
History record	Version	Date
	V1.0	May 28, 2024

## 2.2 Display Description of Electronic Monitor

As shown in Fig. 1, it is the main interface of JK5100HS 7" touch display control terminal after power-on, which can be divided into two display areas: State operation display area, and instrument parameter display area.





Fig. 1 Main Interface

### 1 State operation display area

#### ① Pilot switch indication

The indication is given according to the state of the pilot safety lock of the machine.

 is displayed when the pilot lock is pulled up.  is displayed when the pilot lock is put down.



#### ② Preheating signal indication

The indication is given according to the preheating state of the machine.  is





displayed when the machine is in preheating state, and  is displayed when the

machine is not in preheating state.



③ Air filter blocking alarm (reservation)

The indication is given according to the air filter blocking alarm state.  is displayed when the air filter is blocked, and  is displayed when no air filter is blocked.

④ Charging alarm

The indication is given according to the charging alarm state.  is displayed when there is charging alarm, and  is displayed when there is no charging alarm.  is displayed when the charging is prohibited, and  is displayed when it is charging.

⑤ Engine oil pressure alarm

The indication is given according to the engine oil pressure alarm.  is displayed when there is engine oil pressure alarm, and  is displayed when there is no engine oil pressure alarm.

⑥ Display in Beijing date and time

Display the MM/DD/YYYY information according to the Beijing time.

**2001 - 01 - 01**

⑦ Display in Beijing time

Display the HH/MM/SS information according to the Beijing time.

**01 : 01**

⑧ Cooling water temperature indication (CAN communication)



The indication is given according to the current cooling water temperature of the machine,  displays the range of 35°C-140°C.

⑨ Fuel level indication (AI05)

The indication is given according to the current fuel level percentage of the machine,

 displays range of 0%-100%.

#### ⑩ Working hour indication

When the machine starts timing,  and  alternately flash, and  keep unchanged after the timing is stopped.

The indication is given according to the current cumulative time, in the range of 0h-999,999.9h and with the accuracy of 0.1h.

#### ⑪ Display of fault alarm text

When there is no fault in the machine, it's displayed as follows:





When there is any fault in the machine, the fault text is displayed, for example:





If there are multiple faults, the scrolling display is given in turn.

#### ⑫ Working light switch

The working light is off by default, when the machine is powered on.  is displayed for the working light switch. Press the working light switch,  is displayed for the working light switch, indicating that the working light is on. Continue to press the working light switch, the working light switch returns to the off state.

#### ⑬ Wiper switch

The wiper switch is off by default, when the machine is powered on.  is displayed for the wiper switch. Press the wiper switch,  is displayed for the wiper switch, indicating that the wiper acts. Continue to press the wiper switch, the wiper switch returns to the off state.

#### ⑭ Menu key

In the main interface, press the menu key  to pop up the main menu page.

In the main menu page, press the menu key to return to the main interface.

#### ⑮ High/low speed switch

The high/low speed switch is low speed by default, when the machine is powered on,



is displayed for the high/low speed switch. Press the high/low speed switch,



is displayed, indicating that the machine is switched to high speed. Continue to press the high/low speed switch, the high/low speed switch returns to the low speed state.

#### ⑯ Wiper spray switch

The wiper spray switch is off by default, when the machine is powered on.  is

displayed for the wiper spray switch. Press the wiper spray switch, the wiper keeps

spraying and  is displayed for the wiper spray switch, indicating that the wiper is

spraying. Continue to press the wiper spray switch, the wiper spray switch returns to the off state.

#### ⑰ Buzzer mute key

When the instrument buzzer does not sound,  is displayed for the buzzer mute key, there will be no effect after pressing this key.

When the instrument buzzer doesn't sound,  is displayed. When the buzzer

sounds,  is displayed. Then press this key to mute the instrument buzzer. After

muting,  is displayed. Continue to press the buzzer mute key. Then, the buzzer will return to the sound state.

#### ⑱ Idle state

The idle state is enabled by default during power-on. When the idle state is enabled,



is displayed. When the idle state is closed,



is displayed.

## ⑱ Home video

The home video is enabled by default during power-on. Click the icon  to open and close the home video.

## 2 Middle instrument display area

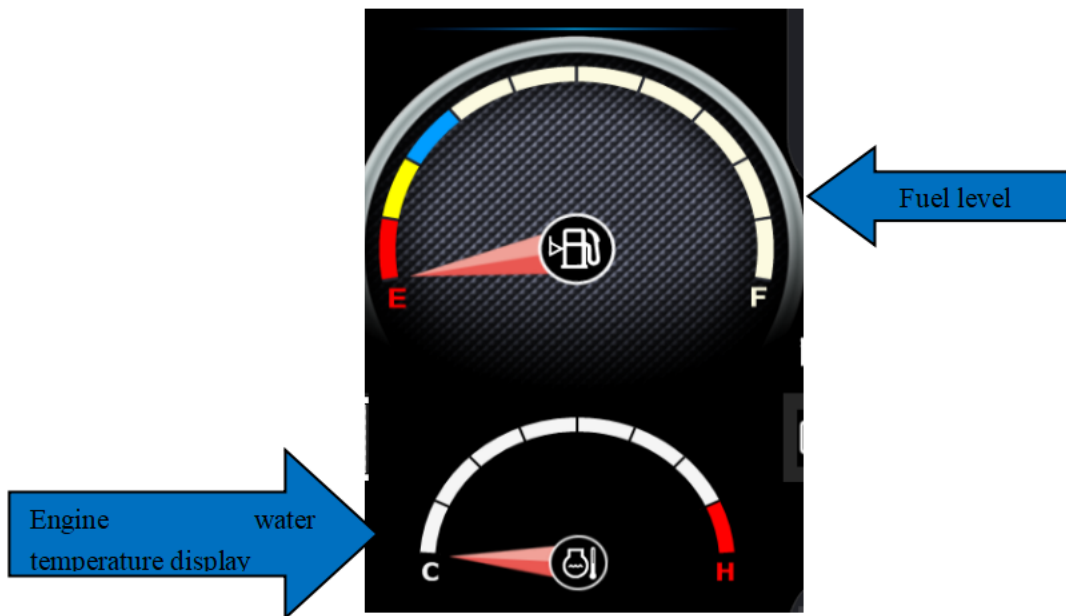

Fig. 2 Middle Instrument Display Area

Water temperature instrument: The display range is 35~140°C;

Fuel level instrument: The display range is 0~100%.

## 2.3 Sensor Information Acquisition Description of Electronic Monitor

### 1 Parameters of fuel level sensor

The signal wire of the fuel level sensor is connected to AI05 (X-1/23), the display terminal automatically determines the corresponding resistance value, and the corresponding fuel level display value is displayed on the interface. The fuel level display range is 0-100%.

### 2 Water temperature CAN communication

The display terminal reads the engine water temperature data, analyzes the data, and displays the corresponding engine water temperature display value (°C) on the

interface.

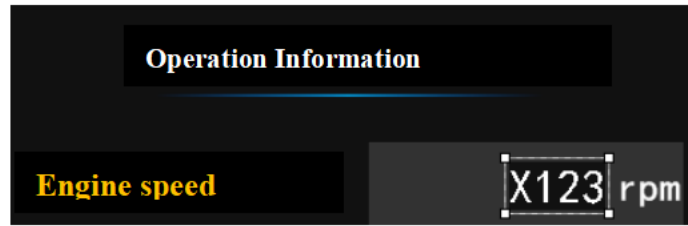

### 3 Speed CAN communication



The display terminal reads the engine rotation speed data, analyzes the data, and displays the corresponding engine rotation speed display value (rpm) on the interface.

## 2.4 Operation Instructions of Electronic Monitor

### 1 Main menu

In the main interface (as shown in Fig. 1), press  to enter the "main menu" interface, as shown in Fig. 3. Press  to return to last page. Press  to return to Home screen.

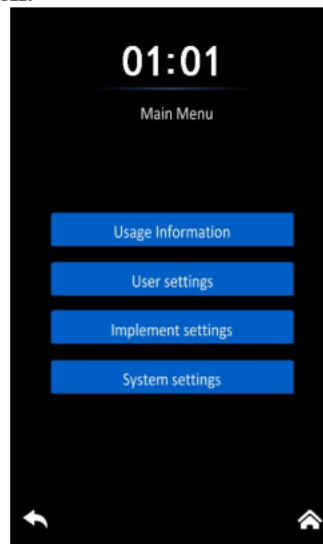

Fig. 3 Main Menu

The user may touch the menu key

. The 7" touch display control terminal will enter the corresponding display interface. For setting of machines and tools, this function is not available for this version, and the prompt will appear in the form of text.

## 2. Use information

In the "main menu" state (as shown in Fig. 3), touch "usage information" option to enter the "usage information" menu interface, as shown in Fig. 4.

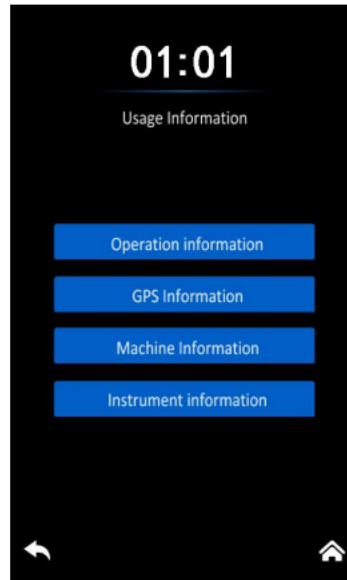

Fig. 4 Usage Information

The user may touch the menu key. The 7" touch display control terminal will enter the corresponding display screen. The user can select the options to view the operation information (Fig. 5), machine information (Fig. 6), and instrument information (Fig. 7) of the current machine. For GPS information, this function is not available for this version, and the prompt will appear in the form of text.

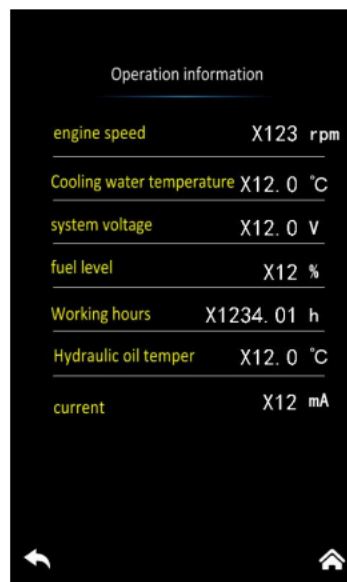

Fig. 5 Operation Information

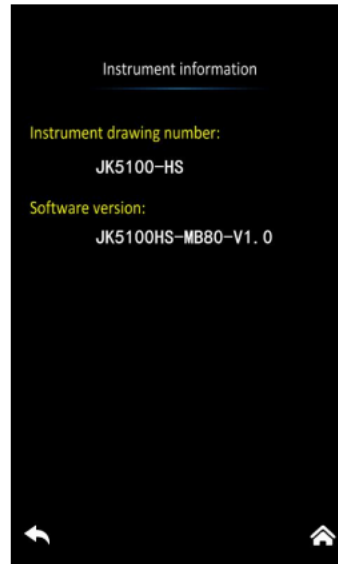
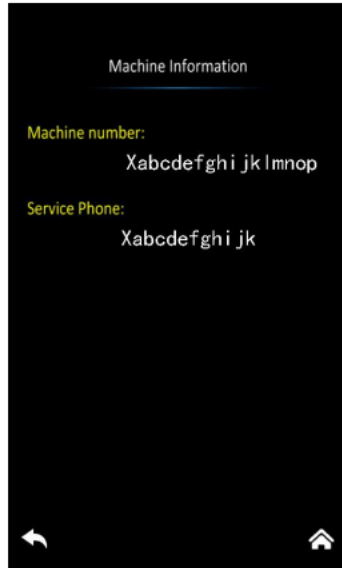

Fig. 6 Machine Information Fig. 7 Instrument Information

The user can enter the password interface of the operation information by touching the please input a password page (Fig. 8), and enter the debug information menu page (Fig. 9) after entering the password.

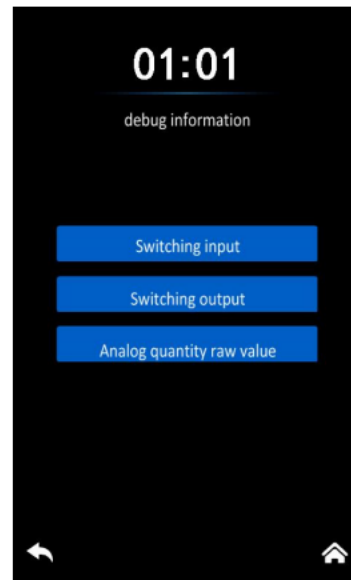
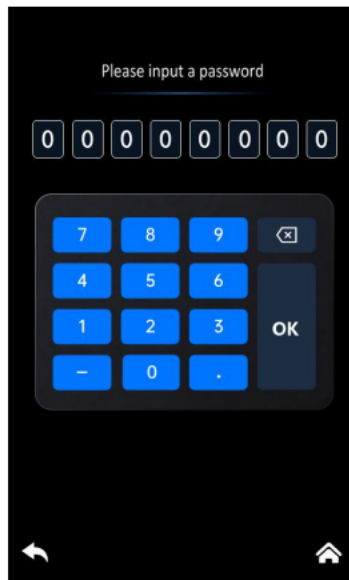

Fig. 8 Please Input a Password

Fig. 9 Debug Information

The user can view the switching input (Fig 10), switching output (Fig. 11), and analog quantity raw value (Fig. 12) of the current machine by selecting the options

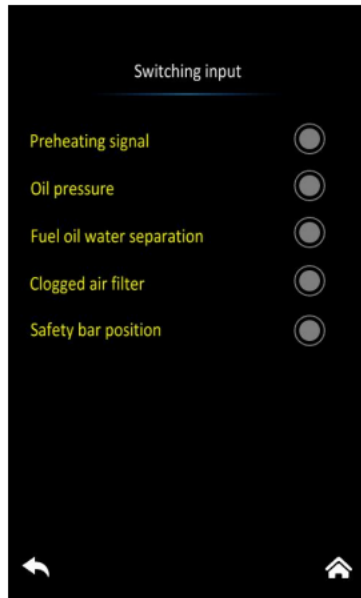

Fig. 10 Switching Input

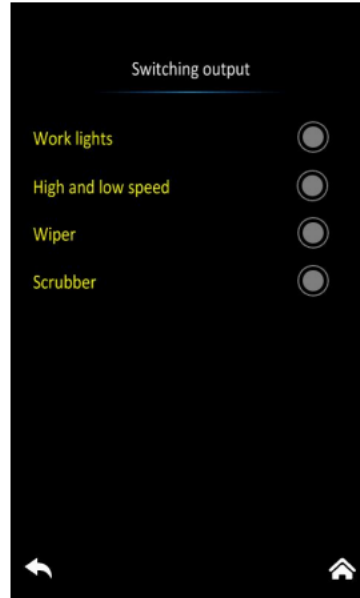

Fig. 11 Switching Output

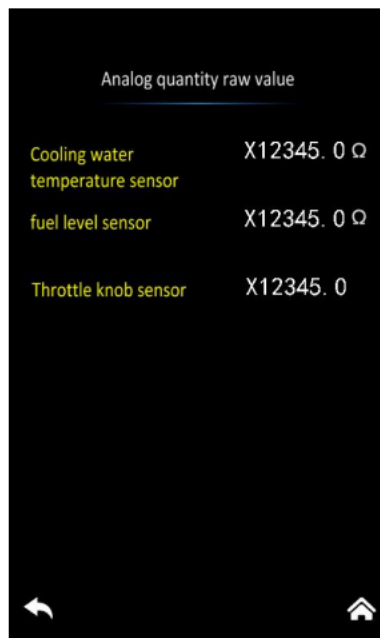

Fig. 12 Analog Quantity Raw Value

### 3 User setting

In the "main menu" state (as shown in Fig. 3), touch the option "user settings" to enter the password interface (Fig. 13) at first, and then enter the "user settings" menu interface after entering the password, as shown in Fig. 14.

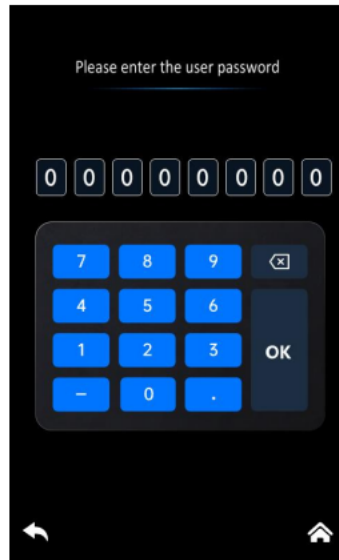

Fig. 13 Please Enter the User Password

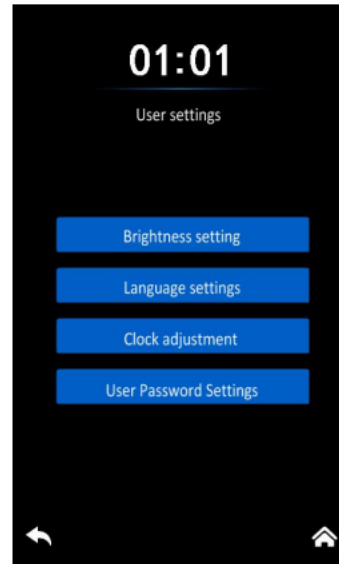

Fig. 14 User Settings

The user may touch the menu key. The 7" touch display control terminal will enter the corresponding display screen. The user can modify the brightness setting (Fig. 15), Language setting (Fig. 16), clock adjustment (Fig. 17), and user password setting (Fig. 18) of user-related setting parameters by selecting the options.

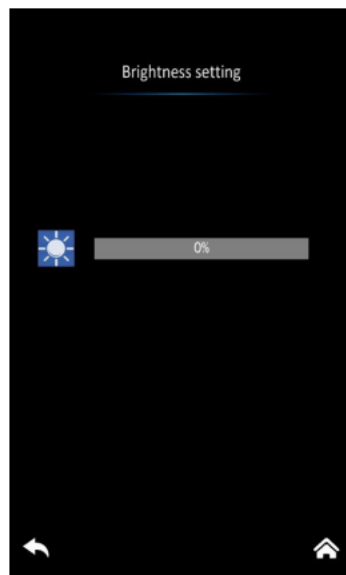

Fig. 15 Brightness Setting

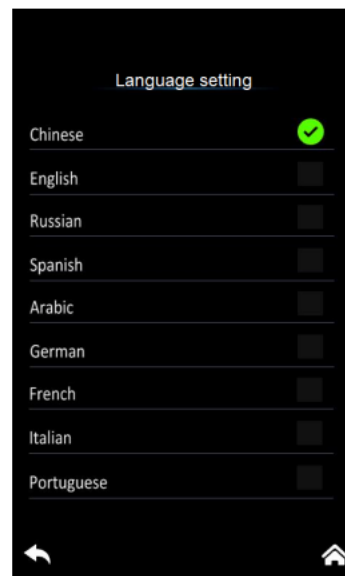

Fig. 16 Language setting

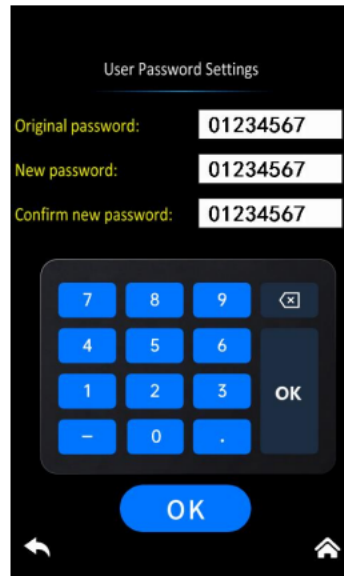

Fig. 17 Clock Adjustment Fig. 18 User Password Settings

#### 4 System settings

In the "main menu" state (as shown in Fig. 3), touch the option "system settings" to enter the password interface (as shown in Fig. 20), and then enter the "system settings" menu interface after entering the password, as shown in Fig. 21.

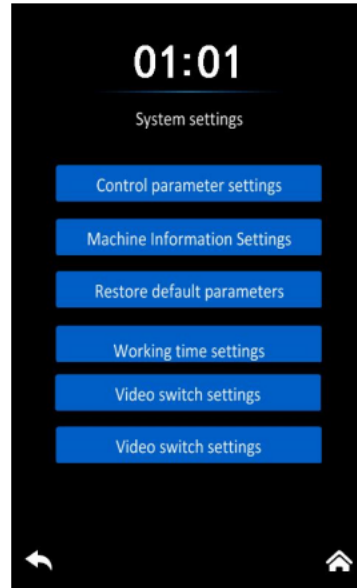
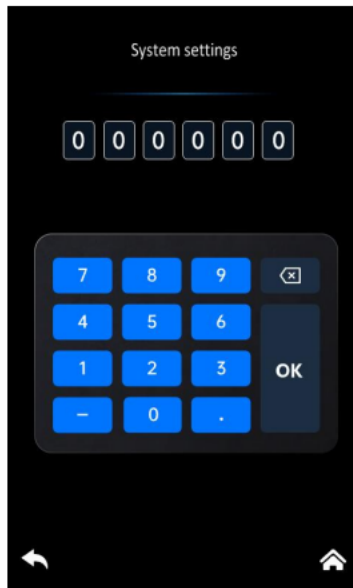

Fig. 20 System Settings Fig. 21 System Settings

In the system settings interface (as shown in Fig. 21), touch the option "control parameter settings" to enter the control parameter setting interface, as shown in Fig. 22:

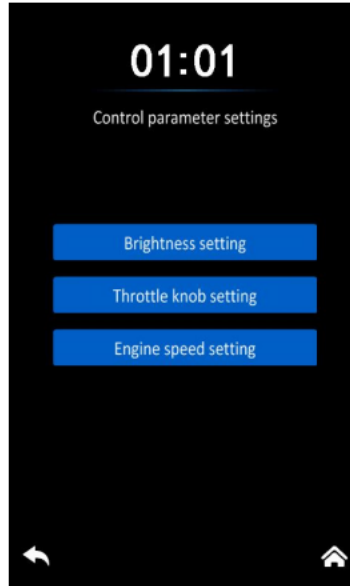

Fig. 22 Control Parameter Settings

The user may touch the menu key. The 7" touch display control terminal will enter the corresponding display screen. The user can select the options to view the alarm point settings (Fig. 23), engine rotation speed setting (Fig. 24), and current setting (Fig. 25) of the current machine. On the alarm point setting interface, the user can click the page skip key to turn the page; On the speed setting interface, the user can click "engine speed setting" to skip to the speed setting interface.

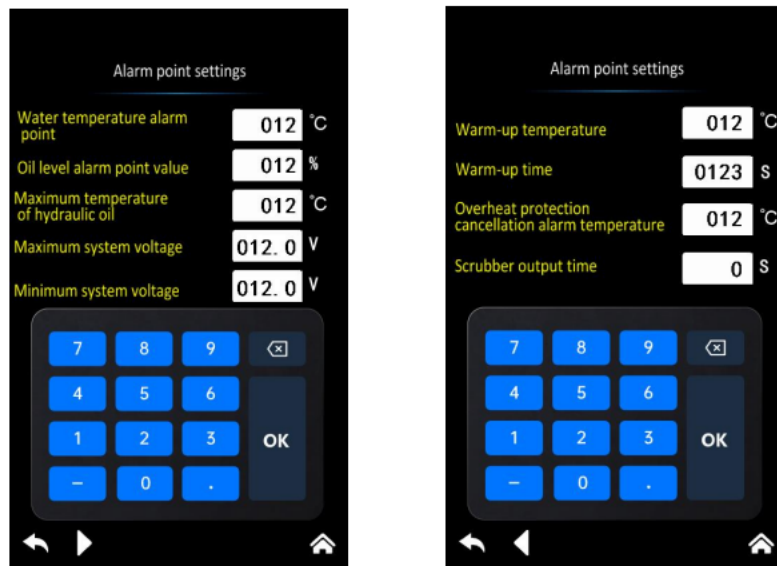

Fig. 23 Alarm Point Settings



Fig. 24 Engine Speed Setting

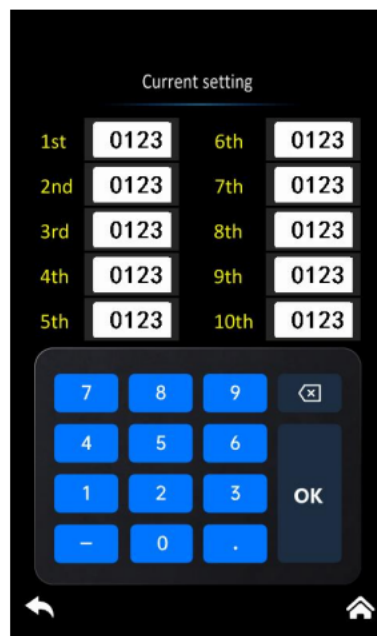

Fig. 25 Current Setting

In the system settings interface (as shown in Fig. 21), touch the option "restore default parameters" to enter the "restore default parameters" interface, as shown in Fig. 26:

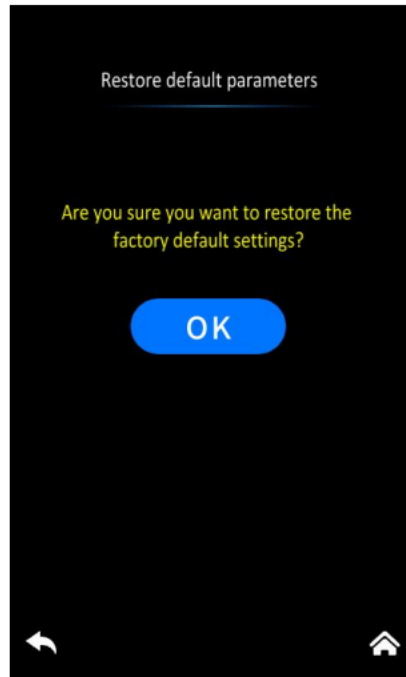

Fig. 26 Restore Default Parameters

In the system settings interface (as shown in Fig. 21), touch the option "machine information settings" to enter the machine information setting interface, as shown in Fig. 27:



Fig. 27 Machine Information Settings

In the system settings interface (as shown in Fig. 21), touch the option "working time settings" to enter the working time password interface at first, and then enter the working time setting interface after entering the password, as shown in Fig. 28:

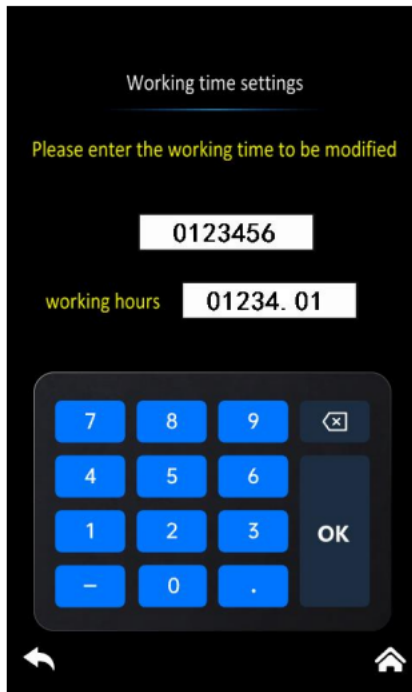

Fig. 28 Working Time Settings

In the system settings interface (as shown in Fig. 21), touch the option "video switch settings" to enter the video switch setting interface, as shown in Fig. 29:

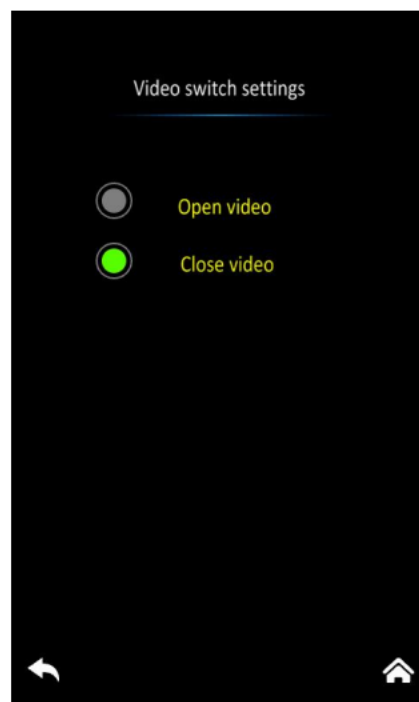

Fig. 29 Video Switch Settings

In the system settings interface (as shown in Fig. 21), touch the option "throttle knob setting" to enter the throttle knob setting interface, as shown in Fig. 30:

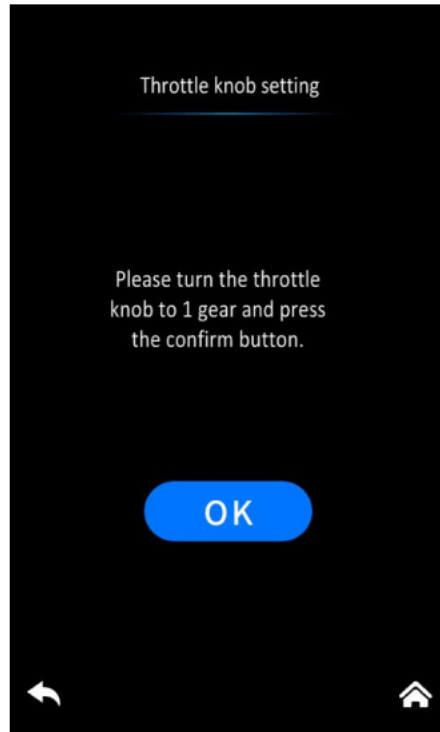

Fig. 30 Throttle Knob Setting

## 2.5 Installation Description of Electronic Monitor

### 1 Installation method

The external mounted installation method is adopted for the monitor.

### 2 Appearance and installation dimensions

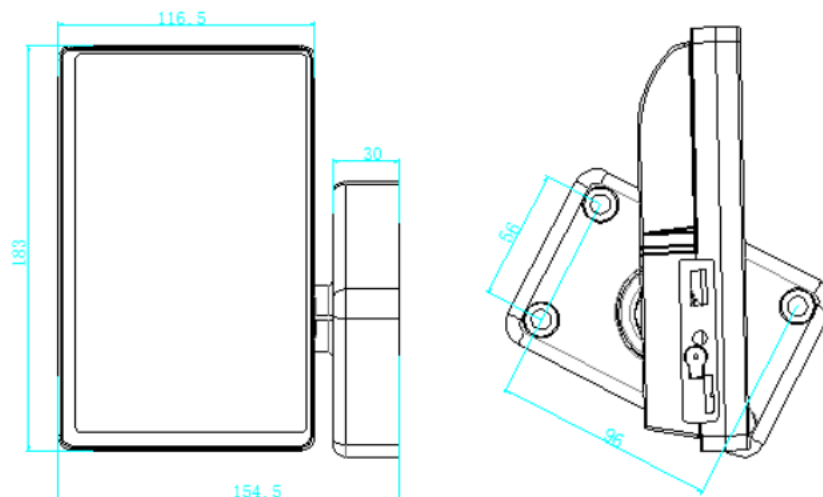

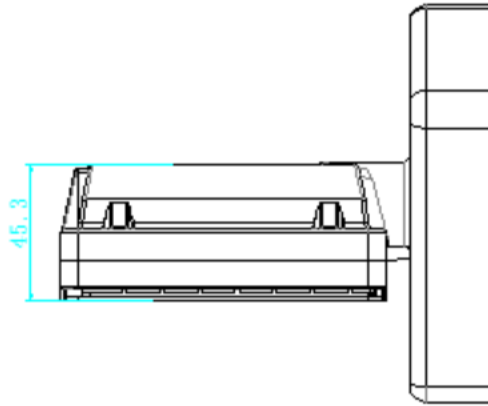

Fig. 31 External Dimensions Drawing

### 3 Description on port definition

The monitor adopts 14-core and 9-core KET connectors, and the specific wiring description is shown in Fig. 32

X1-1				X1-2			
Code of pin position	Name of pin position	Function definition	Description of function	Code of pin position	Name of pin position	Function definition	Description of function
1	AI07	Input of 0-5V analog quantity	Information of knob position	1	PWM07	PWM output	PWM output
2	DI07	Switching input 07	Charging information (generator L)	2	DI05	Switching input 05	Automatic idling signal
3	DO00	High side switching output 00	Working light	3	DI02	Switching input 02	Crushing mode signal
	CANL	CAN communication	CANL	4	DIO1	Switching input 01	Engine oil pressure
5	VIN-	Power input negative pole	Grounding	5	AIO4	Input of 100Ω analog quantity 04	Hydraulic oil temperature
6	5VG	Sensor ground	Communication ground	6	AI05	Input of 100Ω analog quantity 05	Fuel level
7	5V	Power output	Knob 5V	7	DI03	Switching	Preheating

		of the sensor				input 03	signal
8	DO05	High side switching output 05	Spray motor	8	DI00	Switching input 00	Air filter alarm
9	VIN+	Power input positive pole	Instrument power	9	DI06	Switching input 06	Oil and water separator
10	CANH	CAN communication	CANH				
11							
12	DIO4	Switching input 04	Safety bar position				
13	DO06	High side switching output 06	High and low speed switching				
14	DO01	High side switching output 01	Wiper switch				

X1-1 MG640352-5

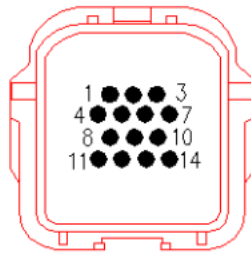

Incoming Line Terminal

X1-2 MG610346-5

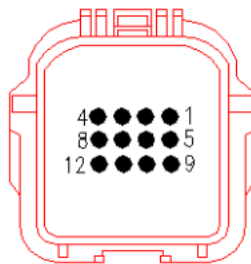

Incoming Line Terminal

Fig. 32 Port Definition Diagram

## 2.6 Use and Operation of Electronic Monitor

1. Please read the product manual carefully before use;

2. The wiring of peripheral devices shall be carried out in strict accordance with the requirements of the port definition diagram (as shown in Fig. 32);

3. Before power-on, carefully check whether the power supply, grounding line and communication line are correctly connected.

### **2.7 Common Faults and Handling of Electronic Monitor**

1. When an abnormality occurs, check whether the power supply voltage and related connector leads are loose.

2. The 7" touch display control terminal is a professional product. Therefore, non-professionals are not allowed to disassemble the machine for repair.

3. If there are other problems, please contact the manufacturer.

### **2.8 Repair and Maintenance of Electronic Monitor**

There are no consumable parts in the 7" touch display terminal that shorten its service life.

### **2.9 Transportation and Storage of Electronic Monitor**

#### **1 Package**

The 7" touch display terminal shell is packed in 2 mm thick corrugated paper, the interior is filled with foams, and the monitor itself is packed in a plastic bag.

#### **2 Transportation**

The monitor is suitable for sea, land and air transportation, and shall be rainproof in transportation and handling, preventing from falling and smashing.

#### **3 Storage**

The electronic monitor shall be stored in a well-ventilated and dry warehouse without toxic gases.

### **2.10 Product Completeness of Electronic Monitor**

Table 1 Product completeness

No.	Nome and Specification	Unit	Quantity	Remarks
1	JK5100HS 7" Touch Display Control Terminal	Set	1	

2	Manual	Piece	1	
3	Packing list	Piece	1	
4	Product certificate	Piece	1	

### **2.11 Ordering Instructions of Electronic Monitor**

Please note the following contents upon ordering:

1. Required resource needs and relevant parameters of all resources.
2. Input voltage range of the power supply.

### **2.12 Warranty Rules of Electronic Monitor**

The user shall use, maintain and store the products in accordance with the manufacturer's product manual.

### 3. Use at the start and end of the season

#### At the start of the season

For optimal and comfortable air conditioner performance, have our sales store check and maintain your unit before the cooling season begins.

#### At the end of the season

After the season ends, run the air conditioner once a week for a few minutes each time.

This practice prevents oil shortages in various parts of the compressor and ensures the air conditioner remains in peak condition.

#### Notes on the use of air conditioners:

To ensure proper installation and use of the air conditioner, and to achieve satisfactory results, read this manual carefully and pay attention to the following prompts:

**Caution:** This prompt emphasizes that non-compliance may result in damage to the components.

**Note:** This prompt emphasizes that non-compliance may cause the air conditioning system to malfunction or perform poorly.

#### 3.1 Air conditioner operation and use

The PS series engineering vehicle air conditioner controllers mainly include three types: analog, digital, and intelligent.

##### 1. Analog air conditioner controller

##### 3.1.1 Introduction to analog panels

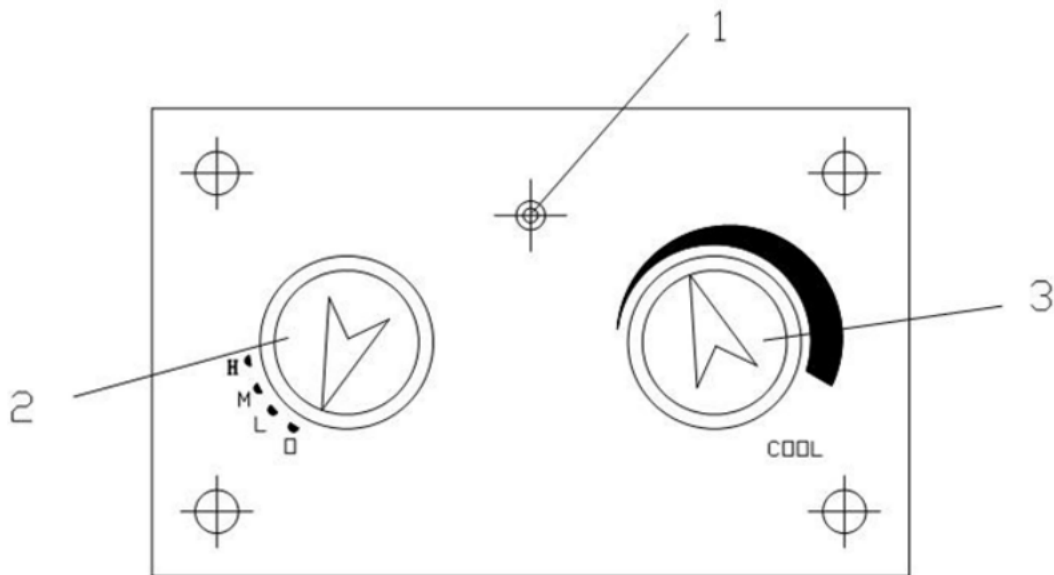

1. Work indicator

2. Air volume and power  
switch

3. Temperature control  
switch

##### 3.1.2. Electrical principles

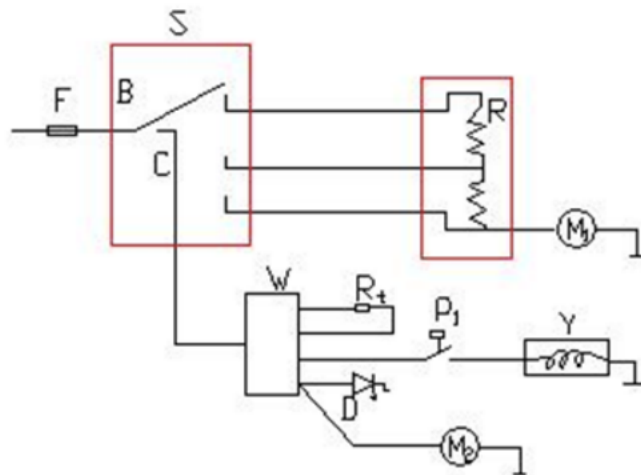

General electrical schematic diagram

Keys:

F- Insurance

S- Air volume switch

R- Speed control resistor

D- Indicator

M<sub>1</sub>- Evaporator fan

W- Thermostat

R<sub>1</sub> - Temperature sensing probe

B - Pressure switch

Y- Compressor electromagnetic clutch

M<sub>2</sub> - Condensate fan

### 3.1.3. Operating methods

#### 3.1.3.1 Cooling

##### 3.1.3.1.1 Start the engine.

##### 3.1.3.1.2 Turn the air volume and power switch to the maximum setting (H position).

3.1.3.1.3 Set the temperature control switch to the maximum cooling setting (COOL position), which should activate the indicator.

3.1.3.1.4 The air conditioner will begin to cool. Once the desired temperature is reached, adjust the temperature control switch back until the indicator turns off.

3.1.3.1.5 Adjust the air volume and power switch to set the desired air volume. There are three levels: High (H), Medium (M), and Low (L). After achieving the suitable temperature, it is recommended to reduce the air volume to the Medium (M) or Low (L) level

##### 3.1.3.1.6 Adjustment of air outlet direction

#### 3.1.3.2 Heating (engine circulating water)

##### 3.1.3.2.1 Start the engine.

##### 3.1.3.2.2 After the coolant temperature rises, open the water circuit valve.

##### 3.1.3.2.3 Turn on the air volume and power switch, and adjust the air volume as needed.

**Note: When cooling in summer, turn off the heating water valve. When heating in winter, turn off the cooling temperature control switch**

## 4. Use of seat belts

### A Warning About the seat belt assembly

- Be sure to fasten the seat belt when operating the machine. In the event of an inversion or similar incident, there is a risk of severe impact inside the cab or being thrown out of the cab, potentially leading to a major disaster or fatal accident.
- Please confirm the bolts of the assembly anchors on the seat are securely fastened. If they are loose, tighten them accordingly.
- Replace the seat belts every 3 years even if there are no anomalies in appearance. The year of manufacture is indicated on the back of the tape.

It is not necessary to adjust the length of the seat belt as it has a winding mechanism.

### 4.1 How to fasten seat belts

1. Please confirm that the seat belt (1) is not twisted and pull out the seat belt. Pull out the seat belts a little more.

2. Insert it until the buckle (2) clicks. The length will automatically adjust and lock when released.



### 4.2 How to unbuckle the seat belts

Press the red button (3) on the buckle (2) to unbuckle the seat belt (1).

## 5. Use of driver's seat

The driver's seat position can be adjusted. Adjust the position of the seat so that you can easily operate both the operating lever and the operating pedal.

## A Attention

When adjusting the driver's seat, be careful to avoid pinching your hand by the handle and seat bracket.

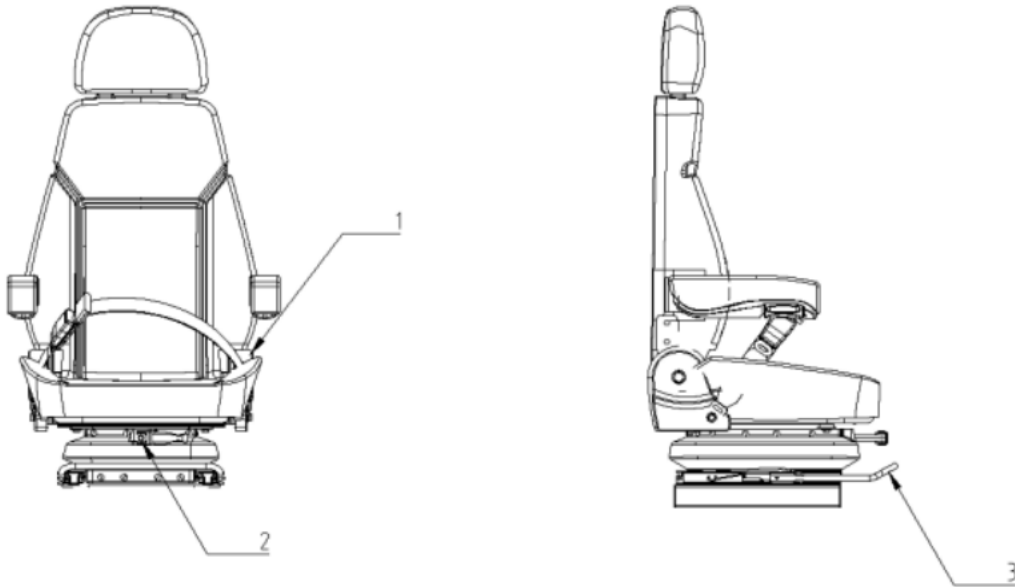

### 5.1 Height adjustment

The driver's seat height can be adjusted.

- Rotate button 3 to adjust the seat height.

### 5.2 Seat back tilt adjustment

The seat back tilt can be adjusted.

- Lifting the handle (1) adjusts the tilt of the front of the seat, moving it up and down.
- Pressing the handle (1) adjusts the tilt of the rear of the seat, moving it up and down.

After adjustment, release the handle to secure the seat in place.

### 5.3 Seat fore and aft adjustment

The driver's seat forward or backward position can be adjusted.

- Lift the handle (3) and move the seat to slide it forward or backward.

After adjusting the seat to the desired position, release the handle to securely lock it in place. (Adjustment range: 80 mm)

### 5.4 Armrest adjustment

Lift the handrails to raise it and adjust its angle.

### 5.5 Headrest adjustment

The headrests are adjustable up and down, as well as forward and backward.

- To adjust the headrest, hold it with both hands and gently move it up or down.
- To adjust the headrest forward or backward, hold it with both hands and gently move it to your preferred position.

## 6. Use of parts in the cab

### A Warning When leaving the driver's seat

Do not leave the cab while the engine is still running.

Before leaving the driver's seat, ensure to place the lifting hydraulic locking lever in the locked position and then stop the engine.

Accidentally touching the operating lever when the lifting hydraulic locking lever is not secured can result in a serious fatal accident.

### 6.1 Unlocking and locking of cab's door

Insert the key into the lock cylinder and turn the key to the left to open the door.

- Note that if you set the lock cylinder to the locked position before closing the door, the door will remain locked once closed.

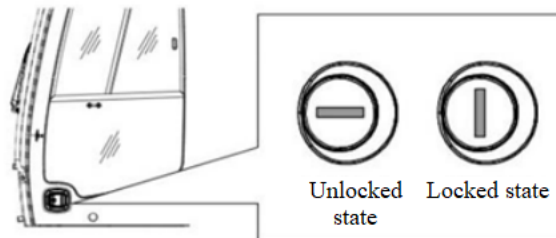

### 6.2 Driver's door lock

#### A Attention

During operation, ensure that the doors are securely locked, regardless they are open or closed. If the doors are not locked properly, they may open and close unintentionally, posing a significant danger. And it can lead to malfunctions.

This step is used to lock the door in the open state.

- Push the door to the latch section (1) and ensure it is locked.
- When closing the door, move the handle (2) on the left side of the driver's seat in the direction of the arrow. The latch will come off.

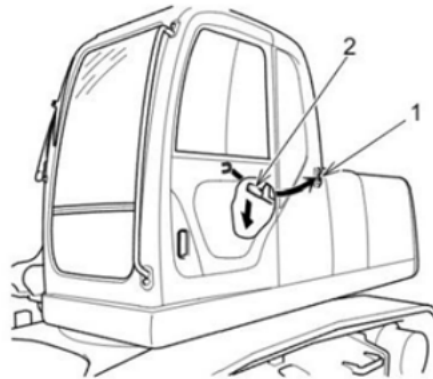

### 6.3 Opening the door from inside the cab

To open the door from inside the cab, simply move the handle (1) in the direction of the arrow, and the door will open.



### 6.4 Opening and closing of the front window (upper)

#### A Warning About the opening and closing of the front window (upper)

- Ensure that the body is level and securely locked before opening or closing the front window. It's especially important to note that there is a risk of the front window falling if it is unlocked while in a forward-leaning position.
- When closing the front window, it tends to drop more quickly due to its weight. Hold the window closed firmly with both hands.
- When opening or closing the front windows, lift the lifting hydraulic locking lever to the "locked position" and stop the engine.

#### A Attention

When opening and closing the front window, raise and lower it slowly, avoid getting your hands or any other objects caught. Operation without ensuring that the lever is properly locked or secured in place can be extremely hazardous. Please confirm it is properly locked.

1. Move the machine to a sturdy and level place.
2. Please let the bucket touch the ground.
3. Please stop the engine and place the lifting hydraulic locking lever in the locked position.

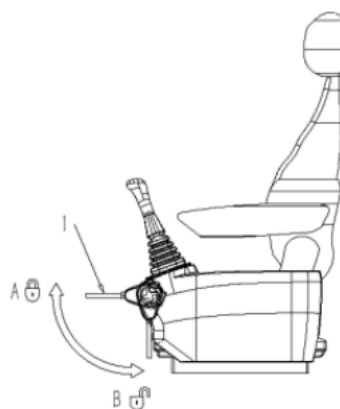

4. Push the locking lever (1) located in the center of the upper part of the front window (upper) toward the right side to unlock it.

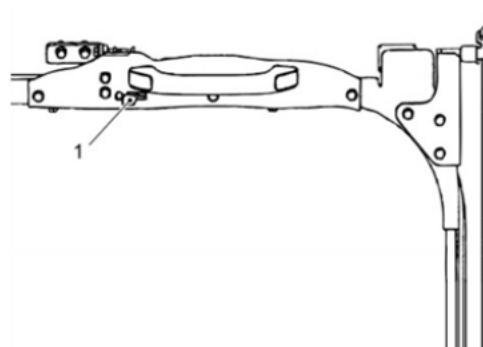

5. If you lift the handles (2) located on the upper and lower parts of the front window (upper) to move it to the very back of the roof, it will automatically lock. However, ensure that it is securely locked.

**When closing the front window**

1. Hold the handles located on the upper and lower parts of the front window (upper) and unlock the locking lever by moving it toward the right.
2. When the front window (upper) is moved back to its original position, it will automatically lock. However, ensure it is securely locked.

**6.5 Removal of front window (lower)**

1. After opening the front window (upper), lift the front window (lower) with both hands and remove it from the window frame.

**6.6 Interior lights**

Operate the switch according to the intended purpose (1)

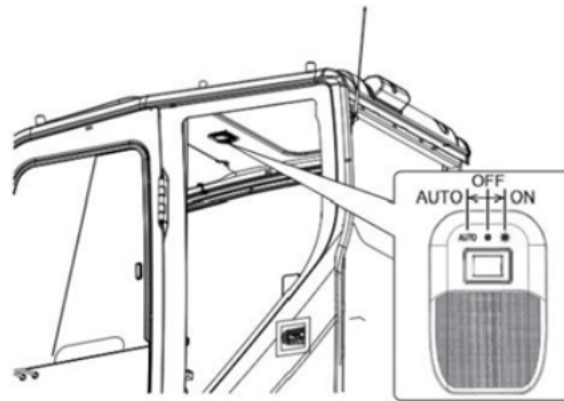

Switch	Contents
AUTO	When you open the door, the interior lights will come on for 25 seconds. After opening the door, the interior lights remain on for 25 seconds even after the door is closed.
OFF	The interior lights do not turn on.
ON	The indicator comes on.

## 7. Emergency exit from the cab

If you are in an emergency and cannot open the driver's door, follow these instructions to get out of the cab.

1. Open the front window to get out.

---

### Additional instructions

About the way to open the front window.

2. In the event that the front window does not open, use the life hammer (1) located at the left rear of the cab to break the front or rear window glass and exit safely.

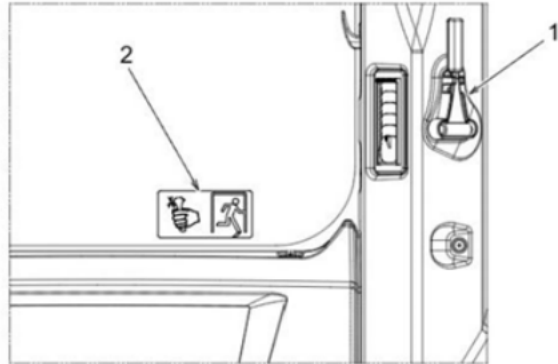

### Attention

When smashing window glass, avoid injury from debris.

### Additional instructions

Labels (2) indicating emergency exits are posted in the rear window.

## 8. Additional accessories

### 8.1 Guard board, and side door (with lock)

#### Attention

When opening the hood, battery cover, side door, etc., be sure to stop the engine first.

Locking mechanisms are provided on the covers of the hood, fuel filler ports, left and right side doors, and cab's door.

Use the start key to open and close. Insert the start key fully to the root and turn it. If the start key is inserted and turned only halfway, it may become bent.

When unlocking and opening the guard board or side door:

1. Insert the start key into the key slot.
2. Turn the start key counterclockwise and pull the door handle to open the door.
3. For doors with a support mechanism, use the support rod to hold the door securely.

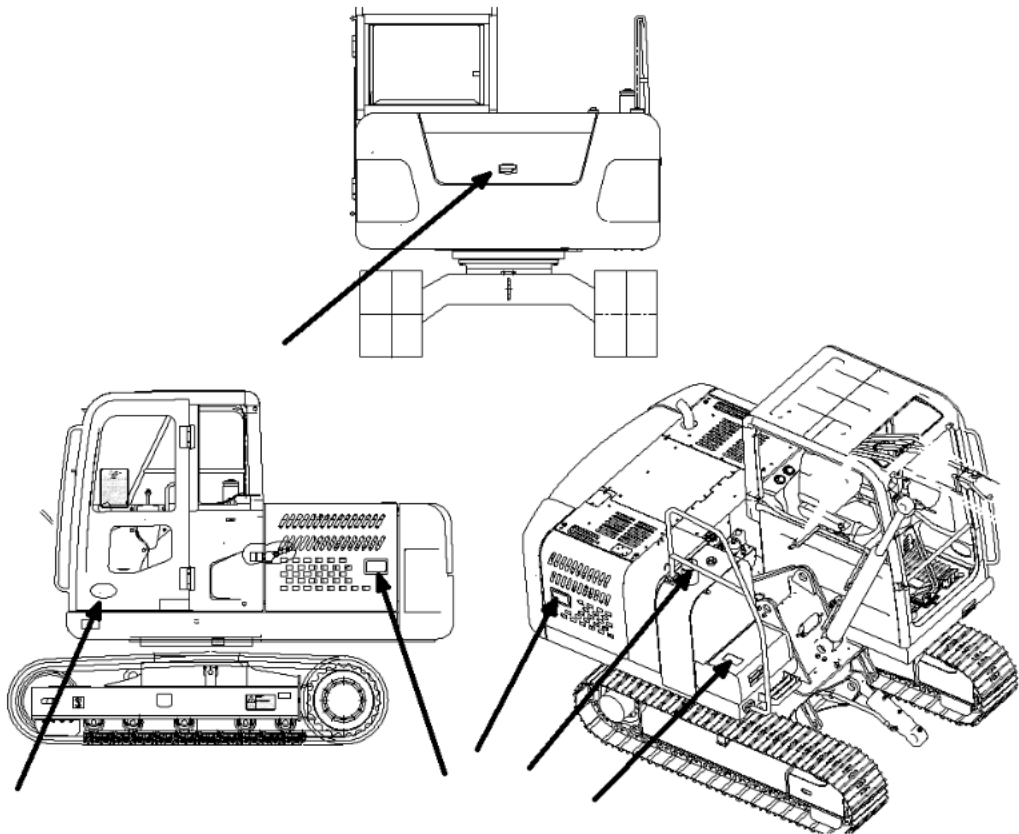

When locking the guard board or side door:

1. If there is a locking lever, return the locking lever to its original position.
2. Close the door.
3. Remove the key by turning it clockwise.





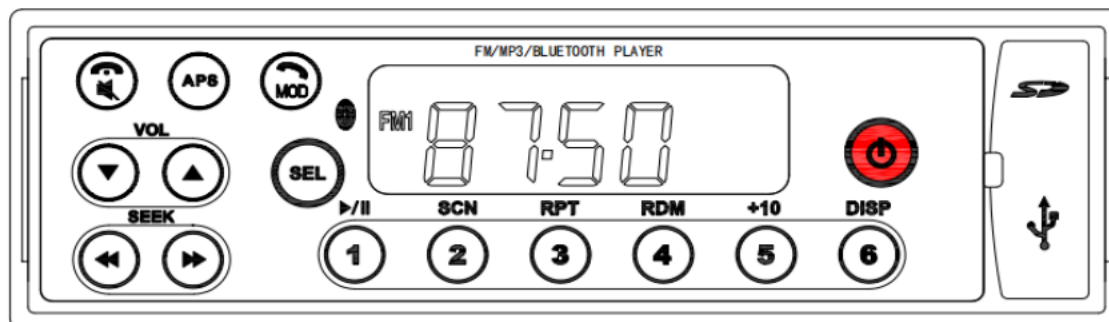



## 9. Description of Bluetooth radio function

### 9.1 Graphic panel



### 9.2 Introduction to panel button functions:

No.	Icon	Function	Functions in different operating modes		
			Radio mode	MP3 mode	Bluetooth mode
1		ON/OFF button	Press this button to turn the power on or off	Press this button to turn the power on or off	Press this button to turn the power on or off
2		Mode switching/answer button	Press this button to switch between MP3/Bluetooth modes	Press this button to switch between radio/Bluetooth modes	Press this button to switch between MP3 and radio modes while in Bluetooth music mode. During Bluetooth calls, use this button to answer incoming calls
3		Band switching button/Automatic channel search	Short press to switch between radio bands. Long press to automatically search for and preset stations	No	No
4		Mute/hangup button	Press this button to mute	Press this button to mute	Press this button to mute in Bluetooth music mode/press this button to hang up in Bluetooth call mode
5		Volume control	Increase or decrease volume	Increase or decrease volume	Increase or decrease volume
6		Station search or next/previous track button	Scan forward or backward for stations	Previous or next track	In Bluetooth music mode, use this button to select the previous

					or next track
7		Setup button	Short press to display the clock. When the clock is displayed, a long press will enter the time setting mode	Short press to display the clock. When the clock is displayed, a long press will enter the time setting mode. A short press will select different sound effects	Short press to display the clock. When the clock is displayed, a long press will enter the time setting mode. A short press will select different sound effects
8		Preset 1/Pause and play button	Short press to select station 1, long press to save the current station as preset 1	Press this button to pause or play	Press this button to pause or play in Bluetooth music mode
9		Preset 2/Browse and play button	Short press to select station 2, long press to save the current station as preset 2	Press this button to start or stop playback browsing	No
10		Preset 3/Replay button	Short press to select station 3, long press to save the current station as preset 3	Press this button to enable or disable the repeat playback of the current track	No
11		Preset 4/Random play button	Short press to select station 4, long press to save the current station as preset 4	Press this button to enable or disable random playback	No
12		Preset 5/Skip ahead by 10 tracks	Short press to select station 5, long press to save the current station as preset 5	Press this button to skip ahead by 10 tracks	No
13		Preset 6/Time and track switching	Short press to select station 6, long press to save the current station as preset 6	Press this button to switch between selecting a track to play and displaying the current playback time	No
14		MP3 music USB flash disk socket	No	MP3 music playback	No

15		MP3 music SD card socket	No	MP3 music playback	No
----	---	-----------------------------	----	-----------------------	----

## Operation

### 1. Daily maintenance checks

Before starting the engine, walk around the machine and check for loose bolts and nuts, leakage of oil, diesel fuel, and cooling water, and confirm the state of the working device, main structure, and hydraulic system, etc.

Check for loose wire connectors and dust buildup in high-temperature areas.

#### A **Warning** About the fire precautions for equipment

Accumulating flammable materials in high-temperature areas such as the engine, muffler, and around the battery, as well as diesel fuel or oil leaks, can cause equipment fires. Conduct a thorough check and repair any malfunctions, or contact us or our agents for assistance.

When slippery items such as grease, hydraulic oil, mud, ice, trash, etc. are attached to steps, armrests, tracks, climbers, and treads, remove them.

- Check the engine for oil, diesel or cooling water leaks. If there is any anomaly, repair it.
- Check for any trash accumulation around the engine and radiator, and ensure to remove any debris.
- Check the hydraulic equipment, hydraulic oil tank, hoses, and fittings for oil leaks, and repair the leaks if there is any anomaly.
- Check around the tread (track, front guide wheel, sprocket) for breakage, wear, loose bolts, oil leakage from rollers, and repair if there is any anomaly.
- Check the working device, main structure, and hydraulic cylinder for anomalies such as cracks, wear, and looseness. Repair as needed if any anomaly is found.
- Check the guard cover, cover plate, tread and armrest for damage and loose bolts, repair any damage and tighten the bolts.
- Check the monitor for any damage and replace it if any anomaly is detected.
- Check the rearview mirrors for any anomalies and replace them if they are broken. Clean the rearview mirror surface and adjust the angle so that the rear can be seen from the driver's seat.
- For machines equipped with rearview and side cameras, ensure that the lenses are free of dirt to maintain clear images on the monitor.
- Check the seat belt and metal connectors for anomalies and replace if damaged.
- Check the grease supply state of the working device. If grease is not visible from the sliding part of the working device, refill it.

#### 1.1 Locking lever

Side doors and hoods, etc. are equipped with locking levers.

Ensure to secure side doors, hood, and similar components with the locking lever when opening them to prevent accidental closure.

#### A **Attention**

Before conducting spot checks and repairs, please confirm that the locking levers on the side doors, hood, and similar components are securely fastened. Unsecured locking levers on side doors, engines, and similar components pose a risk of injury.

#### Rotary locking lever

When opening the side door or hood, insert the locking lever into the locking hole and secure

it.

When closing a side door or hood, remove the locking lever from the locking hole and return it to its original position before securing the closure.

### Sliding locking lever

Open the side door or hood, slide the locking lever into the slot, and secure it in place.

When closing the side door or hood, remove the locking lever from the slot and close it.

## 2 Check before starting the engine

At the beginning of the day, before starting the engine, perform the following checks.

### 2.1 Cooling water level check and refilling

#### A Warning About the use of water tanks

- Normally, do not open the tank cap. Check the cooling water at the reservoir (1) when the engine has cooled down.
- When the engine stops, the cooling water remains at a high temperature and there is residual pressure inside the tank. Opening the cap in this state may cause burns. After the temperature drops, slowly turn the cap to release the pressure.
- If the level in the reservoir frequently drops, contact us and our sales store promptly.

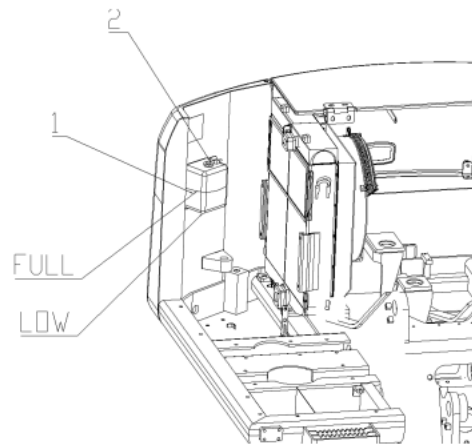

1. Use the key and open the side door on the body.
2. Please confirm that the cooling water is between the FULL (upper limit) and LOW (lower limit) marks of the reservoir (1). If the water level is insufficient, remove the refill port (2) of the reservoir and top it up to the FULL level.

If the reservoir is empty, first check for leaks. Then, check the water level in the tank. If the water level is low, refill the tank and then the reservoir. Afterward, promptly contact the Company and our sales store.

3. After refilling, ensure the cap is tightly secured.
4. Close the side door.

### 2.2 Oil pan level check and refilling

#### A Warning About the temperature after the engine stops

When the engine stops, the parts and oil remain hot, posing a risk of burns. Wait until the temperature drops before starting the operation.

#### Additional instructions

- Check after placing the machine in a horizontal position.

- Check the oil level before starting the engine.
- To check the oil level at the end of operation, do so after stopping the engine for approximately 30 minutes.

1. Use the key and open the hood.
2. Pull out the level gauge (1) and wipe off the oil with a cotton cloth.
3. Re-insert the level gauge (1) to the bottom and then pull it out.

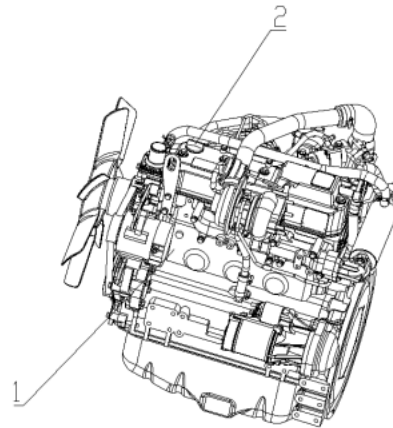

4. As long as the oil level is located between the FULL (upper limit) and ADD (lower limit) of the level gauge (1), it is suitable. When the oil falls below the ADD level, refill the oil from the oil filler cap (2).

Change the oil promptly if it becomes dirty or deteriorated, regardless of whether regular replacements are scheduled. For the oil to be used, refer to "Recommended Oil and Replacement Capacity".

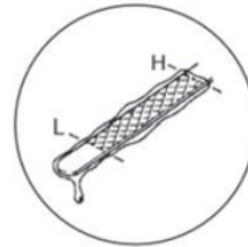

5. When the oil exceeds the FULL level, loosen the release plug (3), drain the excess oil, and check the oil level again.
6. Ensure the oil level is correct and properly insert the level gauge (1).
7. Close the hood.

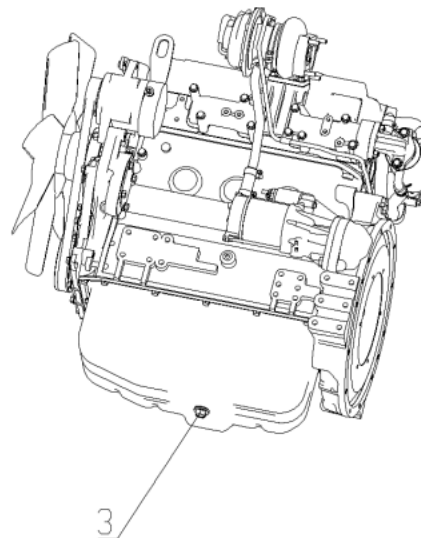

## 2.3 Fuel level check and refilling

### A Warning About the fuel refilling

- Use only diesel fuel and avoid any other type of fuel. Ensure you don't get the wrong type of fuel before refilling.
- Be sure to turn off the engine when refueling.

- Avoid spilling fuel when refilling, as this may result in a fire. Wipe up any spilled fuel.

#### **A Attention**

When getting on and off the machine, use the treads and armrests and avoid tipping or falling.

#### **Additional instructions**

- Take care not to overfill the tank (top of tank). Otherwise the rising temperature of the outside air will cause the fuel to expand and may overflow from the tank.
- Be sure to use diesel fuel that meets the standards of each country. To achieve optimal fuel consumption and emission characteristics, this machine's engine uses an electronically controlled high-pressure fuel injection unit.

The unit demands high precision and lubricity, so using low-viscosity fuels with poor lubricity may greatly reduce its durability.

1. Check the fuel level on the display.

With the starter key switch set to "ON", the fuel gauge is displayed. The pointer indicates point E when the fuel level is low.

2. Stop the engine when refilling fuel.

3. Lift from the right front of the machine to refill the fuel.

4. If the fuel filler has a rubber cap, remove it first and then turn the filler cap to open it.

5. Refill the fuel using a fliter mesh placed in the fuel filler.

When debris or other objects adhere to the screen, remove the screen, clean it with diesel fuel or an air gun, and then replace it in the fuel filler.

6. After refilling, securely fasten the filler cap. Additionally, install the rubber cap in the direction of the filler cap.

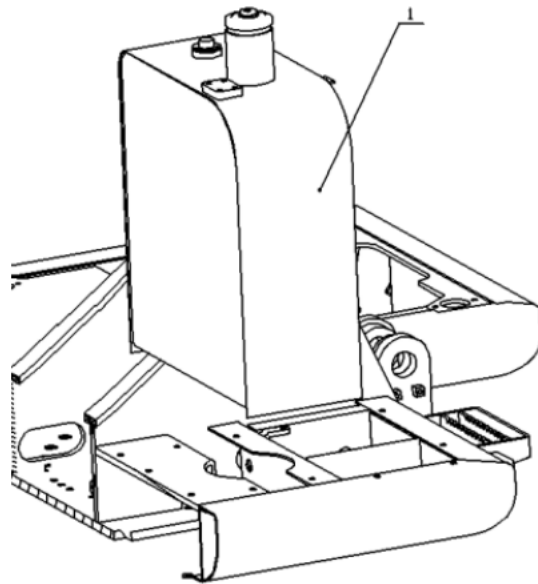

### **2.4 Fuel coarse filter drain**

#### **A Warning**

If a foreign object is attached to the mounting part of the drain plug, the O-ring may be damaged. If the O-ring is damaged, it will cause a fuel leak and a fire.

### **2.5 Checking the oil level in the working tank**

#### **A Warning About the pressure in the working tank**

Pressurized high temperatures in the working tank are hazardous.

To remove the fuel filler, stop the engine and push the valve (1) to relieve the pressure in the working tank.

The working tank is located on the right side.

1. Move the machine to a sturdy and level place.
2. Retract the arm cylinder and bucket cylinder until the bucket and shovel (if installed) are in contact with the ground.
3. Please stop the engine and place the locking lever in the locked position.
4. Check the oil level with the level gauge 19 on the side of the working oil tank. As long as the oil volume is within the H-L range, it is appropriate.

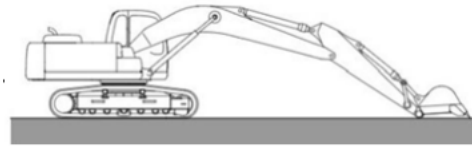

The height of the level gauge varies with the oil temperature. Refer to the following criteria to check it.

- Pre-operation: Near L level (oil temperature 10~30°C)
- During normal operation: Near H level (oil temperature 50~80°C)

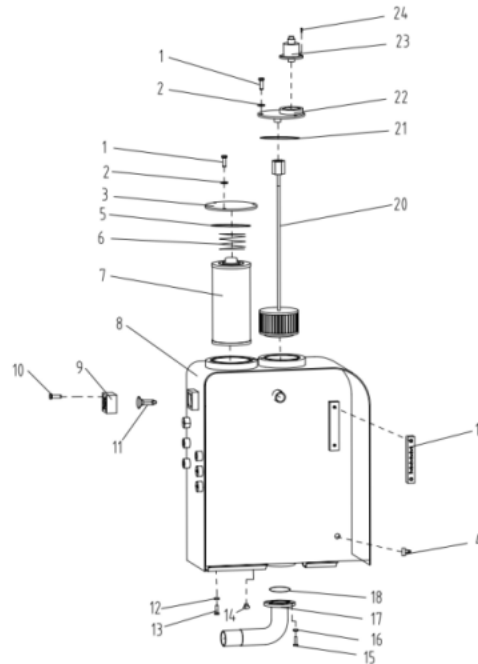

### Additional instructions

Do not refill beyond the H level.

If the working tank is filled to full capacity, there is a risk of damaging the tank or machine, and working oil may spray out.

### 2.6 Check of fan belt and air conditioner belt

#### A Warning About belt check and maintenance

Ensure the engine is turned off before performing any checks or maintenance.

If check or maintenance is performed while the engine is running, you risk getting caught in the rotating parts of belts, fans, etc., which can result in serious personal injury.

#### A Attention

During checking, if you find localized cracks or breaks in the belt, or significant slipping that prevents adjustment within the specified range, replace the belt with a new one. Avoid applying oil to the belt, as it will cause slippage and shorten its lifespan.

### Additional instructions

- After replacing a new belt, let the engine idle for 3 to 5 minutes to accommodate the initial belt fit. Then, reconfirm and adjust the belt tension as needed.
- The new belt should run for approximately 2 hours to fully release its initial elongation.
- When replacing a set of 2 belts, ensure both are replaced with new ones

The engine of this machine is equipped with an alternator, a fan, and a belt for the air

conditioner.

To maintain maximum engine performance, longevity, check these belts for wear and damage, and check the belt tension and adjust it properly.

To check the belt tension, press the center of the belt with your thumb. If the deflection falls within the range specified in the following table, it is considered normal.

Belt	New belt tensioning mm	During checking mm	Push force N
Fans, alternators	5~8	7~10	98
Air conditioner belt	2.2	2.2	• 27~34※ New belt tensioning • 13~17※ During checking

## 2.7 Driver's seat adjustment

### A Warning About the driver's seat adjustment

- Adjust the settings before operation or when handing over to a new driver.
- When adjusting the driver's seat, take care to avoid pinching your hand between the handle and the seat bracket.

Sit in the driver's seat and rest your back against the seat back. Adjust the driver's seat so that you can comfortably operate the operating levers, pedals, and switches.



## 2.8 About the mirror adjustment

### A Warning About the mirror adjustment

Be sure to adjust the mirrors before operation.

If the mirrors are not adjusted properly, it may obstruct your view and lead to a serious fatal accident.

### A Attention

Use only plain mirrors.

If mirrors are installed in areas other than those specified, such as the armrests at the upper and lower cab openings, they may cause the armrests to become weaker, damaged or detached.

Adjust the left side mirror (1) to the position that offers the clearest view of the center area while seated in the driver's seat.

- (1) Mirror
- (2) Seat
- (3) Display

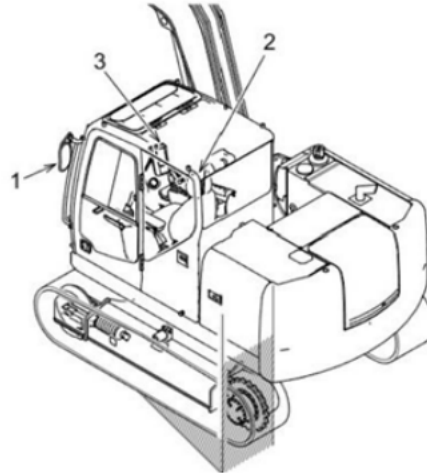

**Mirror A (left side of cab)**

When assembling a mirror, adjust the lens so that a person (or an object 1.2m high and 30cm in diameter) at the left rear end of the machine is visible from the driver's seat.

- Assemble the mirror in the position shown.
- When mounting the mirror, avoid interference between the mirror and the mounting bracket (1).
- If the mirror movement is tight, loosen the mirror nut (2) and adjust it.
- Adjust the mirror so that it illuminates the side of the body.

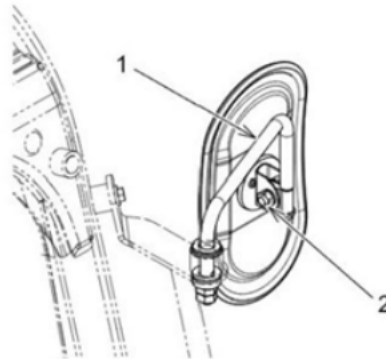

**2.9 Display checking of multi-function displays**

Before starting, confirm the display state of the multi-function display and the multi-function display of the switch panel according to the following points.

**A Attention**

When a warning is displayed on the multi-function display, have it checked by the Company or our sales store.

1. Please confirm that the lifting hydraulic locking lever is in the "locked position".
2. Please confirm that each operating lever is in the "neutral position".
3. Place the key start switch in the "ON" position.
4. Please confirm that the alarm display appears on the multi-function display.

**2.10 Confirmation of operation light illumination**

When the start key switch is in the "ON" position, the boom and right front operating light will illuminate if the operating light switch is pressed. If the light does not turn on, the bulb is considered to be burned out or disconnected, so have it repaired by the Company or our sales store.

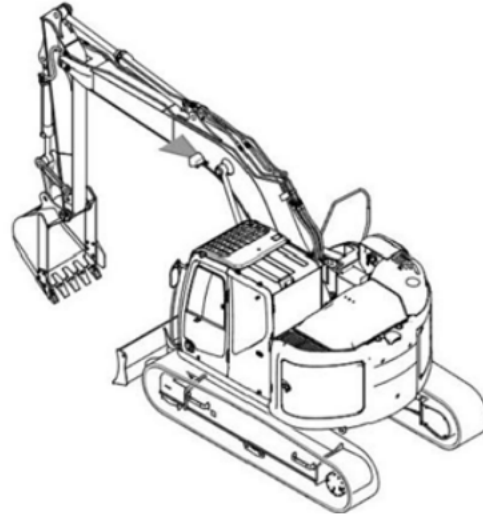

### **2.11 Check the air filter intake**

- Check for buildup of mud, leaves, or snow around the suction port of the air filter.
- If there is any accumulation of snow, etc., sweep it away.
- When washing your vehicle with high-pressure water, ensure that water does not enter the air filter's suction port.

## **3. Engine start**

### **A Warning At engine startup**

Please confirm that the machine is not surrounded by people or obstacles, sound the horn, and then start it.

### **Additional instructions**

- Do not allow the starter to rotate continuously for more than 15 seconds. When starting fails, return the start key to the OFF position for an interval of 30 seconds or more, then start again. Neglecting this operation may lead to starter failure and battery discharge.
- When an alarm appears on the display during engine startup, immediately stop the engine and investigate the cause. If necessary, perform repairs.
- Before restarting the engine after engaging the automatic idle stop, make sure the start key switch is in the OFF position and the throttle adjustment knob is set to low idle. Note that the engine cannot be restarted until the buzzer stops after the engine is turned off.

### 3.1 Start-up at room temperature

1. Please confirm that the lifting locking lever (1) is in the "locked position".

A: Locked position

B: Unlock position

2. Please confirm that each operating lever is in the "neutral position".

3. Place the throttle adjustment knob in the low idle position.

4. Place the key of the start key switch in the "ON" position and check the operation on the display.

5. Turn the start key switch to the "START" position to start the engine.

6. After starting, quickly let go from the key. The key automatically returns to the "ON" position.

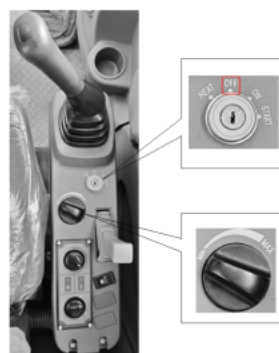
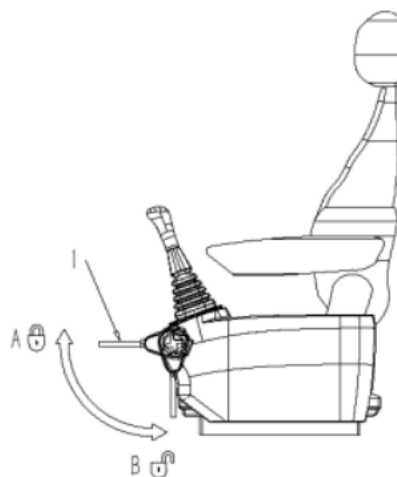

### 3.2 Cold start

When it's cold, oil viscosity increases and battery performance decreases, so engine starting can become difficult.

1. Please confirm that the lifting locking lever (1) is in the "locked position".

A: Locked position

B: Unlock position

2. Please confirm that each operating lever is in the "neutral position".

3. Place the throttle adjustment knob in the low idle position.

4. Turn the start key switch to the "ON" position and hold it there.

Check the engine water temperature and automatically preheat the glow plug if the cooling water temperature is below 10°C (50°F).

5. Please confirm the operation on the

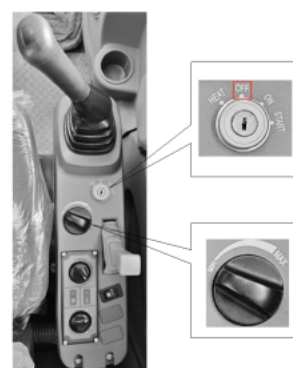
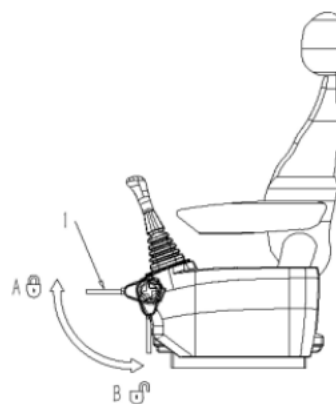

multi-function display.

6. When warm-up is complete (within 5 seconds), turn the key of the start key switch to the "START" position and start the engine.

7. After starting, quickly let go from the key. The key automatically returns to the "ON" position.

### **3.3 Use the battery cable to start**

#### **A Warning About using the battery cable to start**

- Flammable gas (hydrogen) is generated from the battery. Sparks near the battery may cause ignition or explosion, so keep away from sources of ignition.
- Don't let the functioning vehicle come into contact with the faulty vehicle to save the negative cable.
- Use goggles and rubber gloves when starting with a battery cable.
- Never allow the (+) terminal to come into contact with the (-) terminal when connecting cables.
- When connecting the battery cable, do not confuse the positive (+) and negative (-) terminals. Although the battery wire on the negative (-) side is the last to be connected to the upper rotating body of the faulty vehicle, sparking may occur at this point. Connect it as far away from the battery as possible.
- Avoid starting the engine with another power source if the battery fluid has frozen.
- Note that there is a danger of the battery exploding if the wrong battery cable is connected.
- This vehicle is equipped with a 12-volt starting system. Use a 12-volt product for the auxiliary battery as well. The electrical system may be damaged if started at high voltage using a welding machine or similar equipment.

#### **A Attention**

- For functioning vehicles, use a battery with the same capacity as the faulty vehicle.
  - Use battery cables and clamps that are appropriate for the size of the battery.
  - Check for breakage and corrosion on the battery cable and clamps.
  - Connect the cable clamps securely.
  - Please confirm that the lifting hydraulic locking lever is in the locked position.
  - Please confirm that each operating lever is in the neutral position.
  - Until the cable connection is completed, place the start key switch of both normal and faulty machines at OFF. When the power is turned on, the action may pose a danger.
1. Lower the functioning vehicle's working device to the ground, set all levers to the neutral position, and place the lifting hydraulic locking lever in the "locked position".

2. Turn the start key switch to "OFF" on both the functioning and faulty vehicles.

3. Remove the terminal cover of the battery and connect the clamp of the battery wire (red) to the positive (+) terminal of the battery of the faulty vehicle.

4. Attach the red battery cable clamp to the positive (+) terminal of the battery in the functioning vehicle.

5. Attach the black battery cable clamp to the positive (-) terminal of the battery in the functioning vehicle.

6. Finally, connect the (-) clamp of the battery cable (black) to the upper rotating body frame of the faulty vehicle.

7. Start the engine of your functioning vehicle and let it run at high speed for approximately 10 minutes. Partially charge the faulty vehicle's batteries.

8. Please start the engine of the defective machine.

9. Immediately after starting the engine of the defective machine, remove the battery cable by following the reverse of the connection procedure.

10. Finally, investigate the cause of the malfunctioning starter/charging system of the faulty vehicle and repair it.

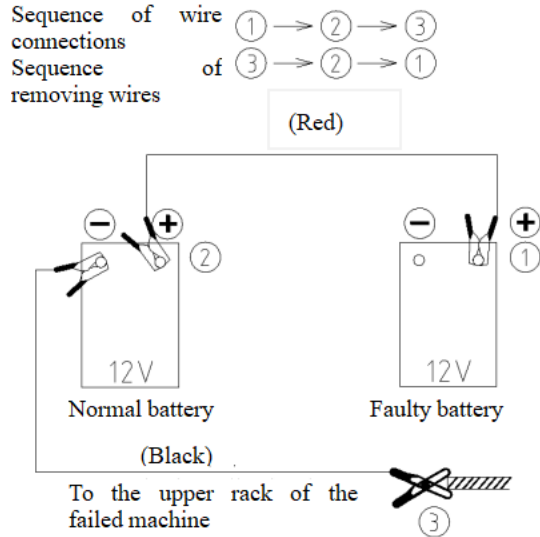

#### 4. Engine with the stop

1. Allow the bucket to touch the ground when stopping the engine.
2. Raise and lower the lifting hydraulic locking lever and place it in the "locked position".
3. Please turn the throttle adjustment knob to the low idle position.
4. Stop the engine by placing the start key in "OFF".
5. Remove the start key for safekeeping.

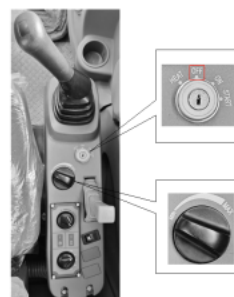

#### 5. Engine check after startup

Check and confirm before operating the machine after starting the engine. If there is any anomaly, contact our sales store.

##### 5.1 Lifting hydraulic locking lever

Please confirm that the locking function of the lifting hydraulic locking lever is functioning properly.

1. Place the lifting hydraulic locking lever in the locked position.
2. When the lifting hydraulic locking lever is in the locked position, ensure that the working device, rotation and traveling movements are not effective.

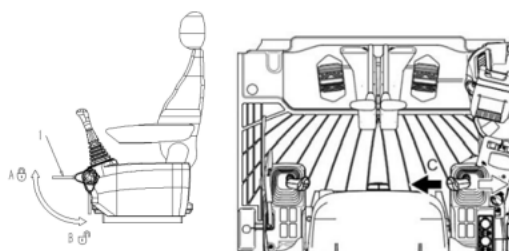

##### 5.2 Action confirmation of engine and multi-function display

1. Look around the engine and check for oil and water leaks.
2. Please confirm that the alarm displays for battery charging and oil pressure have disappeared, and ensure that the gauge pointers for the engine water temperature gauge (1) and fuel quantity indicator gauge (2) are appropriate.



## **A Attention**

When an alarm appears on the multi-function display, stop the engine quickly and investigate the cause.

Check if the engine's exhaust sound, exhaust color, and vibrations are normal.

## **Important**

Method of identifying the color of exhaust (after warming up, when unloaded)

Colorless or light blue: Good (full combustion)

Black: Bad (insufficient combustion)

White: Bad (oil leaking both upwards and downwards)

It may look white in the winter when temperatures are low.

## **6. Warm-up**

### **A Warning About warm-up**

- The normal temperature of the working oil of this machine is about 50°C. If strenuous operation is performed when the oil temperature is below 25°C, major malfunctions of hydraulic equipment and other components may occur. Before starting operation, heat the working oil to 25°C or more.
- If the working device is started without sufficient warm-up, it will respond slowly to the operating lever and may sometimes move beyond the driver's intention. Therefore, ensure a proper warm-up is performed. Especially when the weather is cold, please perform sufficient warm-up operation.

## **Important**

For warm-up, turn the automatic idle stop switch to "OFF".

### **Additional instructions**

For instructions on starting the engine using the automatic warm-up system, refer to "User Menu Settings".

### **6.1 Engine warm-up**

#### **Additional instructions**

Avoid slamming the accelerator, as it may cause engine problems and malfunctions.

1. Turn the throttle adjustment knob (1) to the middle position between low idle and full speed rotation, so that the engine rotates at medium speed and runs without load for about 5 minutes.
2. When the pointer (2) of the engine water temperature gauge reaches the white range, the engine warm-up is complete.

## 6.2 Warm-up of working oil

Warm-up of the hydraulic oil should not be done until after the warm-up of the engine has been completed.

1. Push down the lifting locking lever (1) toward the front to place it in the "unlocked position".
2. Lift the boom to a height where the bucket can move freely.
3. Slowly operate the right operating lever toward the digging side of the bucket so that it is in the end-of-travel position, releasing the hydraulic oil for approximately 2 minutes time.
4. Then, the cylinders are made to reciprocate slowly several times.
5. If preheating is not sufficient, perform the release operation to the digging side (C) of the bucket for another 2 minutes, and after preheating, slowly move each cylinder back and forth several times to circulate hot hydraulic oil through all operating circuits.
6. Slowly perform rotating and traveling motions to circulate hot hydraulic oil.

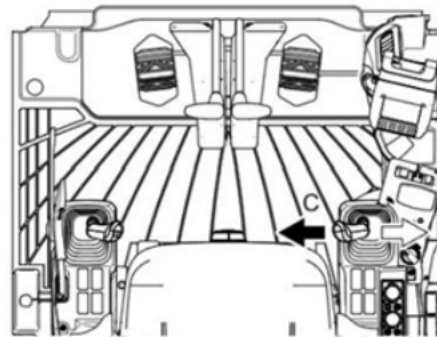
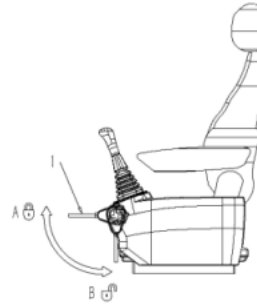

## 7. Automatic idle stop function

### A Attention

The machine features an automatic idle stop function to minimize fuel consumption and reduce exhaust emissions from unnecessary engine idling.

- With the automatic idle stop switch at ON, if the engine starts, it will stop after a certain period once the lifting hydraulic locking lever is raised.
- Before restarting the engine after engaging the automatic idle stop, make sure the start key switch is in the OFF position and the throttle adjustment knob is set to low idle. Note that the engine cannot be restarted until the buzzer stops after the engine is turned off.
- To warm up the engine, use the air conditioner, or continuously operate the operating light while the lifting hydraulic locking lever is in the "locked position" (A), make sure to turn off the automatic idling stop function. These functions also stop when the automatic idle stop function is "ON", thus stopping the engine.
- When leaving the driver's seat, be sure to turn the start key switch to OFF.
- The automatic idle stop function remains inoperative, regardless of its "ON/OFF" setting.

when an abnormal alarm is displayed for "Engine water temperature" or "Cooling water level", or when the automatic warm-up is active.

- Do not use the automatic idle stop mode when performing lifting operations.

It is usually "OFF". If the automatic idle stop function is set, the engine will stop automatically after the lifting locking lever (1) remains in the "locked position" (A) for a certain period. This reduces fuel consumption and suppresses the emission of exhaust.

- Refer to "Setting the Automatic Idle Stop" for instructions on setting the automatic idle stop function.
- The engine stop time is initially set to 60 seconds.

For changes in the setup time, contact our sales store.

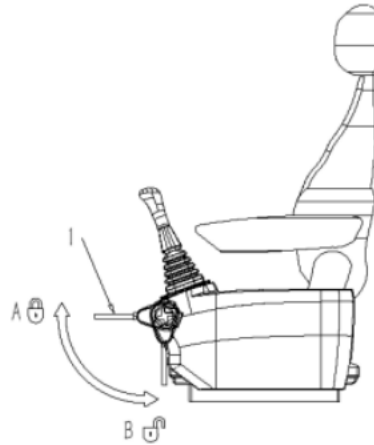

#### **Additional instructions**

- After placing the lifting hydraulic locking lever in the "locked position" (A), a deceleration rotation occurs after an interval of approximately 4 seconds.
- The buzzer sounds for 5 seconds before the engine stops.

#### **7.1 Restart after automatic idle stop**

##### **A Attention**

When leaving the driver's seat, be sure to turn the start key switch to "OFF".

1. Please confirm the buzzer has stopped.
2. Place the throttle adjustment knob in the low idle position.
3. Turn the key of the start key switch back to "OFF" first, and then restart it.

## **8. Operation mode selection**

#### **Additional instructions**

Always start the engine operation in "Turtle" mode.

### "Turtle" mode:

This mode is designed for standard excavation and loading operations, offering low fuel consumption while maintaining a balance with the workload.

### "Rabbit" mode:

This mode provides rapid performance, ideal for heavy-duty excavation tasks, prioritizing work intensity and high mobility

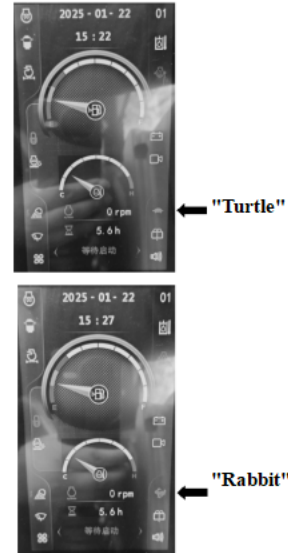

## 9. Switching of working device modes

You can toggle between "Turtle" mode and "Rabbit" mode by touching the respective symbols on the display. When the "Turtle" logo appears, it signifies the machine is in "Turtle" mode, and when the "Rabbit" logo appears, it signifies that it is in "Rabbit" mode.

### A Attention

- When installing a hydraulic breaker hammer or hydraulic shear, ensure that the mode selection of the touch Turtle-Rabbit sign is appropriate by using the working device mode switch and the multi-function display.
- Ensure the working device touches the ground first to confirm safety when changing its mode. Particularly, there is a risk of gripped loads or similar items falling if the hydraulic shear operation is switched to breaker hammer operation.
- If the symbols "bucket," "hydraulic shear," or "breaker hammer" of the working device mode are flashing, the working device mode is not suitable.

## 10. Operation and control of the machine

The following operating points constitute the fundamental skills that an operator must master. Carefully study these basic matters. Enhanced familiarity with the machine's performance and structure will further refine operating techniques.

### 10.1 Precautions for the operation and control of the machine

#### A Warning About the operation and control

- Before starting, please confirm that the area around the machine is safe, sound the horn.
- Ensure all personnel are clear from the machine's vicinity.
- When operating the lever during automatic speed control, the engine speed will increase sharply. Exercise caution.

#### A Attention

- The display does not guarantee the machine state. Do not rely solely on the display for routine checks; instead, follow the instruction manual carefully.
- If you find any anomaly in the machine during operation, stop the operation

immediately and take the correct disposal.

- Do not operate the machine until the problem area has been repaired. Continuing operation in a faulty state could result in a major disaster.

### Front, rear, left, and right sides of the machine

This manual defines the front, rear, left, and right of the machine according to the machine's forward direction (front) as viewed from the driver's seat, with the traveling motor located at the rear.

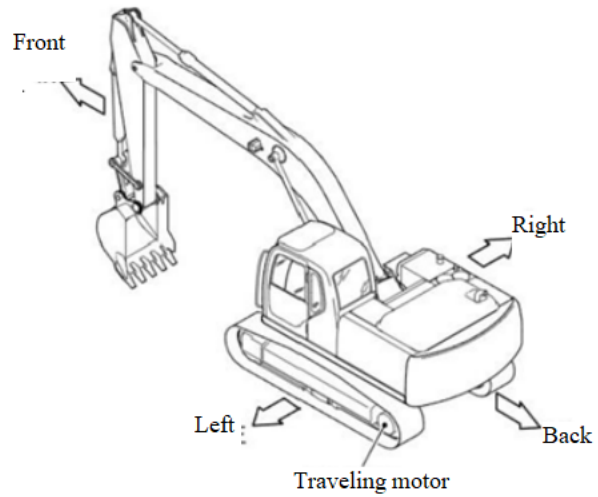

## 10.2 Traveling essentials

### A Warning About traveling speed

- Check the position of the traveling motor when traveling. When the traveling motor is positioned at the front, the travel lever functions in the opposite direction relative to the machine. Formal traveling operation occurs when the traveling motor is positioned at the rear of the machine, and the front guide wheel is situated at the front.
- To alert site operators, sound your horn.

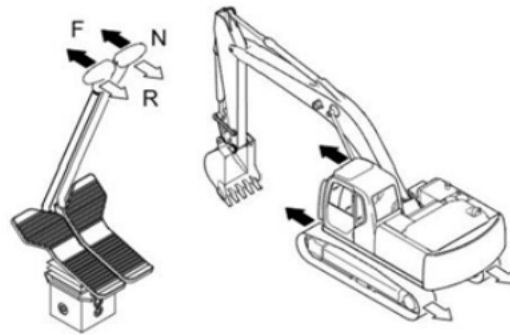

Before traveling, ensure that the lifting hydraulic locking lever is in the "unlocked position" and the bucket is placed 30 to 40 cm above the ground.

F: Forward

N: Neutral (stop)

R: Backward

### Traveling forward and backward

- Simultaneously operate the left and right travel levers either forward (towards the front) or backward (towards the rear).

The traveling speed can be adjusted by moving the handle either forward or backward.

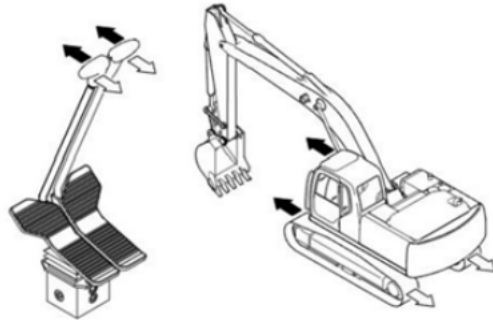

### Unilateral turning

This operation involves driving only one side of the track to change direction.

- Operate one of the 2 travel levers.

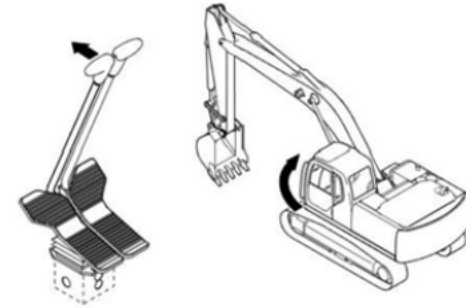

### Steering

This operation changes direction on the spot by driving the left and right tracks in opposite directions.

- Operate one travel lever forward and the other backward simultaneously.

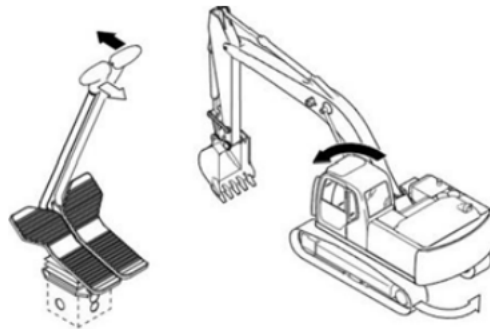

### Stop

#### A Warning About stop

Avoid emergency stops and leave as much room in the stop as possible.

Place the left and right travel levers (1) in the neutral position (N). The machine stops.

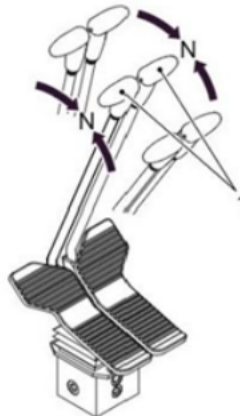

### 10.3 Switch for selecting between Speed 1 (low speed) and Speed 2 (high speed)

#### A Warning About loading and unloading

When loading onto or unloading from a flatbed truck, always operate the machine at low speed (Speed 1). Avoid switching the travel switch during this process.

The traveling speed toggle switch is located on the multi-function display and on the switch panel of the switch panel. Every time you start the engine, it will automatically be set to Speed 1 (turtle). Pressing the switch on the multi-function display and switch panel will change the travel mode to Speed 2. The rabbit icon will appear on the multi-function display

to indicate this.

Use this mode when navigating uneven, loose, sloping, or narrow terrains, or when significant traction is necessary. 

Use this mode when moving on flat and firm ground. 

#### 10.4 Driving in water and on soft ground

##### Important

To prevent water and grit from adhering to the rotating bearing, pinion, and rotary joint, exercise caution. If water or grit does adhere to the rotary bearing, continued use could lead to abnormal wear. Apply grease.

- When the riverbed is flat and the current is gentle, the machine can travel through water at a depth (A) that is below the center of the upper support wheel.
- When crossing a river, check the bottom of the river with a bucket, etc., and cross the river carefully. Never enter water deeper than (A).
- On soft ground, the body may sink slightly. Therefore, continuously monitor the track assembly and water depth.
- After driving in salt water, wash your vehicle carefully to remove the salt.
- Use a grease gun to thoroughly lubricate parts that have been immersed in water for an extended period, until the old grease is expelled.

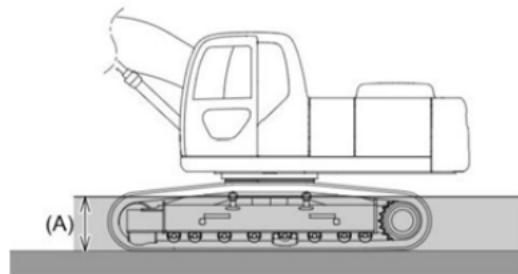

#### 10.5 Essentials of getting off soft ground

Avoid driving on soft ground as much as possible. Avoid getting bogged down while running. If you happen to get stuck in a quagmire, follow these steps to get out.

##### Sinking on one side in soft ground

- When one side is sunk, use the bottom of the bucket to push the ground, lift the track plate on the sunk side, pad it with columns and

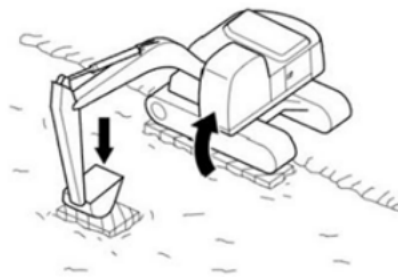

wood, and then free the machine.

### **Additional instructions**

When lifting the vehicle with the boom and arm, use the bottom of the bucket to push against the ground, rather than the bucket teeth.

### **Sinking on both side in soft ground**

#### **A Attention**

Operate from the driver's seat and keep people away from the perimeter of the machine.

1. When both tracks sink and slip, making movement impossible, follow these steps: pad columns or wood so the working device touches the ground in front, bend the arm as you would for digging, move the travel lever forward, and pull out the machine.

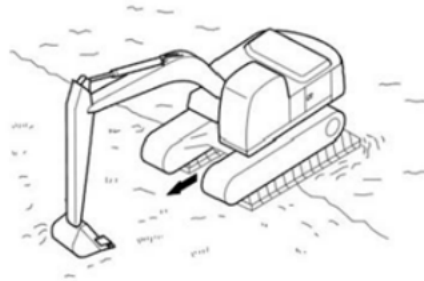

2. If the track assembly becomes clogged with dirt, sand, or other debris while traveling on soft ground and the track is too taut to move, raise the boom or arm and allow the track to hang freely. This will help to shake off and remove the dirt, sand, and debris.

With the tracks suspended, alternately move forward and backward to shake off entrapped stones, sand, and soil.

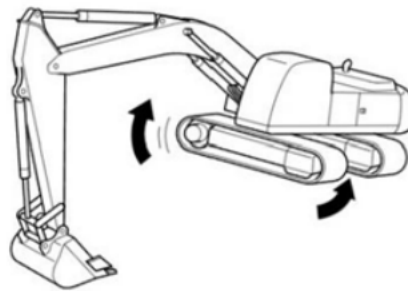

### **10.6 Operation of rotatory and working devices**

The following are the operating instructions for the standard working device. For machines fitted with special working devices, also read the instruction manual for the special working device. Operating instructions in ISO mode.

#### **A Warning About the use of this machine**

Before operating this machine, thoroughly read the safety precautions outlined in this manual.

#### **A Warning Note the interference of the front-end working device**

Depending on the combination of the type of working device and the specifications of the optional parts on the side of the body, the front-end working device may interfere with the cab and other parts of the machine during operation. Please confirm whether there is no interference before operation.

### Boom operation

When operating the boom, move the right operating lever forward and backward for operation. The speed of the boom is determined by the amount of movement of the operating lever.

- A: Pull the right operating lever backward to raise the boom.
- B: Push the right operating lever forward to lower the boom.
- Return the right operating lever to the neutral (center) position and stop the boom.

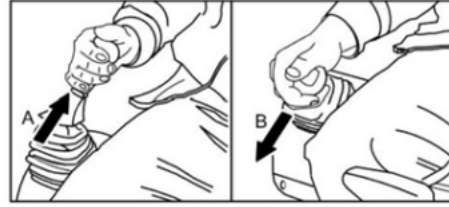

### Arm operation

When operating the arm, move the left operating lever forward and backward for operation. The speed of the arm is determined by the amount of movement of the operating lever.

- A: Pull back on the left operating lever and move the arm closer to the cab side. (Arm recovery)
- B: Push the left operating lever forward and leave the arm forward (arm extended).
- Return the left operating lever to the neutral (center) position and stop the arm.

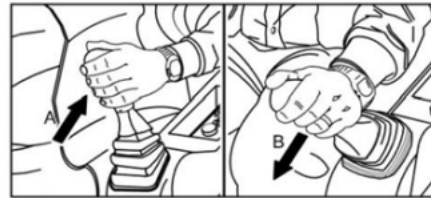

### Bucket operation

To operate the bucket, move the right operating lever to the left or right. The speed of the bucket is determined by the amount of movement of the operating lever.

- A: Move the right operating lever to the left and the bucket moves to the digging side.
- B: Move the right operating lever to the right and the bucket moves to the extended side.
- Put the right operating lever back to the neutral (center) position and the bucket stops.



## A **Warning Preventing rotational hazards**

Please confirm there are no people or obstacles within the rotation range and around the machine. Give a warning by means of a horn or hand signal before running the machine.

For rotary operation, move the left operating lever to the left and right. The speed of rotation is determined by the amount of movement of the operating lever.

- A: Move the left operating lever to the left and the machine rotates to the left.
- B: Move the left operating lever to the right and the machine rotates to the right.
- Put the left operating lever back to the neutral (center) position and the rotation stops.



## 11. Essentials for machine operation

### 11.1 Digging

Digging primarily utilizes the recovery force of the arm and, as needed, the digging force of the bucket.

- When strong digging force is required, control the angle (C) between the boom and the arm roughly in the range of 90 to 110° and dig slowly.

When lowering the boom, do not operate it vigorously. An emergency stop during the boom's descent can create a significant impact on the machine, negatively affecting all its parts.

- Align the bucket teeth in the digging direction (A), keep the bucket shallow (B), and then use the boom and bucket to dig. This reduces digging resistance and minimizes wear on the bucket teeth.
- When the gravel does not fall easily, place the bucket in the extended position, operate the operating lever and move the bucket 2 to 3 times.
- Avoid repeatedly extending and retracting the bucket cylinder to drop gravel when the boom cylinder and the arm cylinder are at their shortest lengths.

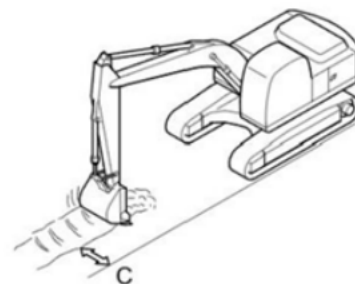
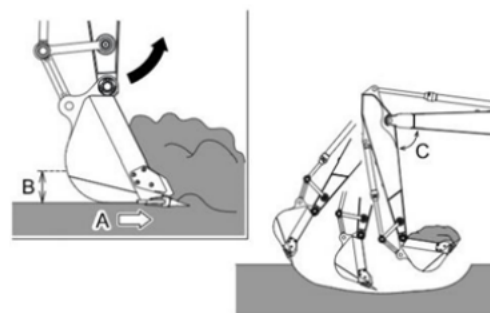

- To dig a wide trench, start by excavating the sides, and then dig the center last. Using a bucket designed for trench digging and positioning the tracks parallel to the ditch (C) to be excavated makes the operation more efficient.

### 11.2 Loading operation

When operating in areas with limited rotation angle, position the dump truck so that the operator has a clear line of sight for loading.

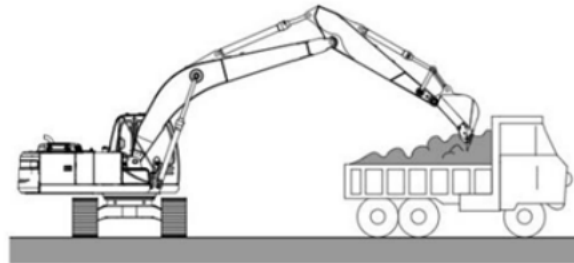

## 12 Machine Parking

1. Move the machine to a level and firm place.
2. Please let the bucket touch the ground.  
If a dozer blade is installed, allow the dozer blade to touch the ground.
3. Be sure to set the automatic throttle switch to "OFF".



4. Be sure to place the lifting locking lever (1) in the "locked position (A)".  
If it is not placed in the locked position, the machine may move against the driver's intent when the lever is touched, which is very dangerous.
5. Please turn the throttle adjustment knob to the low idle position.
6. Please place the start switch in the OFF position, turn off the engine, and remove the key.

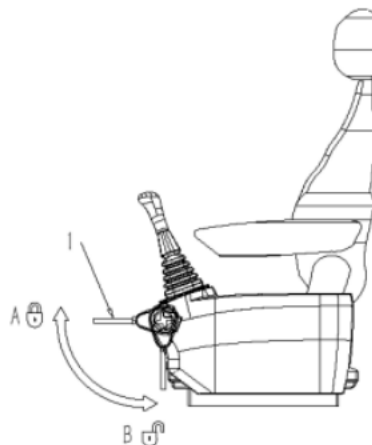

When leaving the machine, please close the windows, driver's door, all doors and cover plates, and then lock them.

### 12.1 Park on a slope

When you have to stop on a slope, follow the following steps.

1. Please ensure that the front of the machine body faces the downhill side.
2. Please hold the bucket against the ground.

If a dozer blade is installed, allow the dozer blade to touch the ground.

3. Be sure to set the automatic throttle switch to "OFF".

4. Be sure to place the lifting locking lever (1) in the "locked position (A)".

If it is not placed in the locked position, the machine may move against the driver's intent when the lever is touched, which is very dangerous.

5. Please turn the throttle adjustment knob to the low idle position.

6. Please place the start switch in the OFF position, turn off the engine, and remove the key.

When leaving the machine, please close the windows, driver's door, all doors and cover plates, and lock them.

7. To prevent the machine from moving, block the tracks with a blocking object.

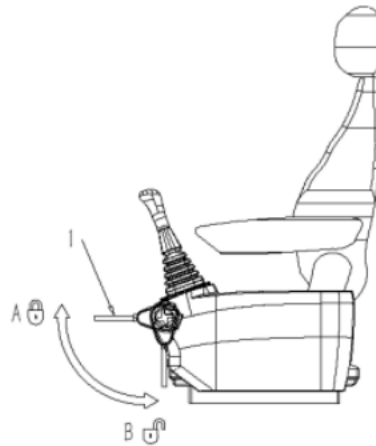
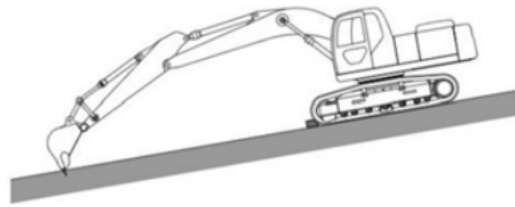

## 13 Post-operation checks and confirmations

Check the engine cooling water temperature, oil pressure, and fuel remaining on the display.

- If there is an engine cooling water temperature, oil pressure alarm display, ensure a safe place to stop the engine immediately, the
- Check for oil leaks, water leaks, working devices, outfits, and track assemblies. In case of any leaks or anomalies,
- fill the fuel tank to its full capacity. At the end of the day's operations, ensure to refill the fuel tank. However, take care not to overfill the tank (top of tank). Otherwise the rising temperature of the outside air will cause the fuel to expand and may overflow from the tank.
- When grease, hydraulic oil, dirt, debris, or other slippery substances accumulate on the treads, armrests, tracks, ladders, or scaffolding, remove them.

## 14 Use under special conditions

### 14.1 Use in cold weather

#### A Attention

- If the temperature drops, reduced oil fluidity may cause difficulties in starting the engine, and freezing cooling water can lead to breakage of water tanks and other components.
- Prolonged idling at low RPM can cause the DPF to become clogged.

### Fuel and oil

Use high-quality, low-viscosity fuel and oil for each unit. Refer to Chapter 4 "Recommended Oil Viscosity and Replacement Capacity" for the appropriate viscosity.

### Cooling water

When operating or storing the machine in cold areas, adjust the additive ratio in the system according to the predicted minimum outside air temperature.

If the cooling water freezes, the tank, block, cylinder head, etc. may break. When the machine is shipped from the factory, it is filled with long-life cooling water to prevent the engine cooling system from rusting and freezing.

When performing operation or storage in cold weather, check the concentration of cooling water from time to time and maintain the proper concentration. Refer to Chapter 4, "Recommended Oil Viscosity and Replacement Capacity" for cooling water concentration.

### Battery

Lower temperatures may result in a loss of capacity and icing of the battery fluid. Fully charge it as early as possible and take sufficient care to keep it warm, e.g. by covering the battery, etc. When leaving the machine outdoors overnight, it is advisable to remove the battery and store it in a warm room.

Avoid measuring the specific gravity of the battery fluid immediately after operation. Instead, wait until the fluid temperature has cooled down to match the outside air temperature.

Measure the specific gravity and estimate the charge rate using the table below.

### Specific gravity of battery fluid

Charging rate	Battery fluid temperature		
	-20°C	0°C	20°C
100%	1.31	1.29	1.28
90%	1.29	1.28	1.26
80%	1.28	1.26	1.25
75%	1.27	1.25	1.24

### Post-operation

To prevent issues like restricted movement of the track assembly due to the icing of mud, water, and other debris on the machine, adhere to the following guidelines:

- Carefully remove any mud and water adhering to the track assembly. Park on dry and firm ground to prevent the track assembly from freezing.
- Wipe the cylinder rod clean. If frozen mud or water adheres to the cylinder rod's surface, it may damage the seal during retraction. Therefore, retract each cylinder to its minimum extension and minimize the exposed portion of the rod as much as possible.

### 14.2 Use in waterfront operations

After operation, thoroughly wash the vehicle to remove any salt residue. Apply oil, grease, or similar substances to prevent rust, as needed.

### 14.3 Use in dusty sites

- Clean and replace the air filter element early.
- To avoid dust clogging the tank core, clean it in advance.
- When refueling, avoid dust mixing in. And check the filter cartridge in advance.
- To prevent the buildup of dust on the starter, alternator, and other components, clean them thoroughly in advance.

## 15 Precautions for long-term storage

When storing the product for a long period of 1 month or more, pay attention to the following points when storing the product in order to prevent the function from deteriorating the next time it is operated.

### 15.1 Wash the vehicle

Wash the vehicle carefully and inspect the track assembly for any anomalies. If any are found, perform maintenance and touch up paint on peeling or damaged areas. Use a grease gun to fill all parts with grease.

#### A Attention

Do not wash your vehicle while inside the cab.

When washing the vehicle, ensure to cover it properly to prevent water and steam from reaching the CPU and electrical components.

### 15.2 Oil and grease filling

Check the oil level and stains of the fuel and working oil, and refill the oil when it is insufficient and replace it when it is heavily stained.

- To prevent condensation in the fuel tank, fill it with clean, fresh fuel up to the upper limit.
- Apply rust preventive oil generously to areas prone to rust, particularly the exposed portion of the cylinder piston rod.

### 15.3 Battery

- To compensate for self-discharge in storage, recharge once a month.
- Turn off the power supply by setting the battery power switch to the OFF position.
- Remove the battery (-) terminal, remove it from the machine and store it.

When removing the battery, even if the battery power switch is turned "OFF", connecting the (-) terminal of the battery to the vehicle body (ground) with a tool or the like may cause a short circuit.

#### Additional instructions

- A warning tone will sound if the cover of the battery power cutoff switch is opened after the engine has stopped.
- Set the battery power switch to "0 (OFF)", or turn the start key switch to "OFF" for at least 5 minutes before removing the battery terminals.

If the battery power is cut off immediately after the engine stops, there is a risk of damaging the exhaust cleaning device.

#### 15.4 Cooling water

When there's a possibility of icing, add non-amine antifreeze to the water tank.  
Typically, changes are unnecessary due to the long-life cooling water used at the factory.

#### 15.5 Dust and moisture resistant

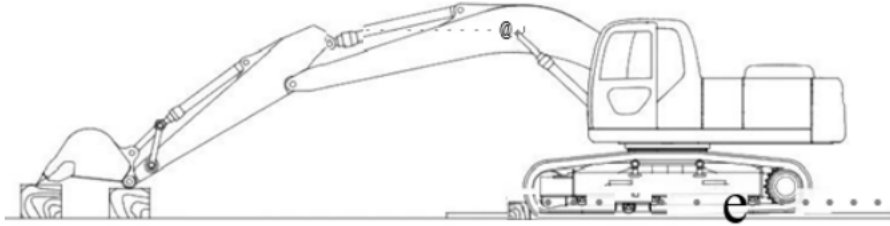

Store in a dry room. If you have to place it outdoors, place wood on a flat surface to protect the machine. Pay particular attention to the muffler, working fuel tank vent pipe, fuel tank cover, and rotary motor level gauge section, and cover the cover.

To protect the exposed portion of the rod, retract the arm and bucket cylinders to their shortest extension, be sure to lower the bucket to the ground and block the tracks with a block.

#### 15.6 Regular lubrication runs (in custody)

Start the engine once a month to operate the machine, and at the same time make a lubrication run so that the oil flows to all parts of the machine. If the oil film on each part dissipates and rust forms, it may lead to abnormal wear during the next operation.

- When starting the engine, check the oil level and cooling water level, and refill them if they are insufficient. Carefully wipe off the rust preventive oil from the cylinder rod. After the lubrication operation, reapply.
- After the engine is started, perform a full warm-up.
- When storing the machine indoors, ensure proper ventilation during the warm-up process.

#### Lubrication operation

1. Slowly reciprocate each cylinder to circulate working oil to all operating circuits.
2. Perform rotating and traveling operations slowly to circulate the working oil.

#### 15.7 Use after long-term storage

When using the machine again after a long period of shutdown, perform the following operations.

- Loosen the plugs of the travel reducer and swing reducer to remove any debris and moisture that may have accumulated during long-term storage.
- The lubricant will still deteriorate during periods of inactivity, so take due care when using it again.
- After long-term storage, carefully check the oil pressure hose for deterioration. Replace the deteriorated hose.
- Carefully wipe off the rust preventive oil from the cylinder rod.
- Grease all parts.
- When starting the engine, check the oil level and cooling water level, and refill them if they are insufficient.
- After the engine is started, run the warm-up sufficiently, and operate the traveling,

rotating, and digging motions repeatedly for several times to prevent the oil film of the working oil from disappearing.

- When storing the machine indoors, ensure proper ventilation during the warm-up process.

## Check and maintenance

### 1. Periodic replacement of important safety parts

The following components might experience aging, wear, and fatigue due to changes over time and repeated use, potentially resulting in significant accidents.

It is challenging to determine the lifespan of these parts through visual check or operational feel, hence they are referred to as "Periodic Replacement of Important Safety Parts". When it's time for a replacement, visit our nearest sales store and ensure you replace it regularly.

※ Certain marked parts might not be included, depending on the model.

No.	Usage part	Commercial name	Replacement time	Reasons for choosing
1	Fuel tank	Fuel hose	Every two years	Possible fire hazard due to fuel leakage.
2	Injection pump	Fuel hose	Every two years	
3	Air conditioner	Hose between air conditioner and compressor	Every two years	Possible malfunction due to refrigerant leakage.
	Heater (optional part)	Hose between engine and heater	Every two years	Possible accidents due to hot water overflow.
4	Water tank hose	Hose	Every two years	
5	Suction and supply hoses	Hose	Every two years	Possible fire hazard due to fuel leakage.
6	Boom cylinder oil pipe	Hose	Every two years	In the event of an oil leak, maintaining the working device in position becomes challenging and may lead to it falling.
7	Arm cylinder oil pipe	Hose	Every two years	
8	Bucket cylinder oil pipe	Hose	Every two years	
9	Rotary motor oil pipe	Hose	Every two years	Possible malfunction due to oil leakage.
10	Return pipe	Hose (O-ring)	Every two years	
11	DPF (Sensor hose) DPF(Support)※	Hose Support	Every two years	DPF damage may cause a fire.
12	Seat belt	Seat belt	Every three years	If the machine tips over, it could experience a strong impact, become crushed, or undergo other severe consequences, potentially resulting in a fatal accident.

#### **A Warning About the use of pilot hoses, hard tubes and high-pressure hoses**

Do not bend or knock the high-pressure hose. Never use broken pilot hoses, hard tubes or hoses. When the fuel hose and oil piping are sagging or damaged, repair them. Be especially mindful that oil leaks can result in fires.

Do not check leakage areas by hand. Ensure that all connectors are properly torqued.

Check all pilot piping, hard tubes and high-pressure hoses, noting the following:

- Damaged or leaking terminal connections.

- Breakage of exterior guard boards.
- Visible damage to the hose's moving part
- Whether the metal guard board is broken or not
- Loose connections

**Important**

- When you replace the hose, make sure to also replace the O-ring and seal rings.
- When checking and replacing the hose, also replace the clamp if you notice any deformation or cracks in the oil hose clamp.
- When replacing the fuel hose, carefully adhere to the correct assembly position to prevent fire hazards.

**2. Recommended oil viscosity and replacement capacity**

Regardless of the atmospheric temperature, use the following oils for the reducers listed below:

- Rotary reducer: Gear oil #90 API classification GL-4 grade
- Traveling reducer: Gear oil #90 API classification GL-4 grade

**ME80**

Container(s)	Type of liquid	Ambient temperature											Capacity
		-40	-22	-4	14	32	50	68	86	104	122F	Regulation	
		-40	-30	-20	-10	0	10	20	30	40	50°C		
Oil sump	Engine oil												9L
Hydraulic oil system													88L
Fuel tank	Diesel oil												130L
Cooling system	Water	Add											13L
		(-25°C)											

**Additional instructions**

For original grease and coolant, contact our sales store.

- If you discover oil leakage and damage to the lower track roller, upper track roller, and front guide wheel, contact our sales store to arrange for repairs.

- Be sure to use the specified fuel. To achieve optimal fuel consumption and emission characteristics, this machine's engine uses an electronically controlled high-pressure fuel injection unit.

The unit demands high precision and lubricity, so using low-viscosity fuels with poor lubricity may greatly reduce its durability.

**Additional instructions**

When replacing and replenishing long-life working oil, make sure to use the specified grease. Using unspecified working oil or mixing it with other types of working oil will decrease performance and necessitate more frequent working oil changes.

**Additional instructions**

This machine is designed to function in a well-maintained condition within an ambient temperature range of -20°C to 40°C (-4°F to 104°F).

**Fuel benchmark**

- The fuel should have a cetane number of 45 or higher. Diesel with a cetane number higher than the said value is necessary for operations in cold areas and at high altitudes.
- The sulfur content must not exceed 15 ppm by total mass. Typically, using fuel with a high sulfur content can lead to sulfuric acid corrosion within the engine and cylinders.

Especially in the U.S. and Canada, ultra-low sulfur fuel must be used. Additionally, within the EU, the sulfur content must be below 10 ppm by overall weight (less than 15 ppm at final sale).

- During cold periods, to prevent the fuel from freezing, use diesel that remains effective at temperatures up to 12°C (53.6°F) below the expected minimum temperature.

**Prohibitions**

- Never use kerosene.
- Never mix kerosene or used oil with diesel.
- Never use residual oil as it can cause clogging of the diesel filter and lead to carbon buildup in the nozzle.
- Never use fuel that has been stored in drums or similar containers for a long period of time.
- Never store fuel in containers with galvanized interior walls.
- Never use fuel purchased from an unauthorized dealer.
- Fuel additives are not recommended. Certain fuel additives can deteriorate engine performance. Additives with alcohol content, such as drain agents, may adversely affect fuel sealing parts and cause fuel leaks.

**5. Wearable parts**

Wearable parts such as filters and elements should be replaced during regular maintenance or before the wear limit is reached. Replacing the wearable parts as needed can make the use of this machine more economical.

Part numbers may be changed without prior notice.

When ordering parts, confirm the part number with our sales store.

**Checklist of consumables**

Item		Product name	Quantity	Replacement time
Working oil tank		Oil return filter element kit (breaker hammer)	1	Replacement every 2000 hours (1000 hours for breaker hammers)
Working oil tank		Suction filter mesh	1	Replacement every 2000 hours (1000 hours for breaker hammers)
Ventilation valve		Filter element	1	Every 1,000 hours, using this interval as a rough standard. Replace it earlier at locations with high levels of sand and dust.
Air filter		Filter element (outer)	1	Clean 6 times or replace annually
		Filter element (inner)	1	Replace the outer filter element simultaneously (no cleaning required)
Oil filter		Filter cartridge	1	First 50 hours, every 250 hours thereafter
Fuel filter	Main	Filter element	1	Replacement every 250 hours
	Primary	Filter element	1	
Air conditioner		Exterior air filter	1	Clean approximately 10 times. If the mesh becomes significantly clogged, either clean or replace it
		Interior air filter	1	
Pilot oil circuit filter		Pilot oil circuit filter	1	Cleaning every 1000 hours
Water tank		Water tank cap	1	Replacement every 2000 hours
Bucket		Side cutters	1	Unscheduled
		Side cutters	1	
		Bolts	6	
		Nut	6	
		Bucket teeth assembly	5	

### 6. Check the tightening torque of bolt and nut

The reference values in the table below show the tightening torque to be applied when no specific value is indicated.

Bolts that are over-tightened can deform or break under load, while bolts that are insufficiently tightened may loosen or fall off. Therefore, the bolts should be tightened with the appropriate torque.

#### Tightening torque for metric bolts with coarse thread (without plating)

Size	Strength classification	4.8	7	10.9

	Use classification	Unlubricated	Lubricated	Unlubricated	Lubricated	Unlubricated	Lubricated
M6	P=1	4.4±0.4	3.7±0.4	9.7±1.0	8.1±0.8	17.4±1.7	14.7±1.5
M8	P=1.25	10.7±1.1	9.0±0.9	23±2.3	19.6±1.9	42±4.2	35±3.5
M10	P=1.5	21.5±2.1	18±1.8	46.5±4.6	39±3.9	84±8.4	70±7.0
M12	P=1.75	36.5±3.7	31±3.1	80±8.0	67±6.7	144±14	121±12
M14	P=2	58±5.8	49±4.9	126±13	106±11	230±23	192±19
M16	P=2	88±8.8	74±7.4	191±19	161±16	345±34	290±29
M18	P=2.5	122±12	103±10	265±26	225±22	480±48	400±40
M20	P=2.5	171±17	144±14	370±37	310±31	670±67	560±56
M22	P=2.5	230±23	192±19	500±50	420±42	900±90	755±75
M24	P=3	295±29	245±25	640±64	540±54	1150±115	970±97
M27	P=3	435±43	365±36	940±94	790±79	1700±170	1420±142
M30	P=3.5	590±59	495±49	1280±128	1080±108	2310±231	1940±194
M33	P=3.5	795±79	665±66	1730±173	1450±145	3110±311	2600±260
M36	P=4	1020±102	860±86	2230±223	1870±187	4010±401	3360±336

### Tightening torque for metric bolts with fine thread (without plating)

Unit: N ·m

Size	Strength classification	4.8		7		10.9	
		Unlubricated	Lubricated	Unlubricated	Lubricated	Unlubricated	Lubricated
M8	P=1	11.3±1.1	9.5±0.9	24.5±2.4	20.5±2.1	44±4.4	37±3.7
M10	P=1.25	22.5±2.2	18.7±1.9	48.5±4.8	40.5±4.1	87±8.7	73±7.3
M12	P=1.25	39.5±3.9	33±3.3	86±8.6	72±7.2	154±15	129±13
M16	P=1.5	93±9.3	77±7.7	200±20	168±17	365±36	305±30
M20	P=1.5	186±19	155±15	405±40	335±34	725±73	605±60
M24	P=2	315±32	265±26	685±69	575±57	1240±124	1030±103
M30	P=2	640±64	530±53	1390±139	1160±116	2500±250	2080±208
M33	P=2	850±85	710±71	1860±186	1550±155	3350±335	2780±278
M36	P=3	1070±107	890±89	2330±233	1940±194	4200±420	3500±350

### 7. Tightening torque for connectors and hydraulic hoses

#### Additional instructions

The specified tightening torque is applicable when performed without lubrication.

#### ORS connector (O-ring, seal type)

Hose port and connector size	Using an open-end wrench (mm)	Tightening torque N ·m {kgf ·m}
1-14UNS	30	137±14 {14±1.4}
	32	

1-3/16-12UN	36	177±18 {18±1.8}
	41	
1-7/16-12UN	41	206±21 {21±2.1}
	46	

### Snap-fit connector

Hard tube size Outer diameter × thickness (mm)	Using an open-end wrench (mm)	Tightening torque N · m {kgf · m}
10×1.5	19	49±5 {5±0.5}
15×2.0	27	118±12 {12±1.2}
18×2.5	32	147±15 {15±1.5}
22×3.0	36	216±22 {22±2.2}
28×4.0	41	275±28 {28±2.8}
35×5.0	55	441±44 {45±4.5}

### O-ring connector

Screw diameter (PF)	Using an open-end wrench (mm)	Tightening torque N · m {kgf · m}
1/8	14	17±2 {1.7±0.2}
1/4	19	36±4 {3.7±0.4}
3/8	22	74±7 {7.5±0.5}
1/2	27	108±11 {11±1.0}
3/4	36	162±16 {17±1.6}
1	41	255±26 {26±2.7}
1-1/4	50	392±39 {40±4.0}

### Hydraulic hose

Screw diameter (PF)	Using an open-end wrench (mm)	Tightening torque N · m {kgf · m}
1/8	17	20±2 {2.0±0.2}
1/4	19	29±3 {3.0±0.3}
3/8	22	49±5 {5.0±0.5}
1/2	27	78±8 {8.0±0.8}
3/4	36	118±12 {12.0±1.2}
1	41	137±14 {14.0±1.4}
1-1/4	50	167±17 {17.0±1.7}

### Split flanges

Name Size	Tightening torque N · m {kgf · m}			
	Using pressure 20.6 Mpa	Bolt size (M)	Using pressure 41.2 Mpa	Bolt size (M)

	{210 kg/cm <sup>2</sup> }		{420 kg/cm <sup>2</sup> }	
3/4	33.9±3	10	39.5±4	10
	{25±2.5}		{29±2.9}	
1	42.4±4	10	62.2±6	12
	{31±3.1}		{46±4.6}	
1-1/4	55.1±6	10	93.3±9	14
	{41±4.1}		[69±6.9]	
1-1/2	70.6±7	12	169±17	16
	{52±5.2}		{125±12}	
2	81.9±8	12	282±28	20
	[60±6}		{208±21}	

**Additional instructions**

The specified tightening torque for split flanges is applicable when tightening is performed without lubrication.

## 8. Check and maintenance checklist

The table below outlines our recommended schedules for regular and timer interval greasing, filter element replacement, and check and maintenance programs for various equipment. Conduct check and maintenance at frequent intervals according to the timer and calendar.

### About the symbols in the table

Timer interval indicates the periodic check and necessary items.

⊙ Only required at the first specified interval.

○ Intervals at which check and maintenance are needed.

### Engines

Item/interval		Unscheduled	Pre-operation checks 8H 50H	Every 1 month or 100H	Every 3 months or 250H	Every 6 months or 500H	Every 12 months or 1,000H	2,000H	5,000H	Grease (replacement of parts)
Engine oil	Oil level check		○							Engine oil
	Replace		⊙ (Initial)		○					
Oil filter replacement			⊙ (Initial)		○					Filter cartridge
Fuel coarse filter	Drain water		○							Filter cartridge
	Replace				○					
Fuel filter					○					Filter cartridge
Exhaust after-treatment unit ※ DPF and related parts	Inspection						○ (3000H)			
	Cleaning							○ (6000H)		
	Replace								○ (9000H)	
Check the air filter intake			○							
Air filter element	Inspection and cleaning		When the warning light is activated (up to 6 times)		○					Outer filter elements (No cleaning for inner screen)
	Replace		Clean the outer filter mesh 6 times or				○			Outer and inner filter elements

				after 1 year						
Cleaning of water tank cooling water and cooling system	Water level check		O							
	Replacement and cleaning							O (or every 2 years)		LLC
Water tank hose crack and damage check						O				
Cleaning of water tanks, oil cooler cores, intercoolers and filters						O				
Fan belt and air conditioner belt	Inspection		O							
	Adjustment			⊙ (Initial)		O				
Water tank cap cleaning or replacement	Cleaning					O				
	Replace						O			
Check the fastening status of the engine mounting bracket								O		
Check of rubber hoses in the air intake system						O				

Item/interval	Unscheduled	Pre-operation checks 8H 50H	Every 1 month or 100H	Every 3 months or 250H	Every 6 months or 500H	Every 12 months or 1,000H	2,000H	5,000H	Grease (replacement of parts)
※ Spot check for bleeding color, rattles, and odors		O							
※ Check and maintenance of valve clearance						O			
※ Spot check and cleaning of fuel injection valve								O (3000H)	
※ Spot check and adjustment of starters and alternators						O			
※ Spot check and cleaning of supercharger								O (3000H)	
※ Action check of intake throttle valve								O (3000H)	
※ EGR cooler cleaning								O (3000H)	
※ Spot check for crankcase ventilation system							O (1500H)		
Inspection for oil and fuel leakage in each part		O							

Check for water leakage in each part		○								
Check of the electrical system		○								

**Important**

For check and adjustment of the items marked with an asterisk (※), contact our sales store.

## Fuel system

Item/interval		Unscheduled	Check before starting operation 8H	50H	Every 1 month or 100H	Every 3 months or 250H	Every 6 months or 500H	Every 12 months or 1,000H	2,000H	5,000H	Grease (replacement of parts)
Fuel tank	Oil level check										
	Drainage of water and sediment		O								
	Cleaning of protecting covers and filter meshes					O					
Air exhaust of fuel piping		O									

## Hydraulic system

Item/interval		Unscheduled	Check before starting operation 8H	50H	Every 1 month or 100H	Every 3 months or 250H	Every 6 months or 500H	Every 12 months or 1,000H	2,000H	5,000H	Grease (replacement of parts)
Hydraulic oil tank	Oil level check		O								Hydraulic oil
	Replace							O (Breaker hammers)	O		
	Suction filter element								O		Filter mesh
	Replace the oil return filter					O (Breaker hammers)		O			Filter element
	Ventilation valve filter element replacement							O			Filter element
Check for oil leakage and damage in hydraulic equipment, piping, and hoses			O								
Cleaning of pilot oil circuit filter									O		

## Upper structure

Item/interval		Unscheduled	Check before starting operation 8H	50H	Every 1 month or 100H	Every 3 months or 250H	Every 6 months or 500H	Every 12 months or 1,000H	2,000H	5,000H	Grease (replacement of parts)
Rotary reducer oil	Oil level check		O								Gear oil

	Replace					⊙ (Initial)	○			SAE #90 GL-4
Filling grease to swivel bearings					○					EPG lithium extreme pressure grease
Check of grease in rotary grease troughs								○		EPG lithium extreme pressure grease
Filling grease to the operating lever push rod and universal connectors		○								EPG lithium extreme pressure grease
Swivel bearing assembly Check for looseness of covered screws						○				
Counterweight block installation Check for looseness of flat head screws				⊙ (Initial)		○				
Filling grease to the rotary reducer					○					
Check of structural components			○							

### Lower structure assembly

Item/interval		Unscheduled	Check before starting operation SH	50H	Every 1 month or 100H	Every 3 months or 250H	Every 6 months or 500H	Every 12 months or 1,000H	2,000H	5,000H	Grease (replacement of parts)
Traveling reducer oil	Oil level check				○ (120H)						Gear oil SAE #90
	Replace						⊙ (Initial)	○			GL-4
Track tension adjustment				○							
Check for oil leakage in upper and lower track rollers			○								
Check for oil leakage in guide wheels and traveling reducers			○								
Check for wear in sprockets, guide wheels, and track rollers			○								

### Working device

Item/interval	Unscheduled	Check before starting operation SH	50H	Every 1 month or 100H	Every 3 months or 250H	Every 6 months or 500H	Every 12 months or 1,000H	2,000H	5,000H	Grease (replacement of parts)
Filling grease to the working device		○								EPG lithium

(around the bucket)											extreme pressure grease
Filling grease to the working device		O									
Replacement of bucket	O										
Replacement of bucket teeth and side cutters	O										
Check and adjustment of bucket wobble adjustment mechanism	O										
Check of working device structural components		O									
Filling grease to the dozer blade		O									

### Electrical

Item/interval		Unscheduled	Check before starting operation 8H	50H	Every 1 month or 100H	Every 3 months or 250H	Every 6 months or 500H	Every 12 months or 1,000H	2,000H	5,000H	Grease (replacement of parts)
Battery	Fluid level check					O					
	Specific gravity measurement					O					
	Cooling and greasing					O					
	Voltage measurement							O			
Check of electrical wiring			O								
Working condition of instrumentation, switches and light alarms			O								

### Accessories and other items

Item/interval		Unscheduled	Check before starting operation 8H	50H	Every 1 month or 100H	Every 3 months or 250H	Every 6 months or 500H	Every 12 months or 1,000H	2,000H	5,000H	Grease (replacement of parts)
Air conditioner	Refrigerant level check						O				
	Check and cleaning of condenser					O					
	Filter	Cleaning				O					
		Replace			Cleaning about 10 times						
Check of wiper blades		O									

<b>Check of washer fluid</b>		O									
<b>Check for abnormal deformation and damage of the machine</b>			O								
<b>Check for loose or dislodged bolts and nuts</b>			O								
<b>Seat belt</b>	<b>Inspection</b>		O								
	<b>Replace</b>									O (3 years)	

## 9. Unscheduled maintenance

Carefully review the "Safety" section of this manual and ensure a thorough understanding before conducting any operations, checks, or maintenance.

### 9.1 Check and replacement of wiper blades

Check the wiper blades and replace them if they are worn or damaged.

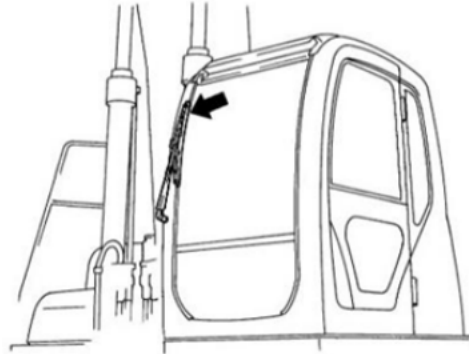

### 9.2 Check of washer fluid

#### Additional instructions

Note that continued use without discharge of the washer fluid may result in failure of the motor mounted on the washer reservoir.

1. Remove the bottom pad.
2. Check the fluid level in washer reservoir 83.

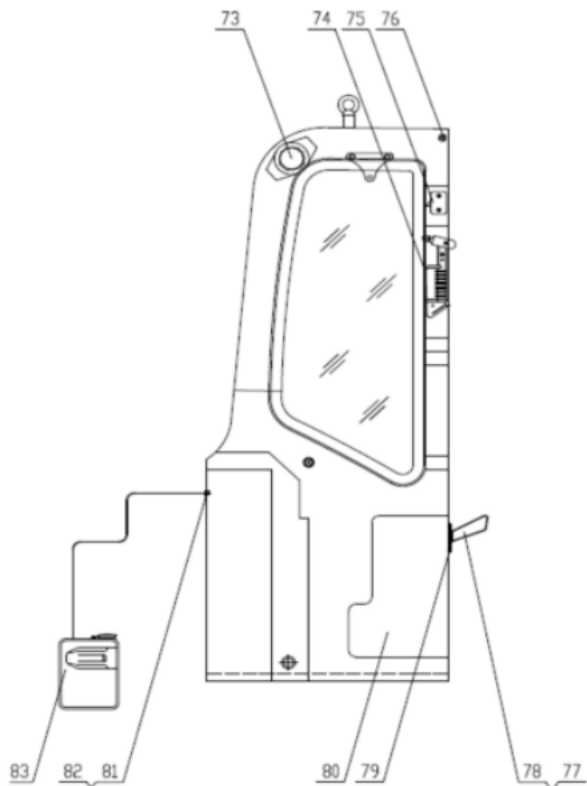

3. When the washer fluid is less than (L), remove the cover and replenish the washer fluid

for automobiles.

4. Put the bottom pad back in its original position.

### 9.3 Replacement of bucket

#### A Attention

- Please choose a site with a flat foundation for your operation. When working together, make sure to signal each other and pay full attention to safety.
- It is very dangerous to operate the front working device suddenly, so never operate it suddenly.
- When installing the pin into the pin hole, never put your fingers inside the pin hole.
- Place the removed bucket in a stable position.

#### Bucket removal

1. Secure the back of the bucket to a flat surface so that the pins of the bucket and the arm do not take excessive stress.
2. Move the O-ring (1) on the pin from its usual location to the bucket protrusion.

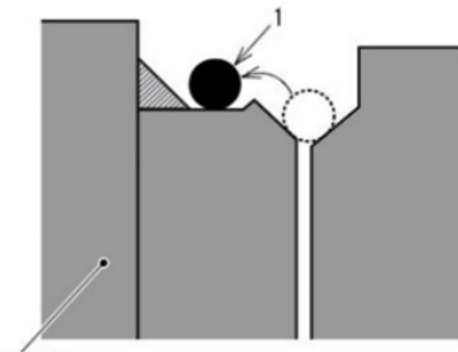

Bucket shaft seat

3. Remove the anti-release elastic ring (2) and pin (3) with a flathead screwdriver.
4. Pull out pins (4) and (5) and remove bucket (6). Be careful not to attach sand and dirt to the pins you pull out. In addition, the pin holes of the arm (7) and bucket linkage (8) are equipped with dust seal rings at both ends.

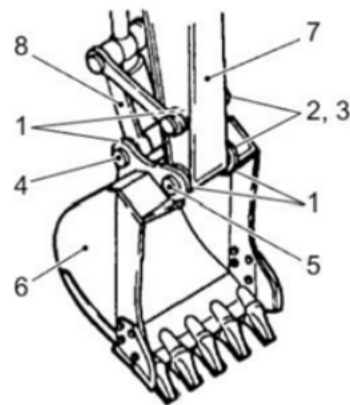

#### Installation of bucket

#### Additional instructions

When the O-ring (1) loses its elasticity or breaks, replace it with a new one.

1. Thoroughly clean the pins and pin holes in each part, and carefully apply grease to ensure proper lubrication.
2. Align the pin holes of the bucket (6) and bucket linkage (8) while moving the bucket cylinder, and then insert the pin (4).
3. Raise the boom so that the bucket is slightly overhanging from the ground.
4. Move the arm (7) and insert the pin (5) after aligning the pin holes of the bucket (6) and arm (7).
5. Insert the pin (3) and install the elastic ring (2).
6. Embed the O-ring (1) in its normal position.
7. Fill grease to the fitting of each pin until it begins to ooze out from the gaps in the pin.

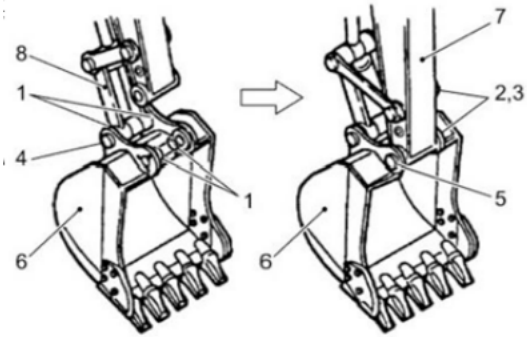

#### 9.4 Replacement of bucket teeth and side cutters

##### A Attention

When replacing the bucket teeth and side cutters, set a safety pier (sleeper) on the bottom of the bucket.

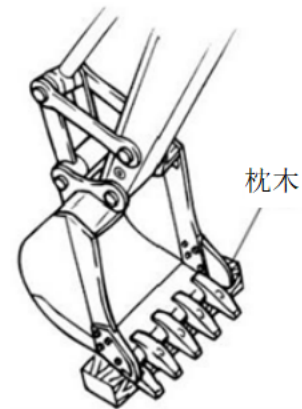

Check the bucket teeth as well as the side cutters for wear. For bucket teeth with holes or cracks, replace them before they are worn to the connector (1). Also, badly worn side cutters should be replaced as soon as possible. If replacement is delayed, damage to the bucket body may result.

- (1) Connector
- (2) Bucket teeth
- (3) Rubber locking pin
- (4) Locking latch
- (5) Side cutters
- (6) Bolts
- (7) Nut

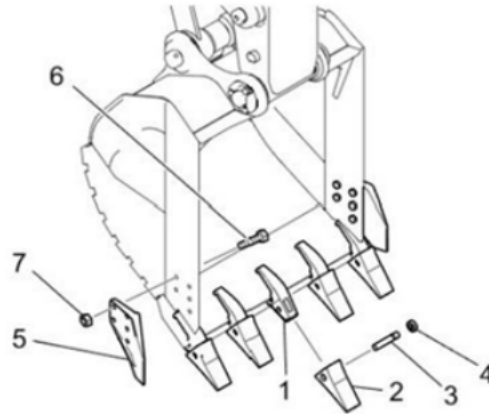

**Essentials for replacement of bucket teeth**

**A Attention**

Metal flakes can be splashed during impact operations, which can lead to major injuries, especially when splashed in the eyes. Use protective equipment such as goggles, helmets, gloves, etc. when performing work.

1. Using a striking tool and hammer, tap out the locking pin (3), taking care not to damage the spring (4).

2. Investigate the removed locking pin (3) and spring (4).

Replace the too short locking pin (3) and defective spring (4) with new ones.

3. Use a scraper to clean the surface of the bucket teeth (2) to remove any adhering sand and soil.

4. Embed the spring (4) in the side grooves of the bucket teeth (2).

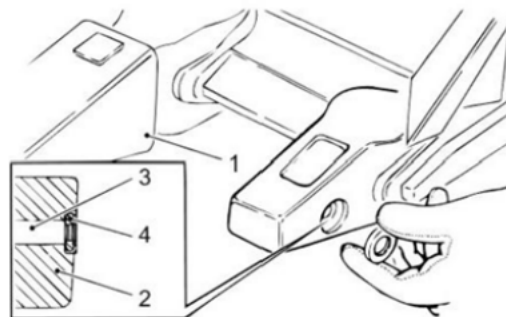
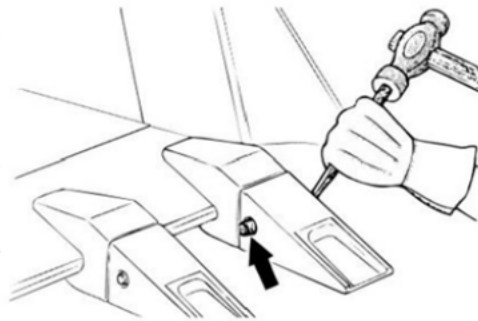

5. Embed the bucket teeth (1) in the bucket teeth (2).

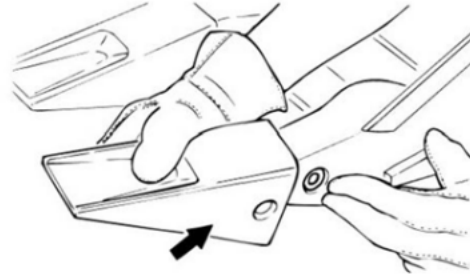

6. Tap the locking pin (3) to the same height as the surface of the bucket teeth (1).

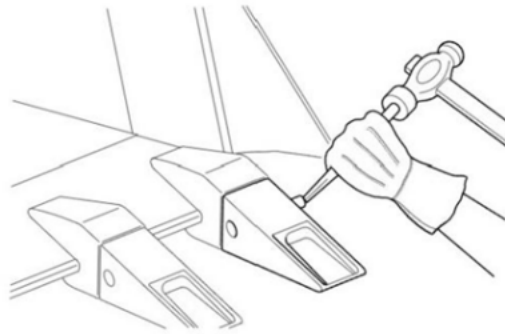

### Essentials for replacement of side cutters

#### Additional instructions

If replacement is delayed, damage to the bucket body may result. Make the replacement as soon as possible.

1. After removing any sand, dust, etc. attached around the mounting bolts, air cut the fixing bolts and remove the side cutter.
2. Ensure the mounting surface is clean before installing the new side cutter.

When replacing the side cutter, be sure to replace the bolts and nuts with new ones. Tightening torque:  $539 \pm 54 \text{ N}\cdot\text{m}$

3. After tightening the nuts, spot weld each nut

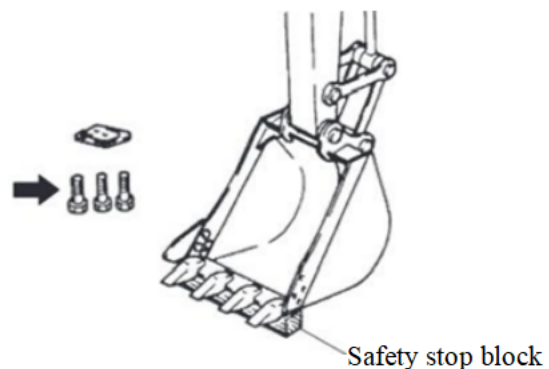
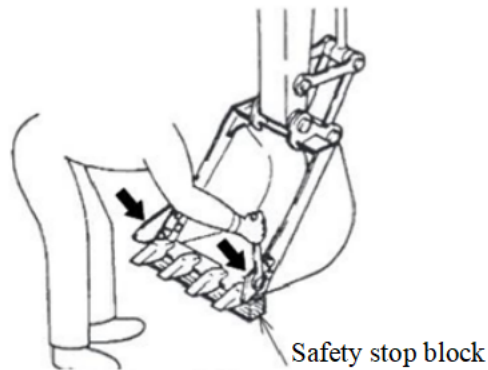

### 9.5 Check and adjustment of bucket wobble adjustment mechanism

#### A Attention

- To adjust the bucket's wobble, place the lifting hydraulic locking lever in the "locked position" and turn off the engine.

- If the bucket's wobble is not properly adjusted, the contact surface between the bucket and arm may become scratched, resulting in strange noises and potential damage to the shaft and O-ring.

1. Make the bucket touch the ground in a stable condition as shown in the illustration.

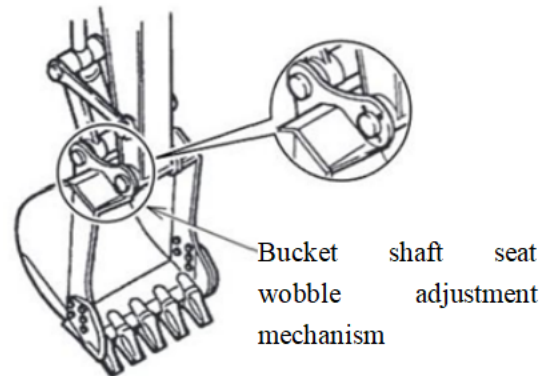

2. Move the O-ring (1) from its normal position toward the bucket shaft seat area.
3. Turn slightly to the right and gently press the front of the arm against the right side of the bucket, the side without the wobble adjustment mechanism.
4. Place the lifting hydraulic locking lever in the "locked position" and turn off the engine.

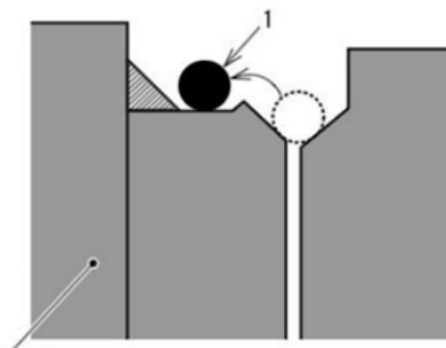

Bucket shaft seat

5. Measure the clearance (A) section between the bucket and the arm shaft seat. If the measured value exceeds 1.2mm, make adjustments.
6. Loosen each bolt and take off the number of shims for the amount of clearance.
- Put 5 shims (3) (1mm) equally in the 3 bolts (2) of the gap adjustment section.
7. Tighten the bolts (2) evenly with the specified tightening torque. Tightening torque:  $115 \pm 12 \text{ N}\cdot\text{m}$
8. Return the O-ring (1) to its normal position.

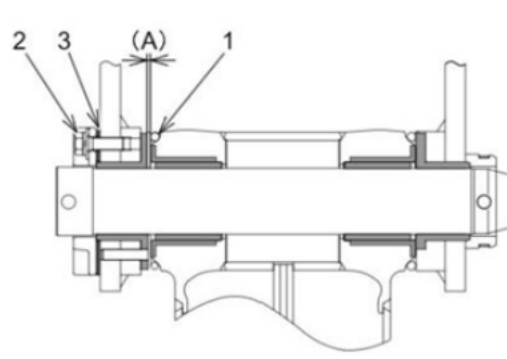

## 9.6 Diesel system bleeding

Air mixed or trapped in the diesel system can result in failure to transport diesel to the diesel injection pump. When the diesel tank is "empty" or the diesel filter element is replaced, air will get trapped. Therefore, make sure to vent the tank.

### Essentials for bleeding

1. Place the locking lever to the "locked position" and turn off the engine.
2. Fill the diesel tank with diesel.
3. Please confirm that the faucet of the diesel filter element 3 is in the "open" position.
4. Adjust the starter key to the "ON" position for 90 seconds or more to feed fuel to the fuel system through the fuel supply pump.

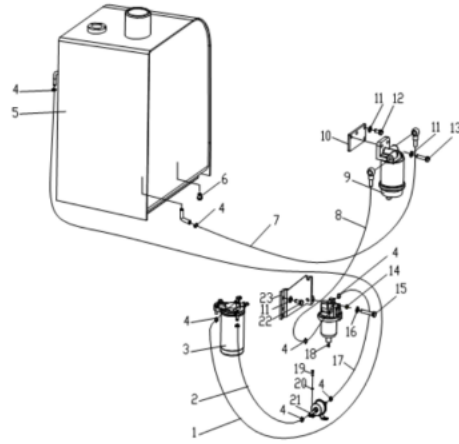

### Additional instructions

- Do not run the starter motor while feeding fuel to the fuel system. The starter can heat up and potentially damage components such as coils, pinions, and ring gears.
- If you need to continue using the starter, wait for at least 30 seconds before trying again.

### 10. Maintenance every 8 hours (or every day)

Read the "Safety" section of this manual carefully, and operate, check and maintain the product with a good understanding of the safety requirements.

Conduct daily checks and maintenance before and after operation, following the guidelines in "Check Before Starting Operation", "Check Before Starting the Engine", and "Check After Starting the Engine" (both before and after starting work).

#### 10.1 Filling grease to the working device

See the figure on the right. The machine needs to be greased. Clean the grease fitting prior to applying grease.

The grease gun can be placed inside the protecting cover at the right rear of the machine.

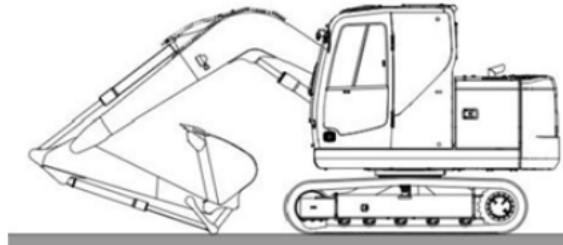

### Additional instructions

Notes on grease filling:

- Fill grease every 8 hours to the designated areas
- If digging in water or using grease, additional grease must be filled at that moment.
- After using specialized working devices like hydraulic shears and hammers for demanding operations, it is essential to refill the grease daily.
- If the machine will be unused for more than a month, be sure to refill the grease before operating it again.

Lubricate the two grease fittings (1) on the idler link, the grease fitting (2) on the bucket cylinder rod, the grease fittings (3) on both the left and right sides of the bucket connecting rod, and the grease fitting (4) on the front end of the arm.

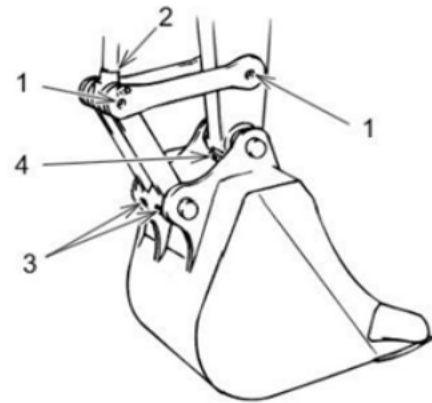

- Fill grease to the grease filler ports (1) and (2) of the boom cylinder head and the cylinder rod.
- Fill the grease fitting (4) near the bottom of the boom and the grease filler (3) on the center side of the boom.

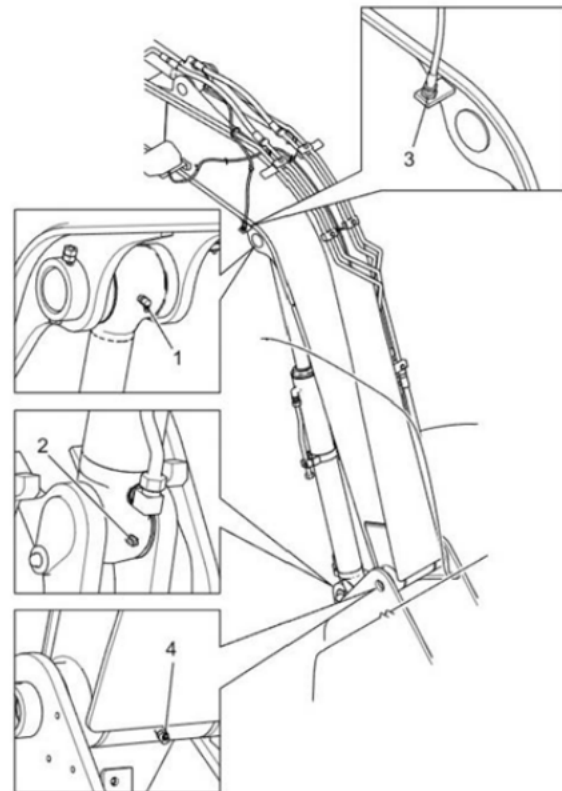

**A Attention**

Do not climb on the machinery or the bulldozing plate to refill the grease, there may be a risk of falling.

- Fill grease to the arm cylinder piston rod (5), grease fitting (6) on the boom and arm joint and the bucket cylinder head (7).

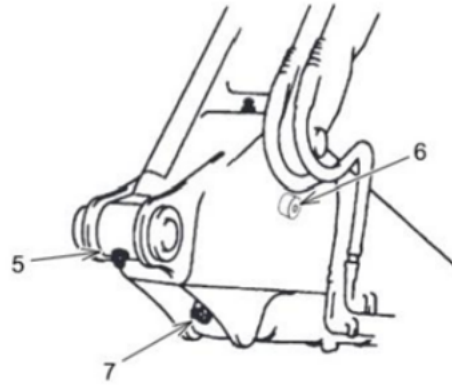

## 10.2 Filling grease to the dozer blade

### Additional instructions

Requests for grease filling

- Fill grease every 8 hours to the designated areas.
- When working in water, fill grease to the submerged parts both before and after each day's operation.
- For severe operations involving special working devices, fill grease daily.
- If the machine has been out of operation for more than a month, fill grease before using it again.
- Fill grease to the grease filler ports (1) on the dozer blade cylinder head, the cylinder rod, and the grease filler port (2) in the scraper mounting section.

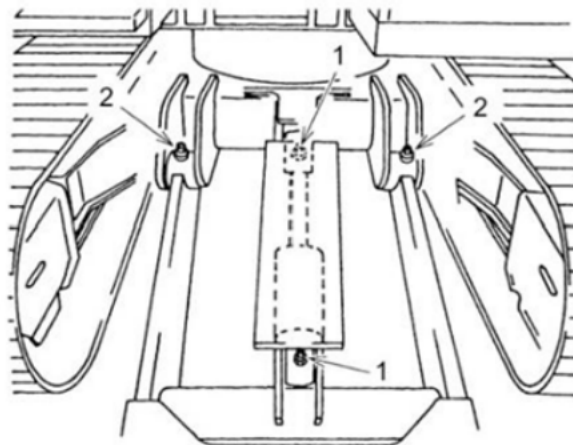

## 11. Maintenance every 50 hours

Carefully review the "Safety" section of this manual and ensure a thorough understanding before conducting any operations, checks, or maintenance. In addition, perform the "Maintenance every 8 hours (or every day)" concurrently.

### 11.1 Drainage of water and sediment from fuel tanks

#### A Warning Treatment of fuel

- Spilled fuel can cause a fire, so wipe it up thoroughly.
- After operation, please confirm there are no fuel leaks.

1. Move the machine to a sturdy and level place.
2. Fully open the release plug (1) located under the fuel tank. Slightly turn the upper swivel body to allow the bucket to touch the ground.
3. Please stop the engine and place the lifting hydraulic locking lever in the locked position.
4. Place a container for the drain oil under the release plug (1).
5. Insert your hand through the hole in the lower guard board and open the discharge cock (1) to drain the water and sediment that have accumulated at the bottom.

Be sure to avoid spilling any fuel during this process.

6. If clean diesel oil comes out, turn on the drain plug (1).

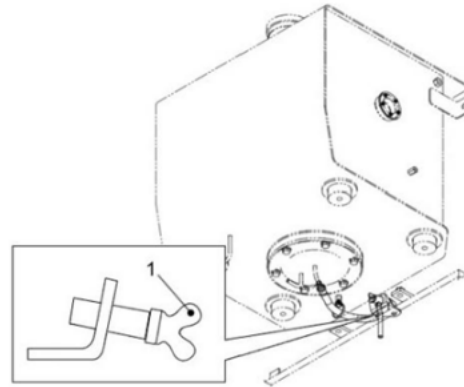

## 11.2 Track tension adjustment

### Additional instructions

- When checking or adding grease, clean the sand and dirt around the tracks, etc., and remove them thoroughly before proceeding.
- Tensioning of the tracks needs to be adjusted to suit the site operation. On a site with a lot of gravel and cobblestones, spread the tracks slightly looser; on a solid foundation, spread the tracks slightly tighter.

### Check track tension

- One side at a time, with the track to be measured for tension in suspension, measure the upper side of the track shoe against the lower side of the track frame.

In this case, support the lifted body with a support base or the like.

A: Suitable tension

Iron track shoes: 200~230mm

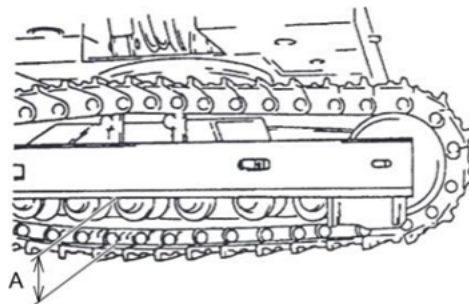

## Essentials for tensioning the tracks

### A Warning About track anomalies

When the tracks cannot be adjusted, an anomaly has occurred.

The track springs are subjected to strong forces. The grease in the cylinder is under high pressure. Incorrect operation in adjustment, disassembly, etc. will be very dangerous and may lead to fatal accidents.

1. Use a grease gun to add grease to the grease fitting (1) of the guide wheel adjusting spring assembly of the lower frame assembly to tension the tracks.
2. To equalize left and right track tension, move the machine forward and backward to allow for even pressure.
3. Check the track sag again and adjust it again as needed.
4. Do the same for the other side of the track

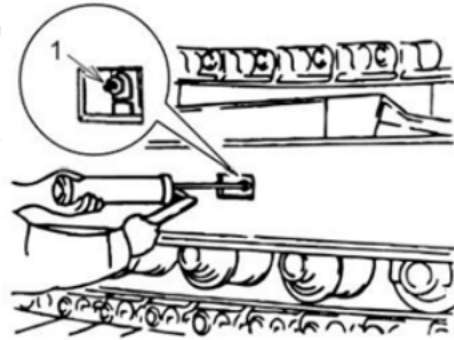

## Essentials for loosening the tracks

### A Warning About the use of grease hydraulic cylinders

Due to the high pressure within the grease hydraulic cylinder, abruptly loosening the grease fitting can cause high-pressure grease to spray out, potentially resulting in serious or fatal accidents. Keep your face and body away from the grease fitting, and loosen it slowly.

To prevent high-pressure grease from spraying out of the grease fitting, do not loosen it more than one turn.

1. Place the machine in a sturdy and level place.
2. Slowly loosen the grease fitting (1) on the grease hydraulic cylinder, ensuring not to exceed one turn, to release the grease. If the grease is not draining well, position the track so that it overhangs on the unscrewed side and allow the track to rotate slightly.
3. After setting the track tension to the proper level, tighten the grease fitting (1). For the tightening torque, refer to "Tightening Torque of Bolts and Nuts (specific parts)".

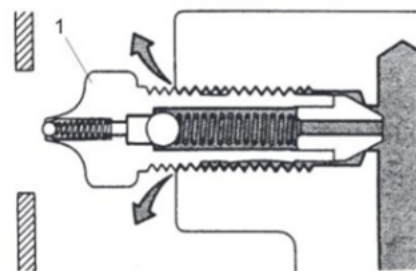
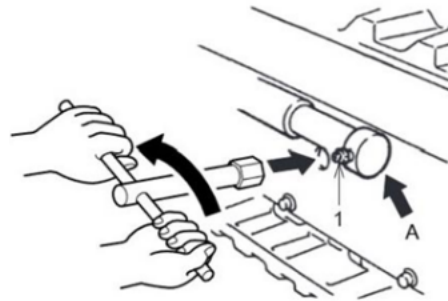

Detail of part A (grease drain)

## 12. Every 100 hours maintenance

Carefully review the "Safety" section of this manual and ensure a thorough understanding before conducting any operations, checks, or maintenance. In addition, perform the "Check Before Starting Operation and Maintenance every 50 hours" concurrently.

### 12.1 Oil level check of traveling reducer

#### A Warning About the oil level check

- Wear goggles when refilling the oil.
- Sometimes there is residual pressure inside the driving unit. Release the plug slowly to release the pressure and then remove the plug. When releasing the plug at once, the plug and oil flying out can pose a danger. Never put your body or face in front of the plug.
- Just after running, the oil is hot and there is a danger of scalding. Wait until the temperature drops before starting the operation.

1. Move the machine to a sturdy and level place.

2. Stop the machine with the drain plug (1) on the lower side so that the bucket touches the ground.

3. Please stop the engine and place the lifting hydraulic locking lever in the locked position.

4. Slowly release the filler plug (3) to relieve the pressure.

5. Remove the level plug (2) and check the gear oil level and contamination. As long as the liquid level is at the mouth edge of the level plug it is normal.

6. When the gear oil is insufficient, remove the level plug (2) and the filler plug (3) and refill with the specified gear oil.

For the specified gear oil, refer to "Recommended Oil Viscosity and Replacement Capacity".

7. Use diesel oil to clean the level plug (2), the filler plug (3), and then install.

8. Use the same procedure to check the traveling reducer on the other side.

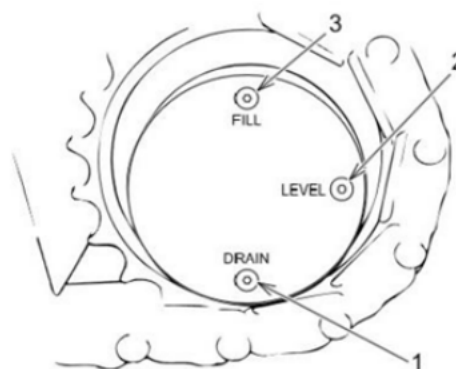

## 13 Maintenance every 250 hours (or 3 months)

Carefully review the "Safety" section of this manual and ensure a thorough understanding before conducting any operations, checks, or maintenance. In addition, perform the "Check Before Work and Maintenance every 50 hours and 100 hours" concurrently.

### 13.1 Adjustment of fan belt and air conditioner belt

#### Check of fan belt and air conditioner belt

#### A Warning About belt check and maintenance

Ensure the engine is turned off before performing any checks or maintenance.

If check or maintenance is performed while the engine is running, you risk getting caught in

the rotating parts of belts, fans, etc., which can result in serious personal injury.

**A Attention**

During checking, if you find localized cracks or breaks in the belt, or significant slipping that prevents adjustment within the specified range, replace the belt with a new one. Avoid applying oil to the belt, as it will cause slippage and shorten its lifespan.

**Additional instructions**

- After replacing a new belt, let the engine idle for 3 to 5 minutes to accommodate the initial belt fit. Then, reconfirm and adjust the belt tension as needed.
- The new belt should run for approximately 2 hours to fully release its initial elongation.
- When replacing a set of 2 belts, be sure to replace both with new ones.

The engine of this machine is equipped with an alternator, a fan, and a belt for the air conditioner.

To maintain maximum engine performance, longevity, check these belts for wear and damage, and check the belt tension and adjust it properly.

**Additional instructions**

For the adjustment of each belt, refer to Chapter 4, "Adjustment of Fan Belt and Air Conditioner Belt" in the Check and Maintenance section.

- To check the belt tension, press the center of the belt with your thumb. If the deflection falls within the range specified in the following table, it is considered normal.

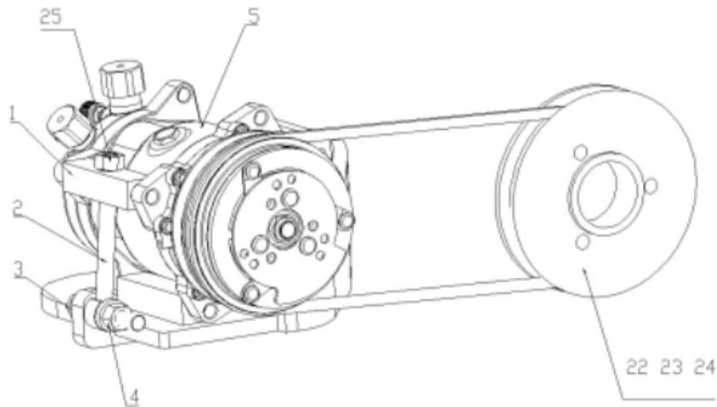

Belt	New belt tensioning mm	During checking mm	Pushing force N
Fans, alternators	5~8	7~10	98
Air conditioner belt	2.2	2.2	27~34 ※ New belt tensioning 13~17 ※ <b>During checking</b>

**Adjustment of alternator and fan belts**

**A Warning About belt check and maintenance**

Ensure the engine is turned off before performing any checks or maintenance.

Performing check or maintenance while the engine is running can result in being caught in rotating parts such as the belt or fan, leading to serious injury.

### Additional instructions

If the belt is not properly tensioned, it not only reduces alternator performance but can also cause damage to both the belt and the alternator.

1. Loosen the lower alternator mounting nut (1), the belt adjuster mounting bolt (2) and the belt adjuster fastening bolt (3).
2. Adjust alternator and fan belts to specified tension by turning adjusting bolt (4). Turn the adjusting bolt clockwise to tension.
3. After adjustment by the adjusting bolt (4), tighten the fastening bolt (3), belt adjusting mounting bolt (2) and mounting nut (1) in sequence.
4. After adjustment, run the engine at low idle for about 5 minutes or so after.
5. Turn off the engine and check the tension of the fan belt.
6. Release the support rod, and then close the hood.

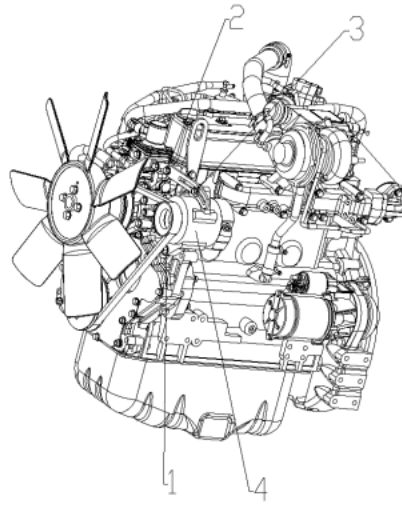

### Adjusting the tension of the air conditioner belt

#### A Warning About belt check and maintenance

Ensure the engine is turned off before performing any checks or maintenance.

Performing check or maintenance while the engine is running can result in being caught in rotating parts such as the belt or fan, leading to serious injury.

### Additional instructions

If the belt is not properly tensioned, it not only reduces compressor performance but can also cause damage to both the belt and the compressor.

1. Use the key and open the hood.
2. Slightly loosen the idler pulley nut, then turn the adjusting bolt, adjust the belt to the specified tension, and tighten the nut.
3. After adjustment, run the engine at low idle for about 5 minutes or so, then check the belt tension again.
4. Close the hood.

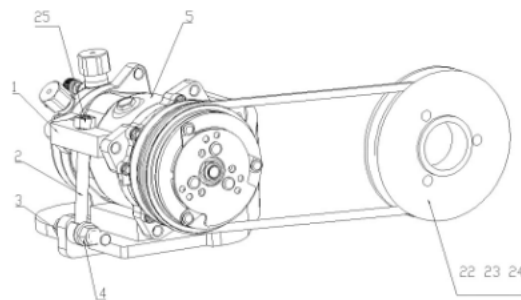

### 13.2 Check of rubber hoses in the air intake system

#### A Warning About the use of rubber hoses

- Do not touch the high-temperature area. Touching the high-temperature area during operation or just after shutdown may result in burns.
- When replacing the rubber hose, cover the air inlet with a clean cloth in order to avoid the ingress of garbage.

### Check of air filter suction rubber hose

1. Check the rubber hose 8 for damage and deterioration and the tie-down straps 1 for looseness.
2. Replace damaged or deteriorated rubber hoses with new ones together with the tie-down straps.

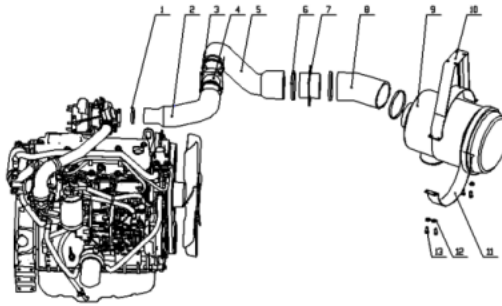

### 13.3 Water tank hose crack and damage check

#### A Warning Watch out for water tank hose damage

Replace the hose as soon as you notice it begins to crack, fray and leak. It prevents major malfunctions caused by engine overheating, etc.

#### Check of water tank hose

1. Use the key and open the hood.
  2. Check the clamp 3 of each hose for looseness and for leaks caused by cracks and abrasion of the hose (2).
  3. Retighten the loosened clamp 3.
- Replace the hose (2) that is cracked and deformed.

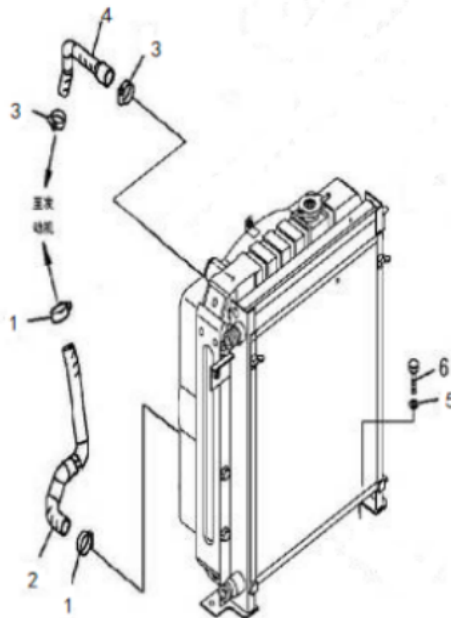

Direction view I

#### A Warning About water tank hose replacement

The water tank generates high-pressure steam, which poses significant dangers. Do not loosen or open the water tank cap while the cooling water is hot and under high pressure.

- Turn off the engine before opening the water tank cap.
- Wait until the cooling water cools down sufficiently.

1. Open the rear hood (1) with the key.

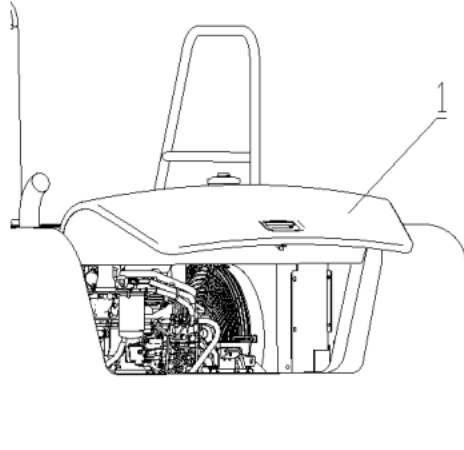

2. Slowly loosen the water tank cap to ensure pressure is released. Then, press in the cap and continue loosening and removing it gradually.

2. Insert the key to unlock and open the right side door. Then, open the discharge cock (3), allowing the cooling water to drain into a container. Continue draining until the water level falls below the replacement hose (4).

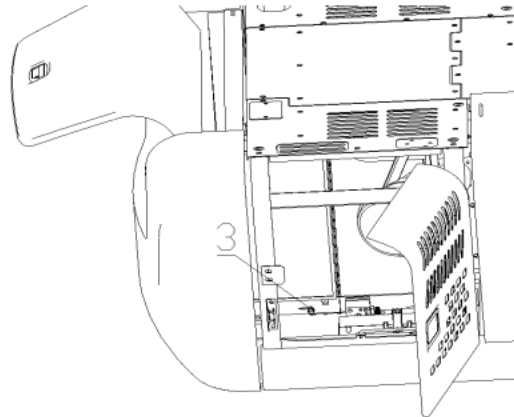

4. Loosen the clamp (2), remove the damaged hose (4) and replace it with a new hose.

5. Close the release plug (3), remove the support rod, and then close and lock the right side door using the key.

6. After filling the water tank with cooling water, make sure to also refill the reservoir.

7. After refilling, securely tighten the water tank cap.

8. Close the hood and lock it with the key.

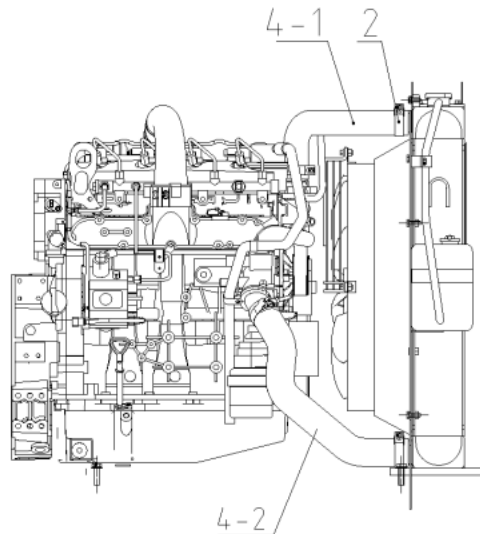

### 13.4 Check, cleaning and replacement of air filter elements

#### A Attention

- When using compressed air, wear goggles, a dust mask, and protective gloves.
- When cleaning or replacing the air filter element, make sure the engine is turned off beforehand.
- Do not remove the inner filter element except when replacing it.

- When replacing the inner filter element, cover the suction port inside the air filter with a clean cloth or tape to prevent trash from entering.

	Cleaning	Replace
Outer filter elements	When the display shows a warning Or every 250 hours	After 6 cleanings Or after 1 year
Inner filter elements		When replacing the outer filter elements

### Check and cleaning of the outer filter element

1. Open the side door on the right side of the body with the key and secure it with the support bar.

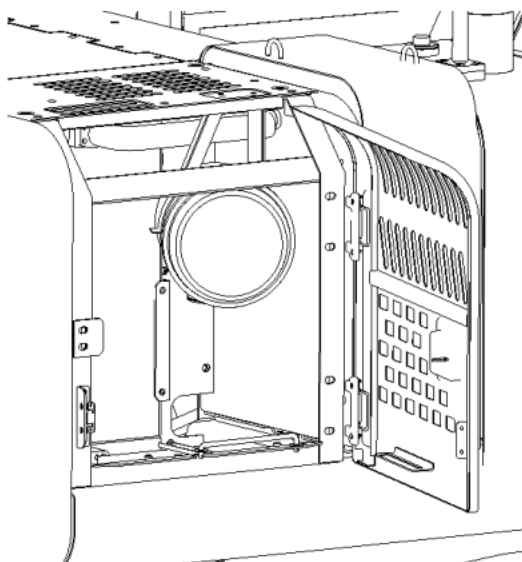

2. Remove the hose clamp of the air filter cover plate (1) to open it.  
3. Remove the outer filter element (2) and clean the inside of the air filter.

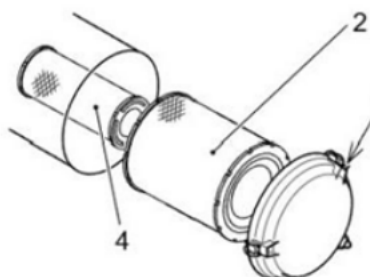

4. Blow compressed air of 0.2MPa or less along the filter paper, starting from the inside of the outer filter element (2). Then start from the outside and blow along the filter paper, after which start again from the inside.

Do not hit or knock the outer filter element with hard objects during cleaning.

5. After cleaning, check the outer filter element (2) and replace it with a new one if there are holes or cracks.

6. Remove the outer filter element (2).

7. When installing the cover plate (1) to the air filter, note that the arrow is facing up and secure it with a hose clamp.

8. Close the side door and lock it with the key.

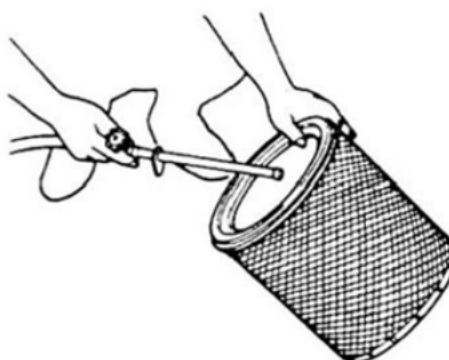

### Replacement of inner filter elements

When you replace the outer filter element, replace the inner filter element as well.

1. Remove the outer filter element (2).
2. Clean the inside of the air filter.
3. Remove the inner filter element (4).
4. Install a new inner filter element (4).
5. Install a new outer filter element (2).
6. When installing the cover plate (1) to the air filter, note that the arrow is facing up and secure it with a hose clamp.
7. Close the side door and lock it with the key.

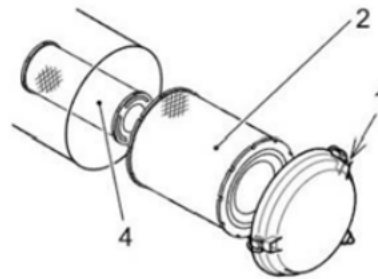

### 13.5 Water tank cap cleaning or replacement

#### A Warning About the use of cooling water and cover

Do not loosen or open the reservoir cap or water tank cap while the cooling water is at high temperature or high pressure. Otherwise, hot steam and cooling water spray may cause burns.

- To open the cover, wait for the temperature of the cooling water to drop and then turn it open slowly.
- Do not stick to your skin as antifreeze is toxic. If it splashes into your eyes or gets on leather garments, rinse immediately with plenty of water and seek medical attention.

#### A Attention

If open, close the cover effectively

Inspection and cleaning	Replace
Every 250 hours	When damaged or every year

1. Loosen the bolts (2 pcs) securing the plate (7), and open the plate (7).

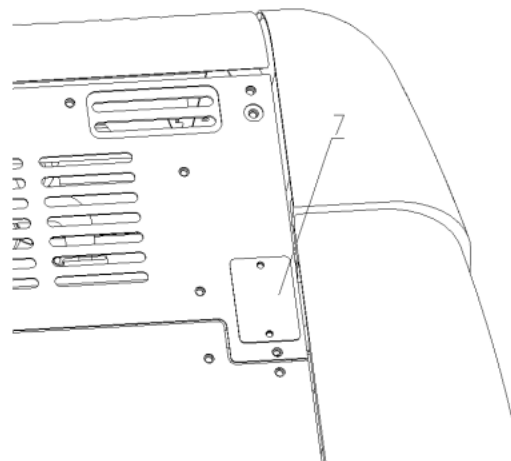

2. Please loosen the water tank cap (1) slowly to ensure pressure is released. Then, press the end cap and continue loosening it further to remove it.

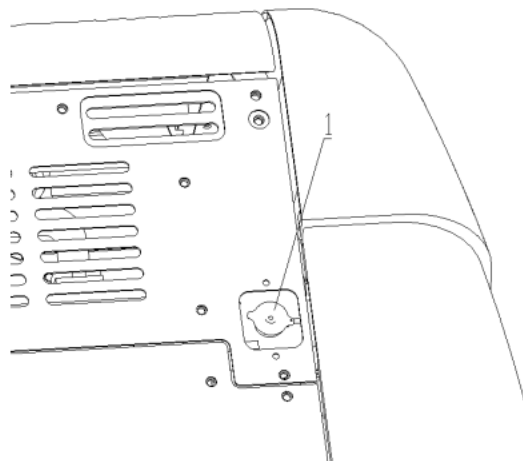

3. Check the following points on the cover. Clean the attached foreign matter and replace it if it is damaged.

A: Contact surface of negative pressure valve (2) and seal ring (5)

B: Both sides of pressure valve (3) and seal ring (5)

C: Both sides of the outer cover (4) and seal ring (6)

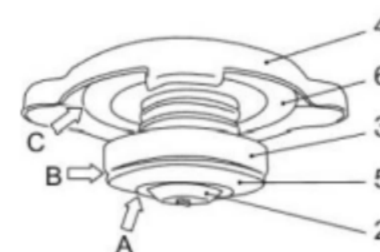

4. Close the water tank cover (1) and fasten the plate (7) with bolts.

### 13.6 Check and maintenance of batteries

#### A Warning About check and maintenance of batteries

This product uses a maintenance-free lead-acid battery that requires no special upkeep. For basic maintenance, you can refer to the battery schematic.

This location features a power indicator, which has three status displays located in the center area

Green: good condition;

Black: charging required;

White: surgery required to replace it.

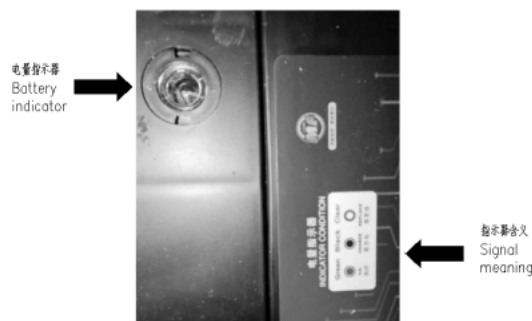

#### A Attention

Precautions for cold areas

- Pay sufficient attention to the insulation of the battery. If the temperature drops there is a danger of freezing and the capacity will be significantly reduced.
- Charge the battery as far in advance as possible.

### 13.7 Replacement of engine oil and engine oil filter

#### A Warning About the high-temperature area

- Touching the high-temperature area during operation or just after shutdown may result in burns. Do not touch the high-temperature area.
- The oil and oil filter are hot just after running. When replacing them, wait until the temperature drops before starting the operation.

#### A Attention

- Do not reuse the filter element, O-ring and seal ring.
- To avoid twisting or breaking of O-ring and seal ring, please confirm that they match with the assembly parts when replacing them.

#### Additional instructions

- Check the discharged engine oil, and contact the sales store of our company when iron pieces, iron powder, etc. are mixed in.
- Only add the engine oil for the first time. Please replace every 50 hours.
- When replacing the engine oil, replace the engine oil filter at the same time.
- When replacing the engine oil filter, run it at low idle speed for a few minutes until the oil fills the filter.

1. The oil drain is located at the position indicated in the image



2. Place a container for the discharged oil under the release plug (2). Container: 15L or higher

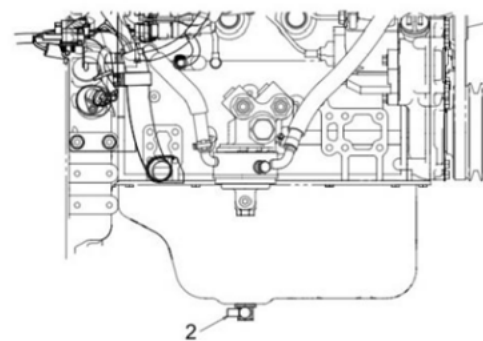

3. Clean the surrounding area of the oil filler cap (1), remove the protecting cover, loosen the release plug of engine oil pan (2), and discharge the oil.

4. After discharging the oil, securely tighten the release plug (2) and oil filler cap (1).

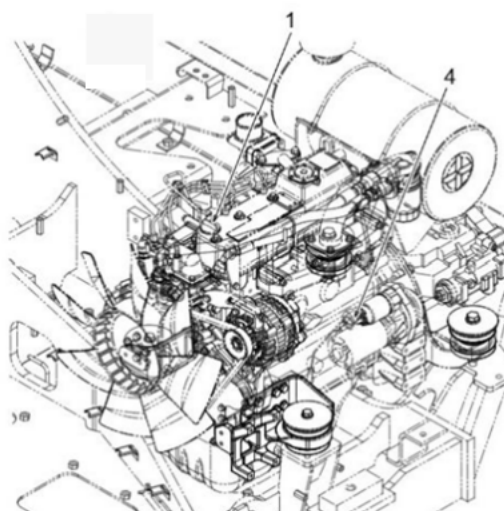

5. Remove the filter element (3) by turning it with a filter wrench.

6. Please remove stains and foreign matter from the mounting surface of the oil filter body.

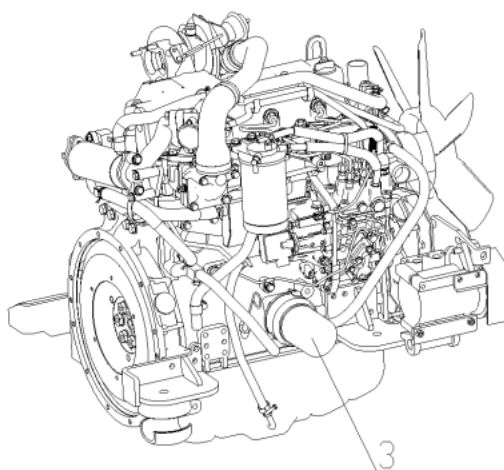

7. Apply engine oil to the seal ring of the new filter element. And then turn the filter element by hand and twist it until it won't turn.

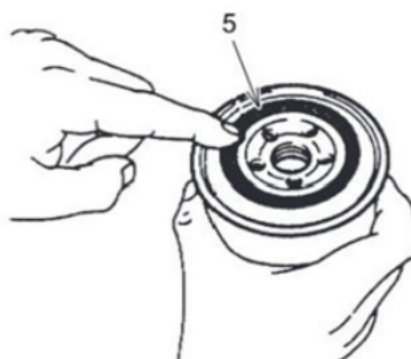

#### **A Attention**

- Do not reuse the filter element, O-ring and seal ring.
- To avoid twisting or breaking of O-ring and seal ring, please confirm that they match with the assembly parts when replacing them.

8. Please use a filter wrench and tighten for 1 round.

9. Remove the oil filler cap and fill the specified engine oil from the oil fill port with reference to "Recommended Oil Viscosity and Replacement Capacity" in Chapter 4.

10. To fill the proper amount of engine oil, please check with the level gauge (4) and fill to the

level between the upper (H) and lower (L) limits.

11. Please assemble the oil filler cap (1).
12. Start the engine and run it at low idle speed for a few minutes, and then turn off the engine. Check the oil amount in the engine after about 10 minutes. If it is insufficient, refill the engine oil again until the amount is suitable.
13. Please check the oil filter assembly surface for oil leakage.
14. Please install the cover plate (6) under the engine back to its original position.

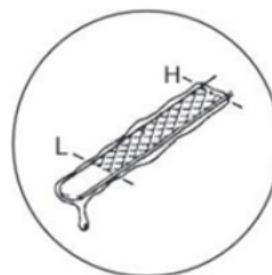

### 13.8 Oil-water separator replacement

#### A **Warning** About the use of fuel

- Spilled fuel can cause a fire, so wipe it up thoroughly.
- After operation, please confirm there are no fuel leaks.

1. Please stop the engine, open the rear hood and support it with the support rod.
2. Rotate to remove the cartridge.
3. Please wipe the sealing surface of the filter base clean. There shall be no trash or foreign matter.
4. Please apply a thin layer of clean diesel to the sealing gasket part of the new cartridge, tighten it by hand, and then tighten it by about 2/3 turns.
5. Please exhaust air with reference to the item "Air Exhaust of Fuel Piping".
6. Please apply a thin layer of diesel to the new O-ring and install it on the filter housing core.
7. Please exhaust air with reference to the item "Air Exhaust of Fuel Piping".
8. Please start the engine. After a few minutes of idle running, confirm that there is no fuel leakage from the oil-water separator mounting part.



### 13.9 Replacement of fuel filter

#### A **Warning** About the use of fuel

- Shortly after the engine is shut down, all parts are hot. Please operate after each part has cooled down.
- Spilled fuel can cause a fire, so wipe it up thoroughly.

### Additional instructions

The fuel filter is of cartridge type and is not reusable.

1. Please stop the engine and open the rear hood.

2. Use the wrench supplied with the machine for installation and removal of fuel filter and remove the cartridge (1) by turning it to the left (A).

3. Please wipe the sealing surface of the filter base clean. There shall be no trash or foreign matter.

4. Please apply a thin layer of clean diesel to the sealing gasket part (A) of the new cartridge, tighten it by hand, and then tighten it by about 2/3 turns.

5. Please exhaust air with reference to the item "Air Exhaust of Fuel Piping".

6. Please start the engine. After a few minutes of idle running, confirm that there is no fuel leakage from the filter mounting part.

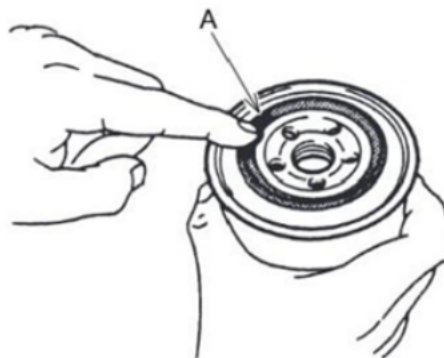
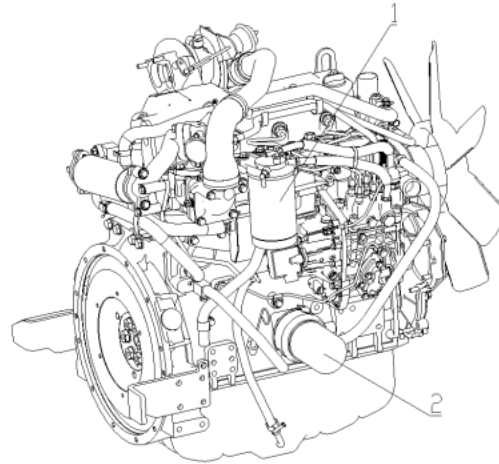

### 14 Maintenance every 500 hours (or 6 months)

Carefully review the "Safety" section of this manual and ensure a thorough understanding before conducting any operations, checks, or maintenance.

In addition to this item, please also implement "check before work", "maintenance every 50 hours", "maintenance every 100 hours", and "maintenance every 250 hours".

#### 14.1 Replenish grease to the swivel bearing.

##### A Warning About filling grease to the swivel bearing

When filling grease to the swivel bearing, to avoid danger, do not turn while adding oil.

There is 1 grease fitting.

- Please clean the grease fitting and fill grease once when the upper swivel body is rotated for 90°.

Regarding the amount of grease to be filled, fill grease in each direction of the upper swivel body to the extent that it flows out of the seal of the bearing.

(Up to about 35cc in each direction)

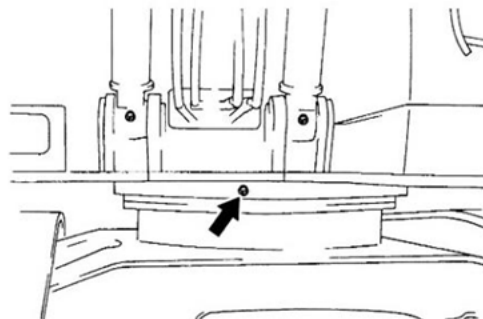

#### 14.2 Loose check of swivel bearing assembly bolts

##### Additional instructions

Please use a torque wrench to tighten the swivel bearing.

1. Check whether bolts (1) and (2) that fasten the swivel bearing are loose.
2. If they are loose, please first remove bolts (1) and (2), apply recommended adhesive (Loctite #262 or equivalent), and tighten.

Cross-tighten the bolts in the diagonal order.

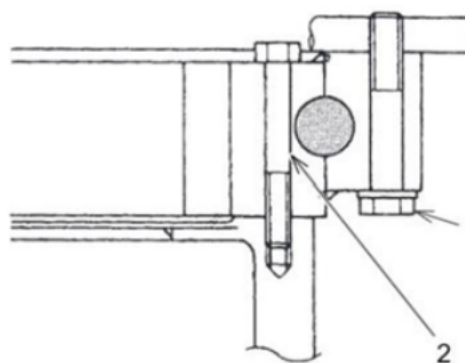

Assembly parts	Tightening torque N · m
Inner ring	279±29
Outer ring	157±16

### 14.3 Cleaning of fuel tank, protecting cover and filter mesh

1. Please stop the engine.
2. If there is a rubber cap (2) on the filling port, please use the start key and turn the oil filler cap (1) to open it.
3. Check the seal of the filler cap (1) and replace it if it is damaged.
4. Please wash the filter mesh (3) clean with clean diesel and install it. Replace it if it is damaged.
5. Please assemble the filler cap (1), lock it with the start key, align the rubber cap (2) to the fuel filler cap (1), and install.

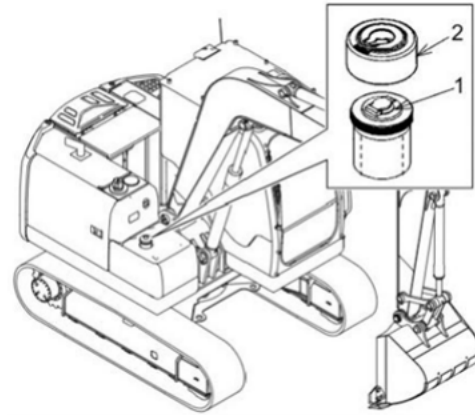

### 14.4 Replenishment of grease in the push rod part of the operating lever

1. Please press down Part A of protective cover (3), remove the first 2 of the 4 clips (b) from the resin cover plate (4), and then remove the protective cover (3).

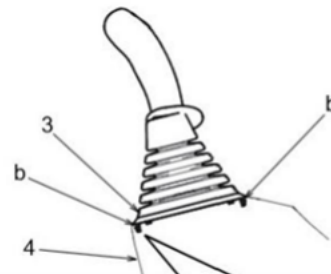

2. Please remove the protective cover of the pilot valve and apply a small amount of grease to the push rod (1) and the apex of the rotating sliding part (2).
3. After applying grease, please first install the protective cover of pilot valve and protective cover (3).

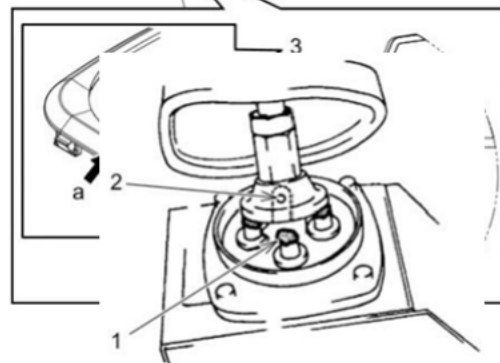

#### **14.5 Check the amount of refrigerant of the air conditioner.**

##### **A Warning About refrigerant**

- If liquid from the air conditioner refrigerant splashes in your eyes or comes into contact with your hands, it may cause blindness or frostbite. Therefore, do not release the parts on the refrigerant circuit.
- Inhaling refrigerant gas can be fatal to the human body. In addition, keep away from any sources of ignition in places where refrigerant gas is generated.

##### **Additional instructions**

- When replenishing or replacing the refrigerant, use the specified product after checking the type of refrigerant.

(Refrigerant type: R-134a Capacity: 780g±50g) Use of refrigerant other than that specified refrigerant may damage the machine.

- Even in a season when you should not use air conditioner, please run the air conditioner at least once a week regardless of the season. Make the air conditioner operate for a few minutes at a time to allow the compressor to rotate. This can prevent leakage of refrigerant gas from the sealing part of the compressor.
- When oil oozes out of the pipe fitting, air leakage may occur. Please have it checked by sales store of our company.

##### **Additional instructions**

In order to protect the environment of the earth, the law stipulates the following matters, which must be followed:

- Do not freely release the refrigerant sealed in this product to the atmosphere.
  - When disposing of this product, please recover the refrigerant sealed in it.
1. Please start the engine and set the engine speed to the medium position of the throttle adjustment knob.
  2. Please close the doors and windows of the cab.
  3. Please set your air conditioner according to the following requirements:
    - (1) Air conditioner control: O
    - (2) Air volume switching switch: 0 L M H
    - (3) Temperature setting switch: COOL, the coldest
  4. Please observe the observation window (check window) (5) and confirm the refrigerant amount.

Please refer to the chart "Judgment of Refrigerant Amount Observed from the Observation Window" for the basis of judging the filling amount of refrigerant.

##### **Additional instructions**

Please refer to "Operation and Use of Air Conditioner" above for detailed operation and principle.

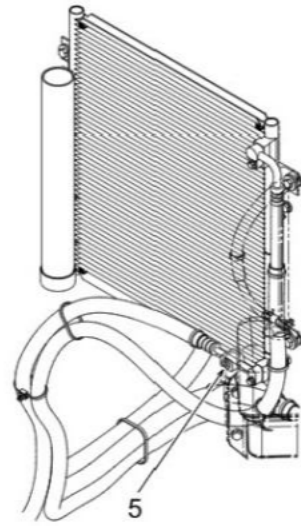

## 15. Maintenance every 1000 hours (or 12 months)

Carefully review the "Safety" section of this manual and ensure a thorough understanding before conducting any operations, checks, or maintenance.

In addition, perform the "Check Before Starting Operation and Perform Maintenance every 50 hours, 100 hours, 250 hours, and 500 hours" concurrently.

### 15.1 Ventilation valve filter element replacement

#### A Attention

Shortly after the engine is started, the working oil is hot and there is a danger of burns. Please wait until the oil temperature has dropped.

#### Additional instructions

- To keep the working oil clean and prolong the service life of the hydraulic equipment, please replace the filter element regularly.
- Replace every 1,000 hours as the approximate standard. Please replace it earlier in case of sandy or dusty site, etc.

1. Move the machine to a sturdy and level place.
2. Please let the bucket touch the ground.
3. Please stop the engine and place the lifting hydraulic locking lever in the locked position.
4. Please remove the air exhaust valve cover (1) on top of the working oil tank and press the valve to release the pressure in the working oil tank.
5. Please remove the bolt (8) on the oil tank.

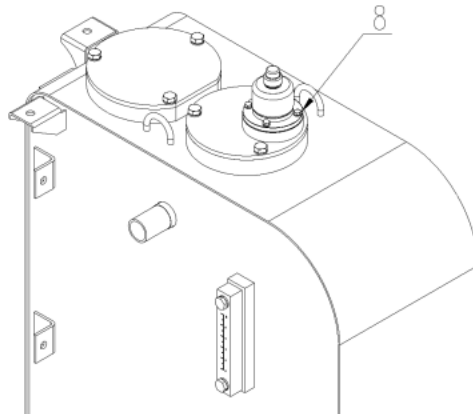

6. After removing the air exhaust valve cover (1), please remove in the order of the seal (2), nut (3), and seal (4).
7. Turn the cover plate (5) similarly in an anti-clockwise direction to remove it. Please remove the filter element (6).
8. Please install a new filter element (6), align the cover plate (5) to the slot and install.
9. Please note that water or trash should never be allowed to enter the space between the cover plate (5) and the body (7) (air suction and exhaust ports).
10. Please install the seal (4) on the cover plate (5), assemble the nut (3) and set the seal (2).

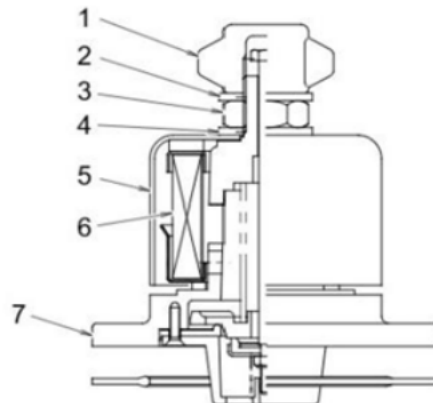

**A Attention**

Note that it can sometimes cause the breaking of bolt if the nut (3) is over-torqued. Tightening torque: 10~14Nm

11. Please turn the air exhaust valve cover (1) clockwise by hand and tighten it securely.

## 15.2 Replacement of rotary reducer oil

### A Warning About oil treatment just after running

Just after running, the oil is hot and there is a danger of burns, wait until the temperature drops before starting the operation.

### Additional instructions

This equipment utilizes hydraulic oil as its lubricant, eliminating the need for additional grease lubrication.

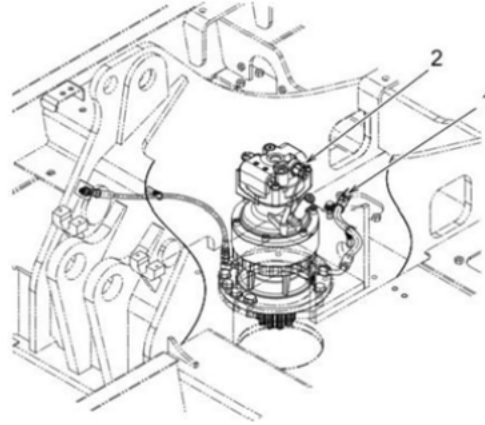

## 15.3 Replacement of oil of the traveling reducer

### A Warning About oil treatment just after running

- Just after running, the oil is hot and there is a danger of scalding. Wait until the temperature drops before starting the operation.
- Sometimes there is residual pressure inside the driving unit. Please slowly loosen the plug to release the pressure.

### Additional instructions

Only add the engine oil for the first time. Please replace every 500 hours.

### Additional instructions

- Check the discharged oil, and contact the sales store of our company when foreign matters such as iron pieces and iron powder are mixed in.
- Please dispose of the discharged waste oil properly as industrial waste.

1. Move the machine to a sturdy and level place.
2. Stop the machine with the drain plug (1) on the lower side so that the bucket touches the ground.
3. Please stop the engine and place the lifting hydraulic locking lever in the locked position.
4. Please place a container for the discharged oil under the drain plug (1). Container: Container of 1.35L×2 or above
5. Please remove drain plug (1) and level plug (2) and filler plug (3), and discharge oil into a container.

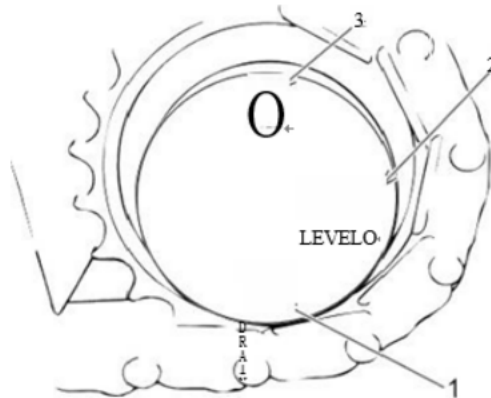

6. After the oil is fully drained, please wash the drain plug (1) with diesel and assemble the plug.

7. Please fill the specified gear oil from the hole part of the filler plug (3) until the oil flows out of the level plug (2).

For the specified gear oil, refer to "Recommended Oil Viscosity and Replacement Capacity".

8. Use diesel oil to clean the level plug (2), the filler plug (3), and then install.

9. Please also replace the oil of the other traveling reducer.

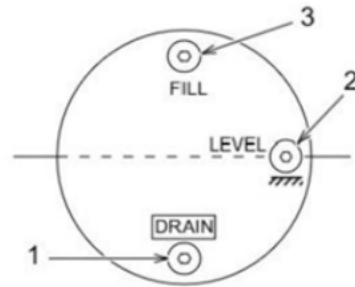

### 15.4 Filling grease to the rotary reducer

#### A Warning About the operation just after running

Just after running, the parts are hot and there is a danger of burns. Wait until the temperature drops before starting the operation.

#### Additional instructions

This equipment utilizes hydraulic oil as its lubricant, eliminating the need for additional grease lubrication.

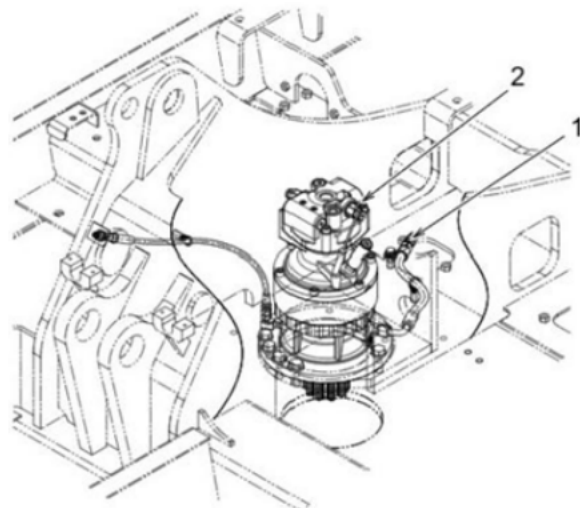

### 15.5 Inspection of rotary bearing lubrication grooves

#### Additional instructions

This equipment utilizes hydraulic oil as its lubricant, eliminating the need for additional grease lubrication.

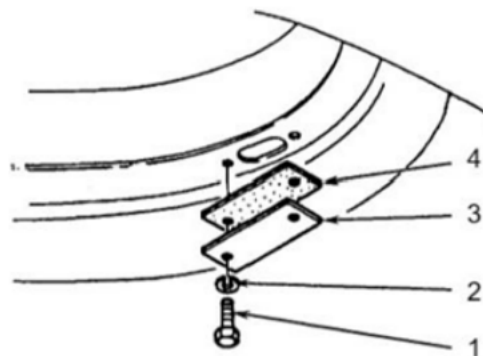

## 15.6 Battery voltage check

### A **Warning**      **About the use of battery**

- Wear goggles, a long-sleeved shirt, and gloves when using the battery.
- The battery poses a risk of generating flammable hydrogen gas and exploding, so it must be kept away from any sources of ignition.
- Dilute sulfuric acid from batteries can cause burns or blindness upon contact with skin or eyes. In case of accidental contact with the skin or eyes, wash with clean water and receive professional medical attention.
- When maintaining and checking the battery, be sure to stop the engine first and set the battery power disconnect switch to OFF.
- When removing the battery terminals, be sure to start with the ground side (terminal-). When installing, do the reverse, connecting the ground side last.
- Do not place tools and metal objects on the protective cover plate in the upper part of the battery. There is a risk of short-circuit fires and explosions.

### A **Additional instructions**

- Do not use the battery power cutoff switch for purposes other than those described in this instruction manual. Never turn the switch to [0(OFF)] during engine rotation.

To adjust the battery power cutoff switch to [0(OFF)], please turn the battery switch off and operate after an interval of 1 minute or more.

Otherwise, there may be a risk of damage to the electronic equipment.

- When the switch is adjusted to [OFF], all electrical circuits are disconnected, and the radio's pre-programmed memory and clock memory will be cleared.

### **Additional instructions**

- Clean the battery terminals and apply grease or commercially available anti-rust lubricant spray.
  - Do not dispose of the battery at will, and be sure to have it disposed of by a professional manufacturer.
  - Do not mix old and new batteries when the battery is old. Otherwise, it will shorten the life of the new battery. When replacing the batteries, ensure that you replace both of them.
1. Please measure the voltage of the battery. Please charge or replace it when the specified voltage is not reached.
  2. After replacement, please secure the battery properly to the machine.

## 16 Maintenance every 2,000 hours

Carefully review the "Safety" section of this manual and ensure a thorough understanding before conducting any operations, checks, or maintenance.

In addition, perform the "Check Before Starting Operation and Perform Checks and Maintenance every 50 hours, 100 hours, 250 hours, 500 hours and 1000 hours" concurrently.

### 16.1 Replace the oil return filter

#### A **Warning** Pay attention to the high-temperature area

- The working oil tank contains high-temperature and high-pressure oil, which is very dangerous.

When removing the cover plate, turn off the engine, remove the air exhaust valve cover, and press the valve to release the pressure in the oil tank.

- Just after running the engine, the oil is hot and there is a danger of burns. Please wait until the temperature drops.

#### **Additional instructions**

Inside the filter, the working oil before filtering contains trash. When removing the oil return filter, do not allow any working oil remaining inside the filter to flow back into the oil tank.

#### **Additional instructions**

- When ordering the oil return filter element kit to be replaced, please confirm the part number with sales store of our company.

In addition, replace the oil return filter every 2,000 hours. Please replace the breaker hammer specification every 1000 hours.

- Not only when the maintenance time remaining set in the display changes to 0 but also when the oil return filter is blocked, a warning is shown on the display.

Regardless of the set time for maintenance, if a warning to replace the hydraulic oil filter is displayed, please replace the oil return filter.

1. Move the machine to a sturdy and level place.
2. Please keep the machine in the working oil level check position.
3. Please stop the engine and place the lifting hydraulic locking lever in the locked position.

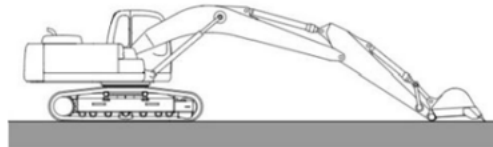

4. Please remove the air exhaust valve cover (1) on top of the working oil tank and press the valve to release the pressure in the working oil tank.

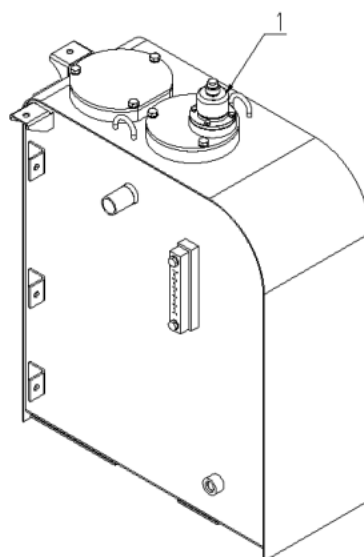

5. Remove the bolts (2), washers (3), and the cover plate (4) from the top of the oil tank.  
6. Remove the spring (6) and the filter element assembly (7) from the oil tank.

At this time, do not allow the working oil remaining in the filter to flow back into the oil tank.

7. Please the O-ring (6) on the assembly surface of the cover plate (4).

8. Please insert the filter element assembly (7).

9. Put in the spring (6) and press it firmly with the cover plate (4).

10. Please assemble the cover plate (4) with the bolts (2) and washers (3). Tightening torque:  $46.5 \pm 4.6 \text{ N}\cdot\text{m}$

11. Please start the engine, place it in the working oil level check position, and check the working oil level.

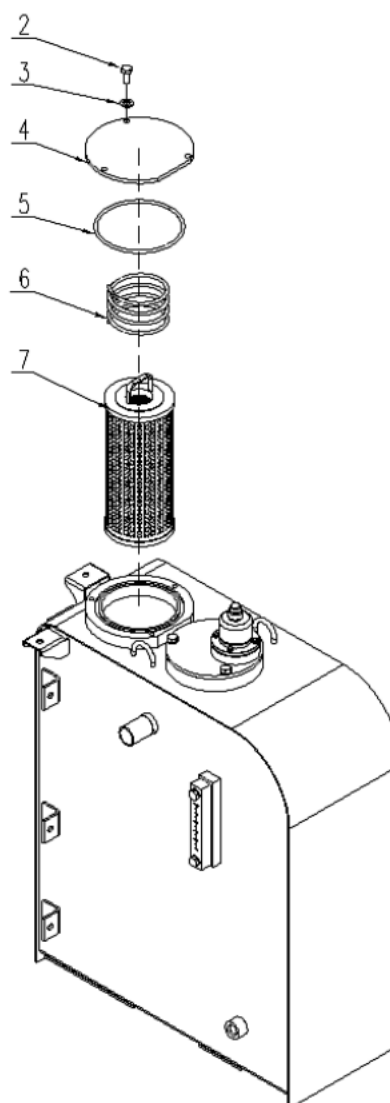

## 16.2 Replacement of cooling water

### A **Warning** About the use of cooling water

Do not loosen the water tank cover or open it when the cooling water is in the state of high temperature and high pressure. Otherwise, hot steam and cooling water spray may cause burns.

- When opening the water tank cover, please wait until the temperature of the cooling water drops before slowly turning and opening it.
- Be careful not to get antifreeze on your skin as it is toxic. In the event of splashing in the eyes or adhering to the skin, rinse immediately with plenty of water and seek medical attention.

### A **Attention**

If air is trapped in the cooling water circuit, it may cause the breaking of the machine. Please operate according to the steps and prevent air from being trapped in the cooling water circuit.

### **Additional instructions**

Please use pure antifreeze at the concentration of 50%. Please mix clean water such as tap water with antifreeze.

- Please use the specified antifreeze. If you use an inappropriate antifreeze, it can lead to machine failure such as rust in the cooling water circuit.
- Do not use different types of coolant together.
- Please replace the cooling water as soon as possible after it becomes dirty or foams.

1. Please move the machine to a firm and level place with the bucket touching the ground.

2. Please stop the engine and place the lifting hydraulic locking lever in the locked position.

3. Please loosen the water tank cap (1) slowly to ensure pressure is released. Then, press the end cap and continue loosening it further to remove it. This is the water filling nozzle of the water tank.

4. Placing the container for draining at the waterproof port under the radiator, open the discharge cock (3) for draining.

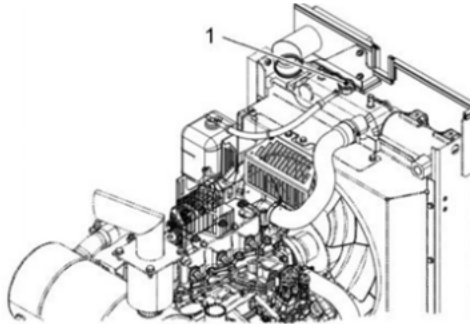

5. After draining, please close the discharge cock (3), and add new coolant with a hose from the filler of the radiator.

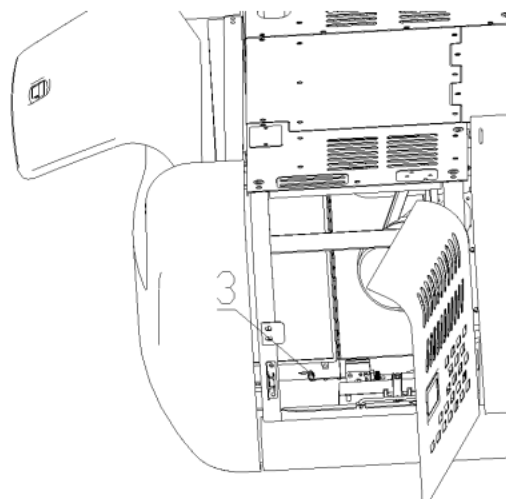

13. Please fill water from the water filling nozzle of the water tank until the cooling water is full and reaches the mouth.

In this case, to avoid air mixing as much as possible, please fill the water slowly. (The water filling rate is 4L/min.)

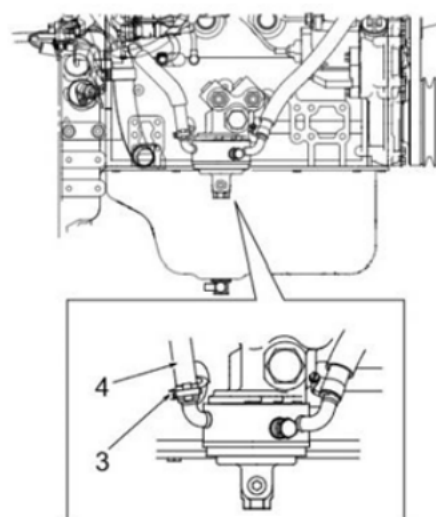

14. To exhaust air from the cooling water circuit, please start the engine and run it on standby at low idle speed for 5 minutes and high idle speed for 5 minutes. In this case, please remove the water tank cover (1) first.

15. Please stop the engine. After about 3 minutes, fill cooling water from the water filling nozzle of the water tank until the water level is full and reaches the mouth. And then, close the water tank cover.

16. Please fill the reservoir with cooling water until the water level is in the middle of FULL (upper limit)-LOW (lower limit).

17. Please install the lower cover plate under the water tank.

18. Please check the level of the water filling nozzle of the water tank and the level of the reservoir after the cooling water has cooled sufficiently.

- If the level of the water filling nozzle of the water tank drops, please fill it with water.

Please fill the reservoir with water until the level is in the middle between FULL (upper limit) and LOW (lower limit).

### 16.3 Cleaning of pilot oil circuit filter

#### A Attention

Just after running, hot working oil sprays out and there is a danger of burns.

Please wait until the oil temperature has dropped.

Please implement after releasing the internal pressure of the working oil tank and hydraulic system.

1. The filter is located here as shown in the figure. You have the option to remove either the entire valve block along with the filter or just the filter itself, as demonstrated in the image below.

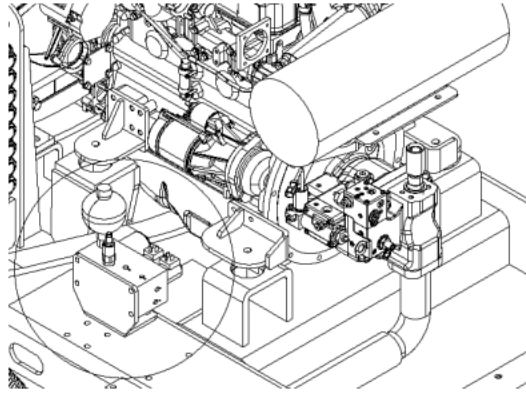

2. Rotate to remove filter (1), clean it, and then refit it back in place.

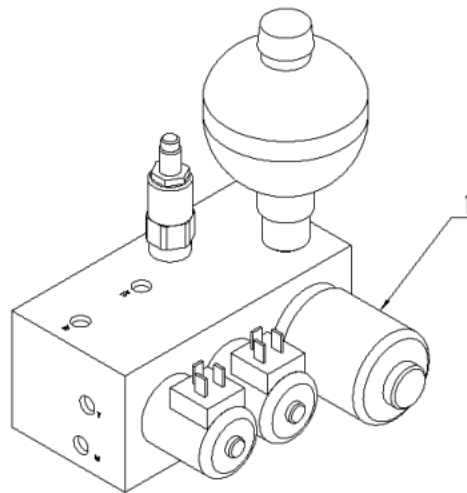

### 17 Maintenance every 5,000 hours

Carefully review the "Safety" section of this manual and ensure a thorough understanding before conducting any operations, checks, or maintenance.

In addition, perform the "Check Before Starting Operation and Perform Maintenance every 50 hours, 100 hours, 250 hours, 500 hours, 1000 hours and 2000 hours" concurrently.

#### 17.1 Replacement of working oil and washing of suction filter mesh

##### A Warning About the disposal of working oil tank and oil

- The working oil tank contains high-pressure and high-temperature oil and is therefore hazardous. When removing the cover, please press the breather after stopping the engine to discharge the pressure in the tank.
- Just after running the engine, the oil is hot and there is a danger of burns. Please wait until the temperature drops.

#### Additional instructions

When a hydraulic breaker hammer is equipped, the working oil deteriorates significantly compared to normal bucket digging operation. Therefore, please maintain with reference to the item of "Periodic Check and Maintenance of Hydraulic Scissors and Breaker Hammer".

**Additional instructions**

Please dispose of the discharged waste oil properly as industrial waste.

1. Move the machine to a sturdy and level place.
2. To position the drain plug (1) in the lower part of the working oil tank in the middle of the right and left track plates, please turn the upper swivel body.
3. Retract the arm cylinder and bucket cylinder so that the bucket and dozer blade (loader only) are in contact with the ground.
4. Please stop the engine and place the lifting hydraulic locking lever in the locked position.
5. Please sweep around the cover plate to prevent foreign matter from entering the working oil tank.

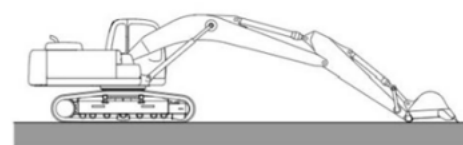

6. Please remove the air exhaust valve cover (2) on top of the working oil tank and press the valve to release the pressure in the working oil tank.

7. Remove the bolts (6) (8), washers (7) (9), and the cover plate (2) from the top of the oil tank.

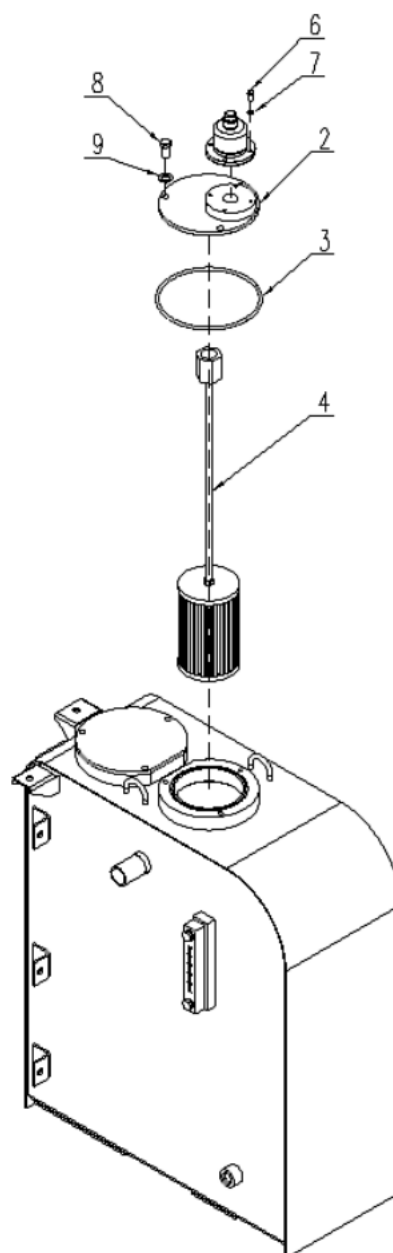

#### **Additional instructions**

Do not drop bolts, etc. into the oil tank.

8. Please place a container for the discharged oil under the drain plug (1) under the working oil tank.

9. Please slowly loosen the drain plug (1) and drain the working oil completely.

10. Wash the drain plug (1) and tighten it to its original position. Tightening torque:  $108 \pm 10 \text{N}\cdot\text{m}$

11. Please remove the suction filter mesh (4).

12. Please wash the suction filter mesh (4) with clean diesel or detergent and check the filter mesh after it is thoroughly dry. When there is a big damage to the surface, please replace it with a new product.

L:823±1mm

13. Check the O-ring at the bottom of the filter mesh (5) and O-ring (7). Replace them if they are worn or damaged.

14. Please insert the suction filter mesh (4) into the working oil tank.

15. Add oil from the filling port at the top of the working oil tank.

Please check the oil level at the time of filling oil with the level gauge (G) while filling oil.

16. Assemble the oil port cover (2) with the bolts (8). Tightening torque:  $46.5\pm 4.6\text{N}\cdot\text{m}$

17. Start the engine and run it at low idle speed for a few minutes (5 to 7), then make the extending-retracting and rotating operation of each cylinder.

18. Please allow the machine to return to the working oil level check position, turn off the engine, and check the oil amount. When it is insufficient, please replenish the working oil.

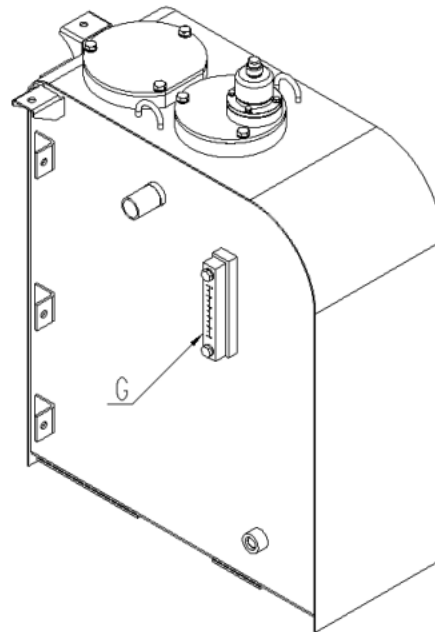

## 17.2 About maintenance of working machine in harsh environments

Machines working in harsh environments are generally defined as machines that operate under the following operating conditions.

- Machines that work in environments that are always dusty
- Machines that work continuously at high loads for a long time
- Machines whose engine is continuously idling at a low speed for a long time
- Machines whose engines are often idling
- Machines whose engines start and stop repeatedly and frequently
- Machines that still have failures even with standard maintenance

For machines working in harsh environments, measures such as shorter maintenance intervals shall be taken.

### Recommended maintenance for machines working in harsh environments

#### Additional instructions

Please refer to the "Check and Maintenance Checklist" for standard maintenance intervals.

Item	Recommended maintenance
Checking the amount of engine oil	<b>Pre-operation checks</b>
Engine oil	Chemically synthesized oil (high-performance oil)
Replacement of engine oil	Replace it every 250 hours
Replacement of engine oil filter	Replace simultaneously with engine oil
Replacement of fuel filter	Replace it every 250 hours
Replacement of the primary fuel filter/water separator	Replace every 250 hours
Cleaning of engine combustion chamber	Please wash with special fuel additive every 1,000 hours or 12 months.
Air filter element (external)	Cleanup before start of operation
	Replace it every 250 hours
Air filter element (internal)	Replace simultaneously with the external element (no cleaning)

### **Starting and stopping of the engine**

Please start operation after warm running.

At the end of the operation, do not operate the control lever for 5 minutes. Please stop the engine after turning the engine to low-speed idle.

### **Method of application during running**

If the engine is idling at low speed and there are a lot of low-load operations, periodically turn the engine to high idle for high-load operation.

## 18 Maintenance and description of use of machines with rubber track plates

### 18.1 Description of rubber mat track plate and road liner

Rubber mat track plates and road liners offer excellent properties not found in metal track plates. However, if they are used in the same way as metal track plates, their advantages are not fully utilized.

Operate in a manner suitable for the conditions of the work site and the nature of the work without deformation of the rubber track plate.

#### Comparison of track plates

	Rubber track plate	Road liner	Metal track plate
Small vibration	Excellent	Excellent	Average
Stable traveling (no rolling sound)	Excellent	Good	Good
Low noise	Excellent	Excellent	Average
No damage to paved road surface	Excellent	Excellent	Average
Convenient to use	Excellent	Average	Average
Resistant to damage	Average	Good	Excellent
High traction	Excellent	Excellent	Excellent

Rubber track plates and road liners have a variety of advantages considering the properties of the material used. However, their weakness is that they are not strong enough. Therefore, it is important to understand the advantages of rubber track plates and road liners and observe the precautions regarding operation and prohibited operation. This will extend the service life of rubber track plates and road liners and allow the machine to fully show the advantages of rubber track plates and road liners. Before using rubber track plates and road liners, read "Use Rubber Track Plates and Road Liners"

### 18.2 Warranty on rubber track plates and road liners

The track must be checked and maintained so that it has the proper tension. In addition, these track plates must not be used near objects that can damage the track plate, such as edges and corners of steel plates, U-grooves, material blocks, gravel or stones with sharp corners, iron rods, or scrap iron.

Any damage caused by the user's incorrect use of the machine will not be covered by the warranty.

### 18.3 Use rubber track plates and road liners

#### Prohibited operations

Do not perform the following types of operations.

- Operating and steering on gravel, extremely rough hard rocks, and sharp corners of I-beams, scrap iron or steel plates can cause damage to rubber track plates and road liners.
- In places such as riverbeds with a large number of big and small pebbles, stones can squeeze in them and damage rubber track plates and road liners or make the track plate fall off. If the bulldozing operation is performed when the track plate is slipping, the service life of the rubber track plate and road liner will be shortened.
- Do not get oil, fuel or chemical solvent on the rubber track plate and road liner. If this

substance gets on the track plate, remove it immediately. Besides, don't travel on the oily road surface.

- When the machine is stored for a long time (three months or more), store the machine indoors to protect it from sun and rain.
- Do not use the machine in hot areas, such as where there is burning wood, on the steel plate exposed to the hot sun or where asphalt has been paved.
- Do not move the machine with one side of the track lifted by the working device, as this can damage the rubber track plate and can make it fall off.
- Replace the track plate immediately when the rubber parts of the road liner are worn or damaged or when the heads of the mounting bolts are scratched. If the head of the bolt breaks, it will be difficult to remove.
- When installing the road liner, be sure to install the liner on all chain links on both sides. If it is only installed on some of the chain links, its durability will be significantly reduced.

#### **Extended service life**

During work, please observe the following points.

- Avoid turning in place on the concrete pavement.
- Avoid sudden changes in travel direction, which can prematurely wear or damage rubber track plates and road liners.
- Avoid steering of the operation when passing through a place with a big difference of level. When crossing an obstacle or place with a big difference of level, the machine shall cross the obstacle in a straight line to prevent the track plate from falling off.
- If the machine has been lifted with the bucket, drop it slowly.
- Avoid operating on substances that produce oil when squeezed (beans, cereals or vegetables containing oil); or rinse the machine after use.
- Avoid operating on substances that destroy the adhesion of the steel core, such as salt, ammonium sulfate, potassium chloride, potassium sulfate or calcium superphosphate, or rinsing the machine after use.
- Salt will destroy the adhesion of the steel core. Therefore, avoid operating in beach areas.
- When operating on salt, sugar, wheat or beans, these substances can get into the raised or scratched parts of the rubber if the rubber track plate and road liner has deep scratches. Repair the rubber mat before use.
- Do not perform operation that involves scraping of walls or concrete embankments.
- Rubber track plates and road liners may slip easily on snowy or frozen roads. Do not slip when traveling or operating on slopes.
- The properties of rubber track plates and road liners will change when operating in extreme cold places. This can shorten the service life of rubber track plates and road liners.
- Due to the properties of rubber, use rubber track plates in the range of -25°C - 55°C (-13°F - 131°F).
- Due to the properties of rubber, use road liners in the range of -25°C - 65°C (-13°F - 149°F).
- When performing bucket operation, note that rubber track plates and road liners shall not be damaged by the bucket.
- Be sure to keep the proper tension of the rubber track plate to prevent it from falling off.

If the tension is low, the rubber track plate will fall off under the following conditions.

1. Avoid operating the steering when crossing curbs, stones, or areas with a big difference of level (greater than 20 cm (8 in)). When crossing such obstacles, travel at right angles to the obstacle.

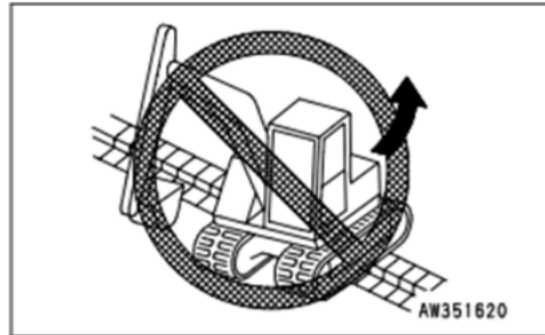

2. When backing up a slope, do not turn while moving from flat ground to the slope. If you must turn on a slope, always turn slowly.

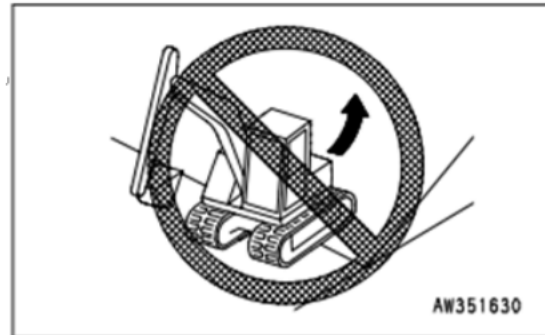

3. Avoid traveling along the edge of a slope or on uneven ground so that one side of the track is raised (the machine tilts more than 10°) and the other side of the track is on flat ground. To avoid damage to the rubber track plate and road liner, travel with tracks on both sides on the level ground.

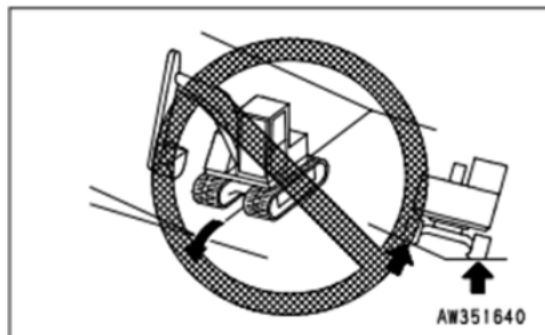

4. If the machine is operated as described in 1 to 3 above, the rubber track plate will become loose. Do not allow the machine to turn in the position shown in the picture.

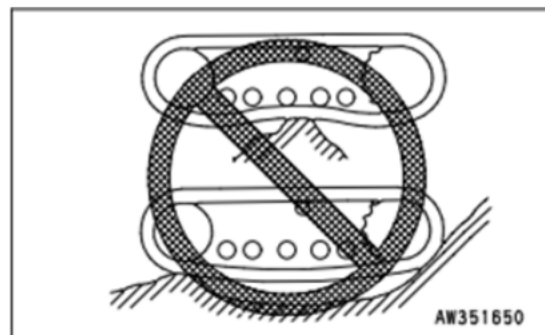

Principle of falling off of the rubber track plate

1) When traveling over obstacles, a gap is formed between the track roller and the rubber track plate. In this case, the rubber track plate will fall off.

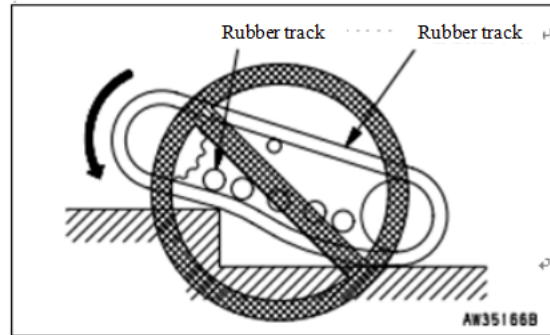

2) In addition, if the machine travels reversely, a gap will be formed between the track roller, guide wheel and rubber track plate.

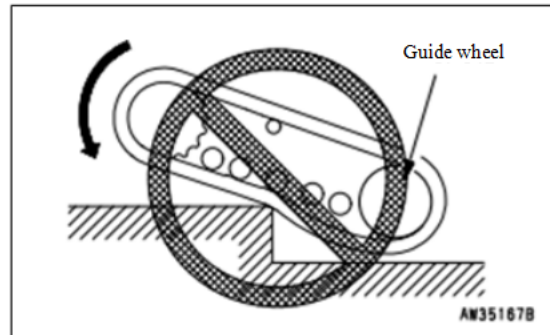

- When the rubber track plate turns because it crosses an object or cannot be moved to the side for another object.
- When the rubber track plate is no longer in a straight line and either the guide wheel or the track roller is not aligned with the center.

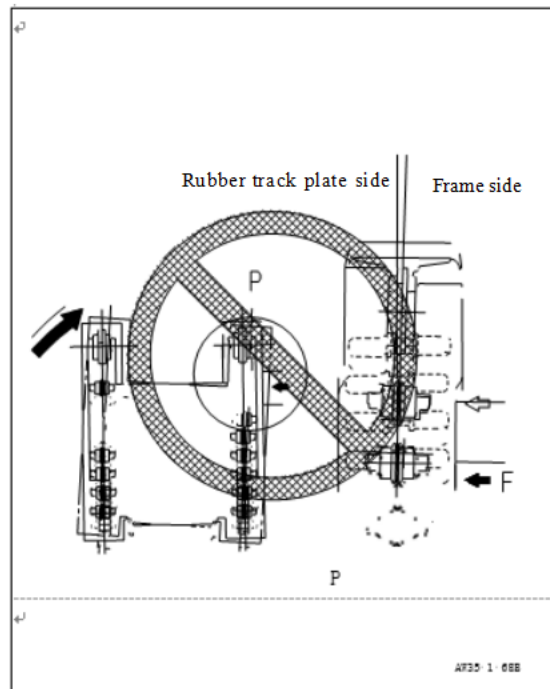

- If the machine travels reversely in this condition, the rubber track plate will fall off.

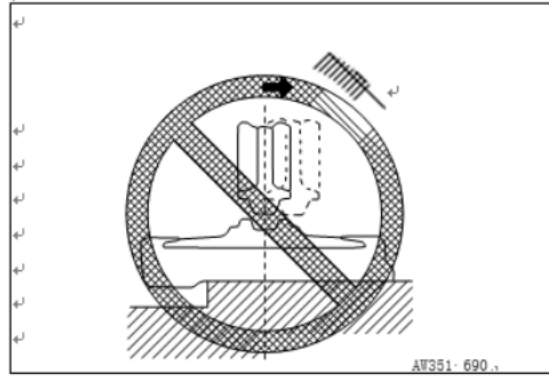

- If the machine turns in this condition, the rubber track plate will fall off.

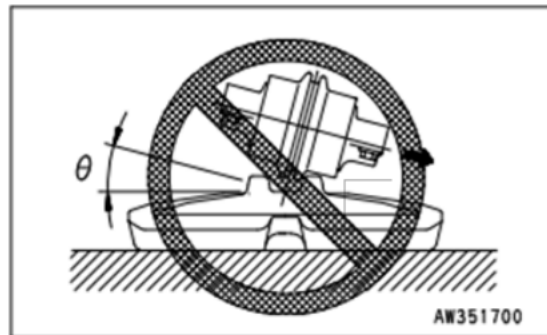

# Transportation

## 1. Transportation

When transporting, please observe the relevant laws for safe transportation.

### 1.1 Strictly adhere to road transportation laws

When transporting the machine, the transportation company to which you have entrusted the transportation shall confirm local regulations.

- When transporting this machine on a flatbed truck, etc., please study the width, height, length, weight, etc. of the machine. Transportation weight and dimensions vary depending on the type of track plate and the specifications of the working device.
- Please refer to the quality and size of the model shown by the manufacturer and choose the appropriate transportation method.
- The width, height, and mass (weight) limits of vehicles, as well as traffic laws and regulations, shall be investigated in advance on the route.

#### A **Warning** Confirm the movement of the operating lever

Before operation, be sure to pay attention to the safety of the surrounding area, operate each operating lever slowly, and confirm that the operation mode of the identification nameplate corresponds to the movement of the machine. In case of inconsistency, immediately replace with a consistent identification nameplate

For other precautions related to transportation, please refer to Chapter 1 "Operation Precautions".

## 2 Method of loading and unloading the machine

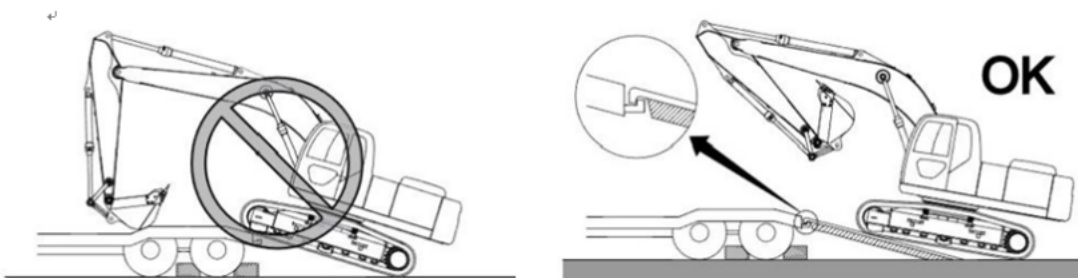

#### A **Warning** About loading and unloading

- Please load and unload on a flat and firm road surface whenever possible.
- Please use bridge plates, terraces, and platforms with sufficient width, length, slope, stiffness, and strength.
- To prevent the machine from sliding sideways on the bridge plate, please remove dirt, etc. from the track assembly. Please also remove any adhesion such as water, snow, ice, grease, and engine oil from the bridge plate.
- When loading or unloading, please set the engine speed as low, and set the driving Speed 1 and Speed 2 switch as Speed 1 (low).
- Loading and unloading with working device is very dangerous. Do not use it.
- Do not operate any lever other than the travel lever on the bridge plate.
- At the boundary between the machine and the bridge plate, the position of the center of gravity shifts violently. Therefore, it may be out of balance. Please drive slowly.

- Be sure to set the automatic speed regulation switch as "OFF". If it is run with the automatic speed control switch in the "ON" position, the engine speed may sometimes change drastically.
- Due to the danger of tipping over, never change your course of advancement on the bridge plate. Please return to the road surface or cargo platform, and then change the course of advancement.
- When the machine is going downhill or being loaded onto or unloaded from a flatbed truck, set the traveling Speed 1 (turtle) and Speed 2 (rabbit) toggle switches to low speed.

The automatic traveling Speed 1 (low speed) and Speed 2 (high speed) systems automatically change the traveling speed, so it may adversely affect the machine's control and sudden changes in the machine's control may cause a serious injury when the machine is traveling downhill or when it is being loaded onto or unloaded from a flatbed truck.

- Loading and unloading of the machine shall be completed under the guidance of the commander.

## 2.1 Loading

Please follow the steps below for implementation.

### When using a bridge plate

1. To prevent the flatbed truck from moving, please block the flatbed truck's tires with wheel wedges.

2. Please use a bridge plate for which adequate length, width, strength, and slope are ensured. The angle (A) between the bridge plate and the ground shall be 15° or less.

3. Start the engine and lower the lifting hydraulic locking lever to the "locked position".

4. Press the traveling speed switch on the switch box part and place it at traveling Speed 1 (low speed).

5. Before getting on the bridge plate, please confirm that the body is in a straight line with the bridge plate, lift up the dozer blade (when it is being installed), and then drive slowly.

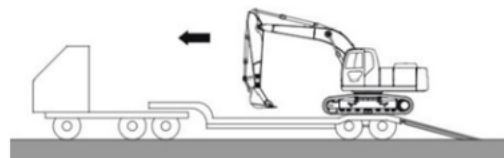
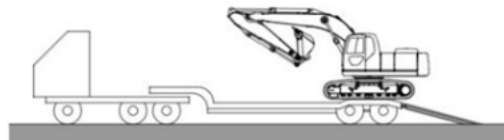
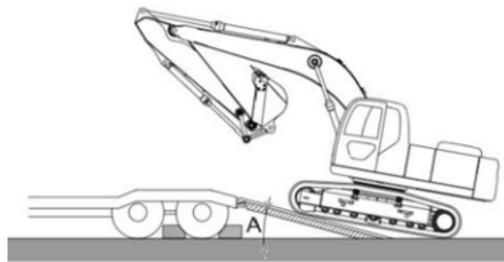

### A Attention

When this machine goes up (down) the bridge plate, as shown in the picture, fold the arm and the working device, and lift the boom to avoid interfering with the bridge plate and the base of the flatbed truck.

If the clearance to the bridge plate and the base of the flatbed truck is small, the machine will

suddenly tilt at the moment it crosses the bridge plate, and the small arm and the bucket will hit the cargo platform of the flatbed truck, the bridge plate, or the ground, and as a result, it will cause damage to the cylinders.

6. After reaching the specified position, slowly rotate the upper swivel body for 180°.

7. Please lower the working device slowly.

8. Place the lifting hydraulic locking lever in the locked position.

9. Please turn off the engine and remove the start key.

10. Please lock the guard board and doors in the locked position.

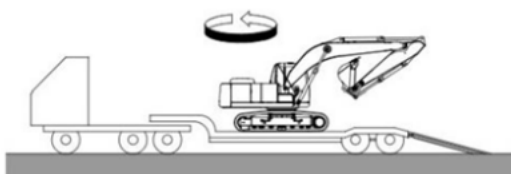

### **When loading by means of terrace or platform**

1. For the width of the platform, the width of the machine shall be considered. Please keep an adequate area. Please keep the angle (A) of the terrace or platform at 15° or less relative to the ground.

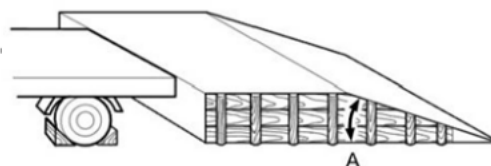

2. Please confirm that the platform is strong enough to withstand the weight of the machine.

3. Please align the height of the terrace or platform with the height of the flatbed truck's cargo platform.

4. Please Park the flatbed truck correctly in the specified position.

### **Loading of machines not installed with working devices**

#### **A Warning Rotation prohibition**

Do not rotate the machine when loading or unloading.

The machine may fall on the counterweight side.

- When loading a machine that is not equipped with a working device, please keep the counterweight block above the slope surface.

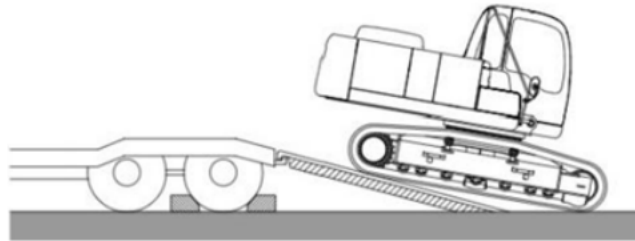

## 2.2 Fixing of the machine

### Additional instructions

- When transporting, please fold up the antenna of the radio. And remove mirrors as appropriate. Please keep the removed parts, etc., properly in the cab.
- To prevent damage to the bucket (working device) cylinder during transportation, prevent it from touching the ground by placing a square timber under the connecting rod of the bucket.
- Please observe all regulations and restrictions of the state and local self-government organization.

After loading in the specified position, please fix the vehicle according to the following instructions.

1. Please confirm that all guard boards and doors are locked.

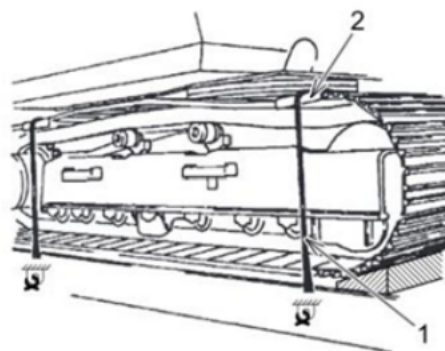

### Rubber tracks and track plates

Do not hang rubber tracks and track plates directly on steel ropes or chains (1). Place pads (2) (gaskets, etc.) on the left and right sides of the track support, and securely fix them to the cargo platform of the flatbed truck.

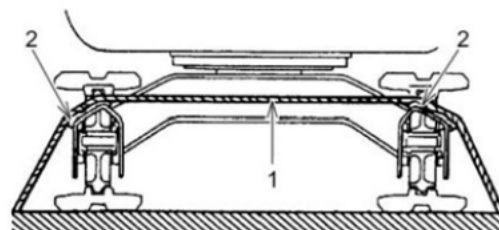

2. Please put wedges in front of and behind the tracks to ensure that the body will not be shifted back and forth and sway from side to side due to the vibration of the flatbed truck.

3. Securely fix the position shown in the picture using a steel rope or chain (1) with suitable strength.

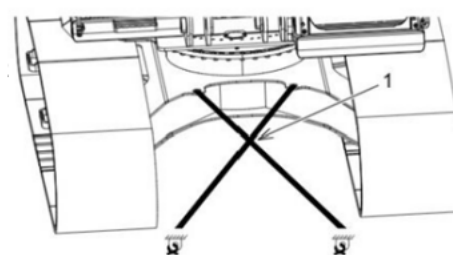

- Front and rear of the track

- Front and rear of the lower bracket
- Front of the arm

Use a pad (2) (gasket, etc.) to secure the fixing part of the track and arm.

In addition, individual parts and removed parts shall be securely fixed to the flatbed truck.

### 2.3 Unloading

Please follow the steps below for implementation.

1. To prevent the flatbed truck from moving, please block the flatbed truck's tires with wheel wedges.

2. Please use a bridge plate for which adequate length, width, strength, and slope are ensured. The angle (A) between the bridge plate and the ground shall be 15° or less.

3. Please remove the chain or steel rope fixing the machine.

4. Start the engine and lower the lifting hydraulic locking lever to the "locked position".

5. Press the traveling speed switch on the switch box part and place it at traveling Speed 1 (low speed).

6. Please raise the boom slowly.

7. Lift up the working device and lift up the dozer blade (when it is mounted) in a state where the arm is rolled under the boom, and move it slowly.

8. Please keep the machine level over the back end of the flatbed truck and stop it temporarily.

9. Please confirm that the bridge plate is kept parallel to the machine, and adjust the angle between the arm and boom to 80°~100°.

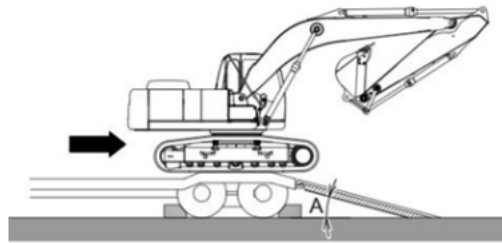

#### A Attention

When this machine goes up (down) the bridge plate, as shown in the picture, fold the arm and the working device, and lift the boom to avoid interfering with the bridge plate and the base of the flatbed truck.

If the clearance to the bridge plate and the base of the flatbed truck is small, the machine will suddenly tilt at the moment it crosses the bridge plate, and the small arm and the bucket will hit the cargo platform of the flatbed truck, the bridge plate, or the ground, and as a result, it will cause damage to the cylinders.

10. To make the bucket touch the ground in the event of an emergency, slowly move the

boom and arm, and keep the bucket close to the ground while slowly lowering the bridge plate until the boom and arm are fully lowered.

11. After lowering to the ground, please slowly turn the upper swivel body for 180° and keep it in a forward traveling position (The traveling reducer is located on the rear).

### 3. Main body lifting

#### A Warning About machine lifting

- Use wire ropes and other lifting devices that are not damaged or deteriorated and have sufficient strength for lifting.
- If the method of lifting is wrong and the wire rope is hung incorrectly, the machine will move when lifted, resulting in a fatal accident or damage to the machine.
- Do not apply sharp loads to the wire rope and appliances for lifting.
- When lifting the machine, please move away from its surrounding area. When lifting, unforeseen circumstances may occur.
- Do not stand under or around the machine during lifting.
- When lifting the machine by working together, please signal each other for operation.
- Do not perform lifting operation with the operator on the machine.
- When lifting, keep the machine level.

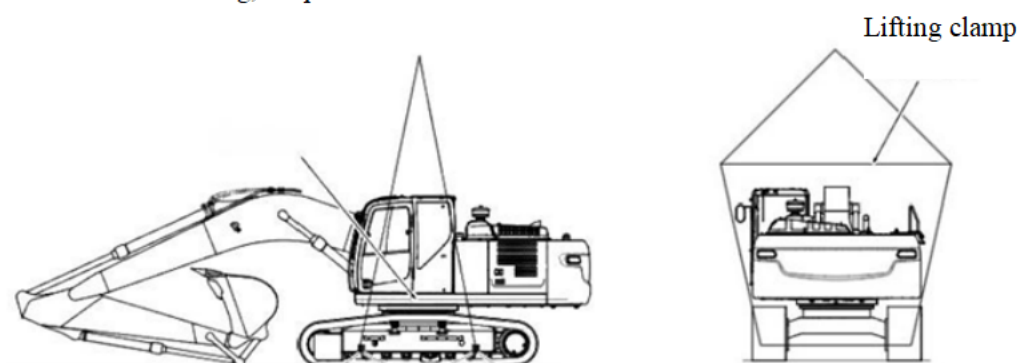

#### Additional instructions

- This lifting technique is recommended for machines of standard size.

For lifting operations, please verify the machine's weight and center of gravity, along with the strength of the wire ropes and lifting clamps, considering the type of working device and optional specifications. Kindly reach out to us or visit our sales store for assistance.

- Ensure that the wire ropes and lifting clamps are long enough to prevent them from touching the machine during the lifting process.
- If needed, protect the machine by covering the wire rope with a cloth or using a mat to prevent damage.

#### 3.1 Essentials for lifting

1. Please move the machine to a flat area.
2. For the working device, fully extend the arm cylinder and bucket cylinder, then lower the boom until it touches the ground.
3. Ensure that the cab remains aligned parallel to the direction of the tracks.

4. Place the lifting cutoff locking levers in the locked position, stop the engine and remove the start key.
5. Ensure the front window and window glass are closed, and lock the cab's door as well as the left and right side doors and the hood.
6. Thread the wire rope between the 1st and 2nd lower rollers on both the front and rear sides of the machine.
7. Adjust the lifting angle of the wire rope to between 20° and 30°, then proceed to lift.
8. After lifting off the ground, pause briefly and slowly lift once the machine has stabilized.

#### 4. Assembly and removal of mirrors

The mirrors are removed at the factory.

When installing or removing the mirror, refer to "Mirror Adjustment".

#### 5. Towing

##### A Warning Please read the Instructions for Use.

Please read the safety messages and indication in this instruction manual, and understand and follow them. Failure to follow this instruction manual and unintentional use of the machine may result in a serious injury, fatal accident, or severe damage to this machine.

Towing in the wrong way can cause serious fatal accidents. Note the following matters during towing operations. · When handling the wire rope by hand, be sure to wear leather gloves.

- The track frame can withstand a load equivalent to 100% of the machine's total weight.
- Ensure that the tow rope has sufficient strength to support the weight of the machine being towed.
- Avoid using ropes with a broken core (A), reduced diameter (B), or knots (C), as they may break.
- Avoid towing on an incline.
- Do not place yourself between the towing machine and the towed machine (or object) during towing.
- To protect the wire rope and track frame from damage, position pads at the corners of the track frame.
- Operate the machine slowly and avoid applying shock loads to the rope.
- Be sure to use a steel ring when connecting the rope for towing.

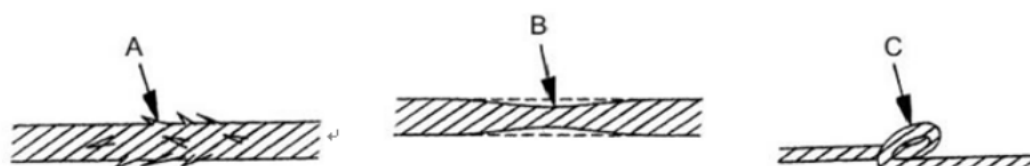

##### 5.1 Method for towing this machine

- When the machine cannot move on its own, attach a wire rope of appropriate strength to the designated point on the track frame as shown in the illustration, and use other machines for towing.

- Ensure the rope remains horizontal and aligned straight toward the drop frame, as illustrated.
- To prevent the machine from going out of control before releasing the brake when the travel motor is disengaged from traction, place barriers on both tracks.

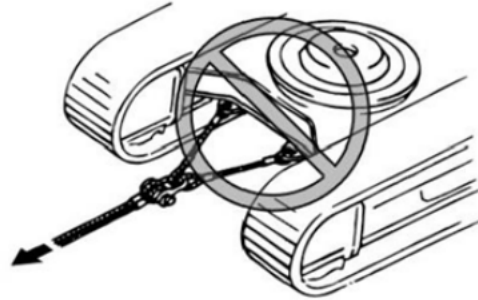
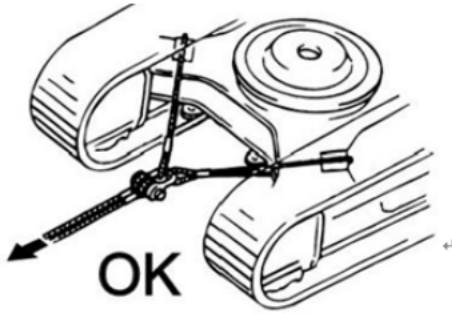

## Optional parts

### 1. About the use of machines equipped with breaker hammers

#### 1.1 Selection of breaker hammers

When installing a breaker hammer, select one that is suitable for body stability and working pressure.

In addition, observe the operating precautions specified by the breaker hammer manufacturer.

#### 1.2 Installation of breaker hammers

After installing the breaker hammer, make sure that the mounting parts are not loose and that there are no oil leaks from pipes or abnormal sounds before starting work.

After removing the breaker hammer, use a plug to keep the tube on the body side of the front end of the arm and the tube on the side of the breaker hammer to prevent dust and water from entering.

#### 1.3 Precautions during breaker hammer operation

##### Prohibition of prying operations

Avoid using a breaker hammer to pry rock or concrete. There is a risk of damage to the boom or arm, or to the breaker hammer.



##### Restriction to crushing operations only

Avoid breaking rock or concrete using a sharp fall breaker hammer or by tapping with a breaker hammer.

The impact of the knock may cause damage to the boom, arm, breaker hammer, or machine body.



##### Prohibition of moving broken objects

Avoid using a breaker hammer to move crushed objects or similar materials.

Particularly when rotational forces are employed to move the rock sideways, there is a risk of damaging the boom, arm, breaker hammer, or machine body.



### **Prohibition of operating at the cylinder stroke end**

While operating, maintain a margin at the end of the cylinder stroke.

Operating at the end of the cylinder stroke can generate significant stress on the boom, arm, or machine body, potentially causing damage.



### **Prohibition of operating the breaker hammer for more than 1 minute continuously**

If a spot remains unbroken after striking continuously for 1 minute or more, shift the striking position.

Continuous striking can cause an increase in oil temperature or lead to abnormal wear of the breaker hammer chisel cutter.

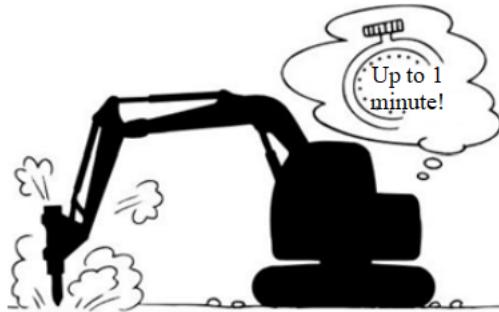

### **Prohibition of lifting**

Do not operate the breaker hammer under water. There is a risk that the breaker hammer may rust, and the sealing section could break, allowing rust, debris, and water to mix in and damage the hydraulic machinery of the machine body.



### **Prohibition of operation in water**

Do not operate the breaker hammer under water. There is a risk that the breaker hammer may rust, and the sealing section could break, allowing rust, debris, and water to mix in and damage the hydraulic machinery of the machine body.

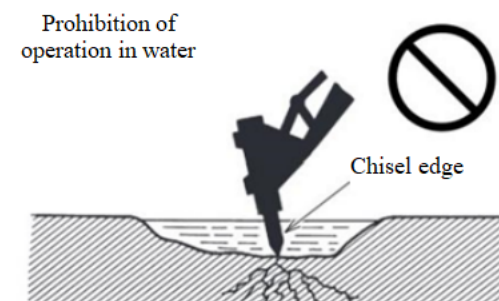

### **Suspension of operations if the hose shakes**

In the event of abnormal shaking of the hydraulic hose during breaker operation, cease operation immediately and promptly contact our distributor.

If ignored and usage continues, it may result in damage to the hydraulic machinery or piping.



### Prohibition of idling

Do not idle the breaker hammer. Idling may result in increased working oil temperatures or damage to the breaker hammer.



### Guidelines for lifting body operations

The body lift during breaker hammer operation should be maintained between 10 to 15 cm. Excessive lifting may lead to damage to the boom or arm.

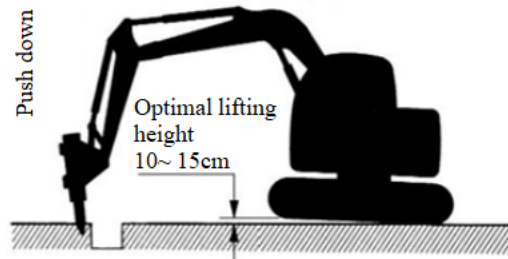

### Prohibition of side operations

Do not execute crushing operations sideways.

It can place heavy loads on the tracks, potentially causing bending of track palte or oil leakage from the track rollers.

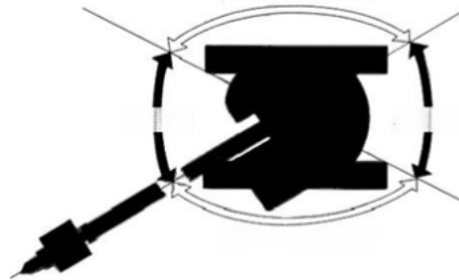

### Note the direction of the breaker hammer

The breaker hammer should be depressed in the same direction as the chisel cutter's shaft, ensuring that the chisel cutter maintains direct contact with the crushing surface.

Operating in an improper position can result in damage to the breaker hammer's sealing part due to the intrusion of debris or water, leading to hydraulic mechanical damage to the machine body.

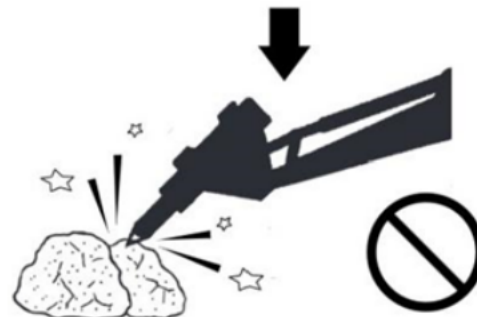

### Prohibition of horizontal or upward-facing operations

Avoid performing crushing operations horizontally or in an upward-facing direction.

This can impose a significant load on the boom, arm, and machine body, potentially causing damage.



### Note the chisel cutter colliding with the boom

When retracting the breaker hammer, there's a risk that the chisel cutter may strike the boom, so exercise caution during operation.



## 2. Regular check and maintenance of the breaker hammer

### 2.1 List of regular check and maintenance of the breaker hammer

When using a hydraulic breaker hammer, the machine operates under more severe conditions compared to digging operations, which accelerates the aging and contamination of the working oil.

Neglecting maintenance can lead to failures in the machine body, hydraulic breaker hammer, and hydraulic equipment. To prolong the lifespan of your hydraulic equipment, ensure that you replace the working oil and filter element at the recommended intervals listed below.

Item	Check and maintenance parts	Replacement interval (hours)		
		First	Second	Periodicity
Working oil	Working oil tank			1000
Oil return filter element kits (P/No.YR52V01004R310)	Working oil tank	1000	2000	1000

### 2.2 Strengthen of working device

When a suitable breaker hammer is installed and the machine is operated correctly, the factory-standard arm generally does not require additional reinforcement. However, if it will be used in a special manner, please consult our sales store.

## 3. Attention points proposed by breaker hammer manufacturers

When installing a breaker hammer, ensure you are familiar with the precautions for its use and the specific points to note for each breaker hammer model.

Installing an accumulator may be required.

Verify the details with our sales store before proceeding.